



**Applications:**

1. Making corner connections with a weld-on profile, ~50° interlock flexibility.
2. Suitable for circular piling.
3. Constructing pipe + Larssen (U-piles and Z-piles) sheet pile combined walls.

**Typical Properties:**

Steel grade: ASTM A572 Grade 50 (S 355 GP)  
 Weight per linear foot: 5.64 pounds (8.4 kg per meter)

**CAD-Service**

Downloads of data sheets and CAD files are available at [www.pilepro.com/c90](http://www.pilepro.com/c90)

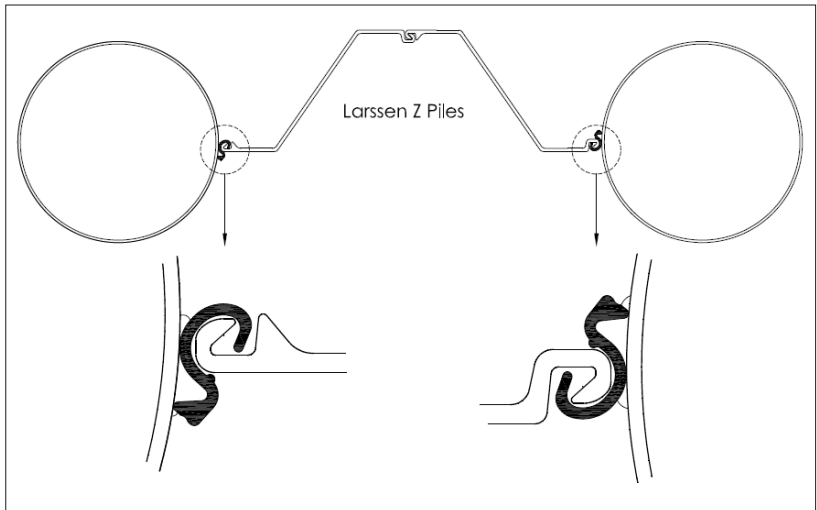
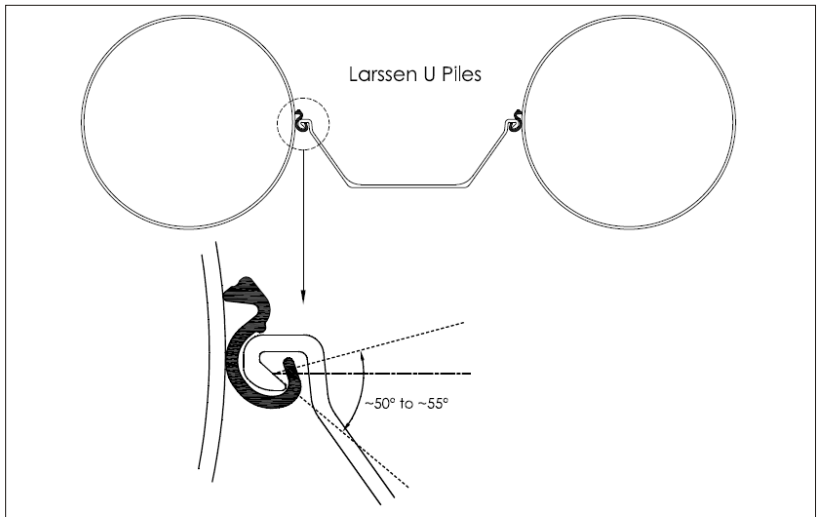
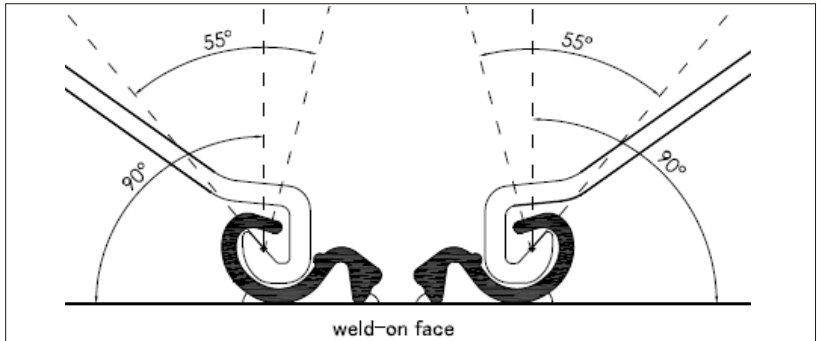
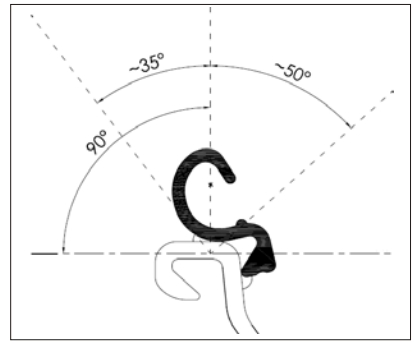
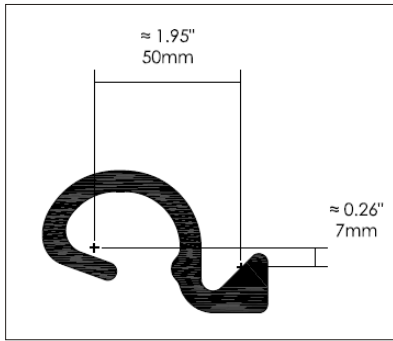

**Please note:**

1. Swing or rotation stated are typical but can vary by 10° or more due to rolling tolerances found in sheet pile interlocks.
2. PilePro® connectors are protected by patents.