



Steel Foundation Systems

Technical Product Manual

2012 Edition

Your True Project Partner

Unmatched Product Range

As the premier leader of steel pile systems and solutions, Skyline Steel's blend of products is unrivaled. From hot and cold rolled sheet pile to H-piles, pipe piles to threaded bar systems, only Skyline Steel offers the product range to meet the design and construction demands of the Americas.

Material Availability

With strategic stocking locations throughout the Americas, Skyline Steel has established a material delivery network that is primed for immediate response. Our facilities offer barge, rail and truck transportation options for cost effective and on-time delivery.

Manufacturing Capabilities

Skyline Steel owns and operates pipe, sheet pile, threaded bar and pile accessory facilities. Production is supplemented with full fabrication capabilities to provide a single source for all your foundation needs.

Innovative Applications and Engineering Expertise

Skyline Steel has sales offices throughout the Americas staffed with experienced sales professionals to help meet your material needs. In addition, only Skyline Steel offers exclusive engineering support in project design and construction.



Table of Contents

- Conversion Table** 2
- Steel Sheet Pile** 3
 - AZ Hot Rolled Steel Sheet Pile 5
 - AS Hot Rolled Steel Sheet Pile 7
 - PZ/PS Hot Rolled Steel Sheet Pile 9
 - SKZ Cold Formed Steel Sheet Pile 11
 - SCZ Cold Formed Steel Sheet Pile 13
 - SKL/SKS Cold Formed Steel Sheet Pile 15
- Combined Wall Systems** 17
 - Pipe-Z Combined Wall Systems 19
 - Pipe-Pipe Combined Wall Systems 27
 - HZM Steel Wall Systems 31
- Steel H-Pile** 57
- Pipe** 61
 - Spiralweld Pipe 63
 - Rolled and Welded Pipe 65
- Pile Accessories** 67
- Threaded Bar and Accessories** 71
- Micropile** 77
- Structural Sections** 81

Conversion Table

	Imperial to Metric		Metric to Imperial			
Dimensions	1 in	=	2.5400 cm	1 cm	=	0.3937 in
	1 ft	=	0.3048 m	1 m	=	3.2808 ft
	1 in ²	=	6.4516 cm ²	1 cm ²	=	0.1550 in ²
	1 ft ²	=	0.0929 m ²	1 m ²	=	10.7639 ft ²
	1 in ³	=	16.3870 cm ³	1 cm ³	=	0.0610 in ³
	1 ft ³	=	0.0283 m ³	1 m ³	=	35.3149 ft ³
	1 in ² /ft.	=	21.166 cm ² /m	1 cm ² /m	=	0.0472 in ² /ft
Mass, Force, Pressure	1 lb	=	4.4497 N	1 N	=	0.2247 lb
	1 lb/in	=	0.1752 N/mm	1 N/mm	=	5.7082 lb/in
	1 lb/ft	=	14.5989 N/m	1 N/m	=	0.0685 lb/ft
	1 lb/in ²	=	0.6897 N/cm ²	1 N/cm ²	=	1.4499 lb/in ²
	1 lb/ft ²	=	47.8968 N/m ²	1 N/m ²	=	0.0209 lb/ft ²
	1 lb/in ³	=	0.2715 N/cm ³	1 N/cm ³	=	3.6827 lb/in ³
	1 lb/ft ³	=	157.1420 N/m ³	1 N/m ³	=	0.0064 lb/ft ³
	1 lb	=	0.4536 kg	1 kg	=	2.2046 lbs
	1 lb/ft	=	1.4882 kg/m	1 kg/m	=	0.6720 lb/ft
	1 lb/ft ²	=	4.8824 kg/m ²	1 kg/m ²	=	0.2048 lb/ft ²
	1 US Ton	=	0.9072 Metric Tons	1 Metric Ton	=	1.1023 US Tons
Moment of Inertia	1 in ⁴	=	41.6228 cm ⁴	1 cm ⁴	=	0.0240 in ⁴
	1 in ⁴ /ft	=	136.5582 cm ⁴ /m	1 cm ⁴ /m	=	0.0073 in ⁴ /ft
Section Modulus	1 in ³	=	16.3870 cm ³	1 cm ³	=	0.0610 in ³
	1 in ³ /ft	=	53.7631 cm ³ /m	1 cm ³ /m	=	0.0186 in ³ /ft
Moment	1 lb.ft	=	1.3563 Nm	1 Nm	=	0.7373 lb.ft
	1 lb.in/ft	=	0.3708 Nm/m	1 Nm/m	=	2.6968 lb.in/ft
	1 lb.ft/ft	=	4.4497 Nm/m	1 Nm/m	=	0.2247 lb.ft/ft

Steel Sheet Pile

Recycled Content

Hot Rolled:	100%
Cold Form:	70%
Recyclable:	100%

Skyline Steel supplies a wide variety of sheet pile from leading manufacturers. The company is supported by ArcelorMittal, its parent and an undisputed leader in sheet pile research and manufacturing. ArcelorMittal manufactures the hot-rolled AZ, AS, and HZM product lines in Luxembourg. Skyline Steel's robust infrastructure also includes its own cold form sheet pile mill in Belpre, Ohio, and Nucor-Yamato (Nucor), a long-time strategic partner specializing in the fabrication of hot-rolled PZ and PS products in Armorel, Arkansas.

Hot Rolled and Cold Formed Sheet Pile

Hot rolled and cold formed are two primary methods of manufacturing sheet pile. While there are key differences between these two methods, the most important distinction is the interlock. Since hot rolled sheet piles are produced from steel at high temperatures, the interlock tends to be tighter than its cold formed counterpart. Normally, looser interlocks are not recommended in extremely hard driving conditions or for walls requiring low permeability. Hot rolled sheet piles are generally larger and have a broader range of strengths than cold form sheet piles, but there is a large overlap between the two, especially in the most common sizes.

Applications of Sheet Pile

Around the world, sheet piles are utilized for various applications. Z-pile, named after its shape, is commonly used for cofferdams, levee strengthening, retaining structures, breakwaters, and bulkheads. In addition to these traditional applications, steel sheet piles are also used for bridge abutments, environmental barrier walls, underground parking garages, and depressed roads and railways. Sheet piles can also serve as permanent structural members in all of the applications listed above.

Sheet pile designs are based on the bending properties, section modulus, and moment of inertia. Durability and drivability of each section is also taken into consideration.

Flat sheet piles (straight web sheets) are used in the construction of cellular structures. Cellular cofferdams are utilized to dewater large areas during the construction of locks and dams and are also employed as permanent walls when loads are exceptionally high or there is little or no soil for embedment. Since the cells are gravity structures, large embedment is generally not necessary. The tension is resisted by the interlock. Unlike Z-pile or combination walls, interlock strength is the main design consideration for cellular cofferdams. The weight of the cell and the resistance of the flat sheet interlocks provide the stability of the structure.

Handling Holes

Handling holes are standard for all sheet pile sections. They are located in the centerline of each section.

Y = 9" (228.6 mm)

Ø = 2"-5" (50.8 mm - 127.0 mm)

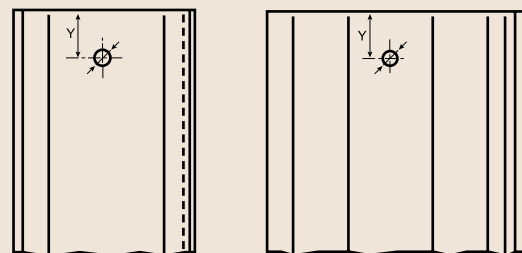

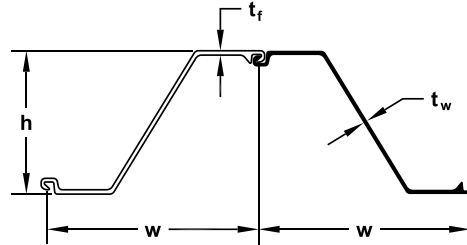

SECTION	Width (w) in (mm)	Height (h) in (mm)	THICKNESS		Cross Sectional Area in ² /ft (cm ² /m)	WEIGHT		SECTION MODULUS		Moment of Inertia in ⁴ /ft (cm ⁴ /m)	COATING AREA	
			Flange (t _f) in (mm)	Web (t _w) in (mm)		Pile lb/ft (kg/m)	Wall lb/ft ² (kg/m ²)	Elastic in ³ /ft (cm ³ /m)	Plastic in ³ /ft (cm ³ /m)		Both Sides ft ² /ft of single (m ² /m)	Wall Surface ft ² /ft ² (m ² /m ²)
AZ 12-770	30.31 770	13.52 343.5	0.335 8.50	0.335 8.50	5.67 120.1	48.78 72.60	19.31 94.30	23.2 1245	27.5 1480	156.9 21430	6.10 1.86	1.20 1.20
AZ 13-770	30.31 770	13.54 344.0	0.354 9.00	0.354 9.00	5.94 125.8	51.14 76.10	20.24 98.80	24.2 1300	28.8 1546	163.7 22360	6.10 1.86	1.20 1.20
AZ 14-770	30.31 770	13.56 344.5	0.375 9.50	0.375 9.50	6.21 131.5	53.42 79.50	21.14 103.20	25.2 1355	30.0 1611	170.6 23300	6.10 1.86	1.20 1.20
AZ 17	24.80 630	14.92 379.0	0.335 8.50	0.335 8.50	6.53 138.3	45.96 68.40	22.24 108.60	31.0 1665	36.2 1944	231.3 31580	5.64 1.72	1.35 1.35
AZ 18	24.80 630	14.96 380.0	0.375 9.50	0.375 9.50	7.11 150.4	49.99 74.40	24.19 118.10	33.5 1800	39.1 2104	250.4 34200	5.64 1.72	1.35 1.35
AZ 19	24.80 630	15.00 381.0	0.413 10.50	0.413 10.50	7.74 163.8	54.43 81.00	26.34 128.60	36.1 1940	42.3 2275	270.8 36980	5.64 1.72	1.35 1.35
AZ 17-700	27.56 700	16.52 419.5	0.335 8.50	0.335 8.50	6.28 133.0	49.12 73.10	21.38 104.40	32.2 1730	37.7 2027	265.3 36230	6.10 1.86	1.33 1.33
AZ 18-700	27.56 700	16.54 420.0	0.354 9.00	0.354 9.00	6.58 139.2	51.41 76.50	22.39 109.30	33.5 1800	39.4 2116	276.8 37800	6.10 1.86	1.33 1.33
AZ 19-700	27.56 700	16.56 420.5	0.375 9.50	0.375 9.50	6.88 145.6	53.76 80.00	23.41 114.30	34.8 1870	41.0 2206	288.4 39380	6.10 1.86	1.33 1.33
AZ 25	24.80 630	16.77 426.0	0.472 12.00	0.441 11.20	8.74 185.0	61.49 91.50	29.74 145.20	45.7 2455	53.4 2873	382.6 52250	5.91 1.80	1.41 1.41
AZ 26	24.80 630	16.81 427.0	0.512 13.00	0.480 12.20	9.35 198.0	65.72 97.80	31.79 155.20	48.4 2600	56.9 3059	406.5 55510	5.91 1.80	1.41 1.41
AZ 28	24.80 630	16.85 428.0	0.551 14.00	0.520 13.20	9.97 211.1	70.15 104.40	33.94 165.70	51.2 2755	60.5 3252	431.6 58940	5.91 1.80	1.41 1.41
AZ 24-700	27.56 700	18.07 459.0	0.441 11.20	0.441 11.20	8.23 174.1	64.30 95.70	28.00 136.70	45.2 2430	53.5 2867	408.8 55820	6.33 1.93	1.38 1.38
AZ 26-700	27.56 700	18.11 460.0	0.480 12.20	0.480 12.20	8.84 187.2	69.12 102.90	30.10 146.90	48.4 2600	57.1 3070	437.3 59720	6.33 1.93	1.38 1.38
AZ 28-700	27.56 700	18.15 461.0	0.520 13.20	0.520 13.20	9.46 200.2	73.93 110.00	32.19 157.20	51.3 2760	60.9 3273	465.9 63620	6.33 1.93	1.38 1.38
AZ 36-700N	27.56 700	19.65 499.0	0.591 15.00	0.441 11.20	10.20 216.0	79.70 118.60	34.61 169.00	66.8 3590	76.5 4110	656.2 89610	6.76 2.06	1.46 1.47
AZ 38-700N	27.56 700	19.69 500.0	0.630 16.00	0.480 12.20	10.87 230.0	84.94 126.40	37.07 181.00	70.6 3795	81.1 4360	694.5 94840	6.76 2.06	1.46 1.47
AZ 40-700N	27.56 700	19.72 501.0	0.669 17.00	0.520 13.20	11.53 244.0	90.18 134.20	39.32 192.00	74.3 3995	85.7 4605	732.9 100080	6.76 2.06	1.46 1.46
AZ 42-700N	27.56 700	19.65 499.0	0.709 18.00	0.551 14.00	12.22 259.0	95.49 142.1	41.57 203.00	78.2 4205	90.3 4855	766.0 104930	6.76 2.06	1.47 1.47
AZ 44-700N	27.56 700	19.69 500.0	0.748 19.00	0.591 15.00	12.89 273.0	100.73 149.9	43.83 214.00	81.9 4405	94.9 5105	804.1 110150	6.76 2.06	1.47 1.47
AZ 46-700N	27.56 700	19.72 501.0	0.787 20.00	0.630 16.00	13.55 287.0	105.97 157.7	46.08 225.00	85.7 4605	99.5 5350	842.2 115370	6.76 2.06	1.47 1.47
AZ 46	22.83 580	18.94 481.0	0.709 18.00	0.551 14.00	13.76 291.2	89.10 132.60	46.82 228.60	85.5 4595	98.5 5295	808.8 110450	6.23 1.90	1.63 1.63
AZ 48	22.83 580	18.98 482.0	0.748 19.00	0.591 15.00	14.48 306.5	93.81 139.60	49.28 240.60	89.3 4800	103.3 5553	847.1 115670	6.23 1.90	1.63 1.63
AZ 50	22.83 580	19.02 483.0	0.787 20.00	0.630 16.00	15.22 322.2	98.58 146.70	51.80 252.9	93.3 5015	108.2 5816	886.5 121060	6.23 1.90	1.63 1.63

Available Steel Grades											
AMERICAN			CANADIAN			EUROPEAN			AMLoCor**		
ASTM	YIELD STRENGTH		CSA G40.21	YIELD STRENGTH		EN 10248	YIELD STRENGTH		YIELD STRENGTH		
	(ksi)	(MPa)		(ksi)	(MPa)		(ksi)	(MPa)	(ksi)	(MPa)	
A 328	39	270	Grade 260 W	38	260	S 240 GP	35	240	Blue 320	46	320
A 572 Gr. 42	42	290	Grade 300 W	43	297	S 270 GP	39	270	Blue 355	51	355
A 572 Gr. 50	50	345	Grade 350 W	51	355	S 320 GP	46	315	Blue 390	57	390
A 572 Gr. 55	55	380	Grade 400 W	58	400	S 355 GP	51	355			
A 572 Gr. 60	60	415				S 390 GP	57	390			
A 572 Gr. 65	65	450				S 430 GP	62	430			
A 690	50	345				S 460 AP	67	460			
A 690*	57	390									

*Not available for AZ 36-700N and larger. ** Corrosion resistant steel, check for availability

Corner Piles

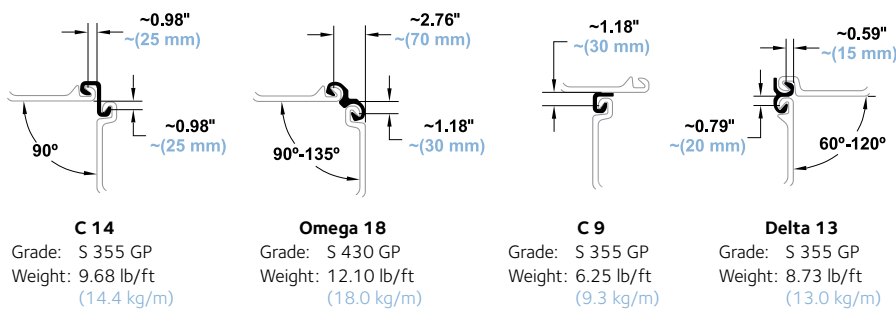

Delivery Conditions & Tolerances

	ASTM A 6	EN 10248
Mass	± 2.5%	± 5%
Length	+ 5 inches - 0 inches	± 200 mm
Height		± 7 mm
Thickness		≤ 8.5 mm ± 0.5 mm > 8.5 mm ± 6%
Width		± 2%
Double Pile Width		± 3%
Straightness		0.2% of the length
Ends out of Square		2% of the width

Maximum Rolled Lengths*

AZ	101.7 feet	(31.0 m)
C 9	59.1 feet	(18.0 m)
C 14	59.1 feet	(18.0 m)
Delta 13	59.1 feet	(18.0 m)
Omega 18	52.0 feet	(16.0 m)

* Longer lengths may be possible upon request.

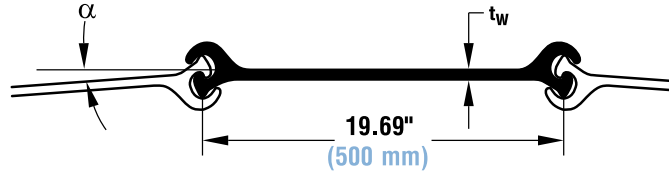

SECTION	Width* (w) in (mm)	Web (t _w) in (mm)	Maximum Interlock Strength k/in (kN/m)	Allowable Interlock Rotation** (α) Degrees	Cross Sectional Area in ² /ft (cm ² /m)	WEIGHT		Elastic Section Modulus in ³ /sheet (cm ³ /sheet)	Moment of Inertia in ⁴ /sheet (cm ⁴ /sheet)	COATING AREA	
						Pile lb/ft (kg/m)	Wall lb/ft ² (kg/m ²)			Both Sides ft ² /ft of single (m ² /m)	Wall Surface ft ² /ft ² of wall (m ² /m ²)
AS 500 9.5	19.69 500	0.375 9.5	17.1 3000	4.5	7.71 163.2	43.01 64.0	26.22 128	2.3 37	4.1 170	3.77 1.15	1.15 1.15
AS 500 11.0	19.69 500	0.433 11.0	20.0 3500	4.5	8.50 180.0	47.46 70.6	28.88 141	3.0 49	4.5 186	3.77 1.15	1.15 1.15
AS 500 12.0	19.69 500	0.472 12.0	28.5 5000	4.5	8.94 189.2	49.93 74.3	30.52 149	3.1 51	4.7 196	3.77 1.15	1.15 1.15
AS 500 12.5	19.69 500	0.492 12.5	31.4 5500	4.5	9.19 194.5	51.27 76.3	31.34 153	3.1 51	4.8 201	3.77 1.15	1.15 1.15
AS 500 12.7	19.69 500	0.500 12.7	31.4 5500	4.5	9.28 196.4	51.81 77.1	31.54 154	3.2 52	4.9 204	3.77 1.15	1.15 1.15

* Use 503 mm for template construction and layout drawings.

** The mill guarantees 4.5 degrees of interlock rotation for piles < 20 m. in length. For piles > 20 m. in length, the guaranteed rotation is 4 degrees.

Pre-bent piles are available to achieve a tighter radius in the cells and arcs.

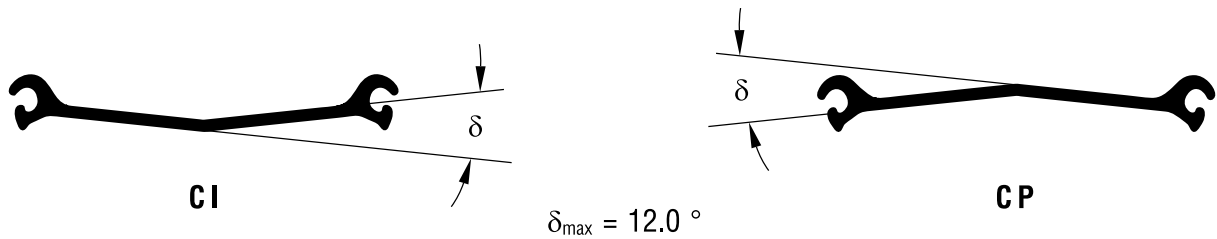

Available Steel Grades								
AMERICAN			CANADIAN			EUROPEAN		
ASTM	YIELD STRENGTH		CSA G40.21	YIELD STRENGTH		EN 10248	YIELD STRENGTH	
	(ksi)	(MPa)		(ksi)	(MPa)		(ksi)	(MPa)
A 328	39	270	Grade 260 W	38	260	S 240 GP	35	240
A 572 Grade 42	42	290	Grade 300 W	44	300	S 270 GP	39	270
A 572 Grade 50	50	345	Grade 350 W	50	345	S 320 GP	46	315
A 572 Grade 55	55	380	Grade 400 W	58	400	S 355 GP	51	355
A 572 Grade 60	60	415				S 390 GP	57	390
A 572 Grade 65	65	450				S 430 GP	62	430
A 690	50	345						
A 690	57	390						

Junction Piles

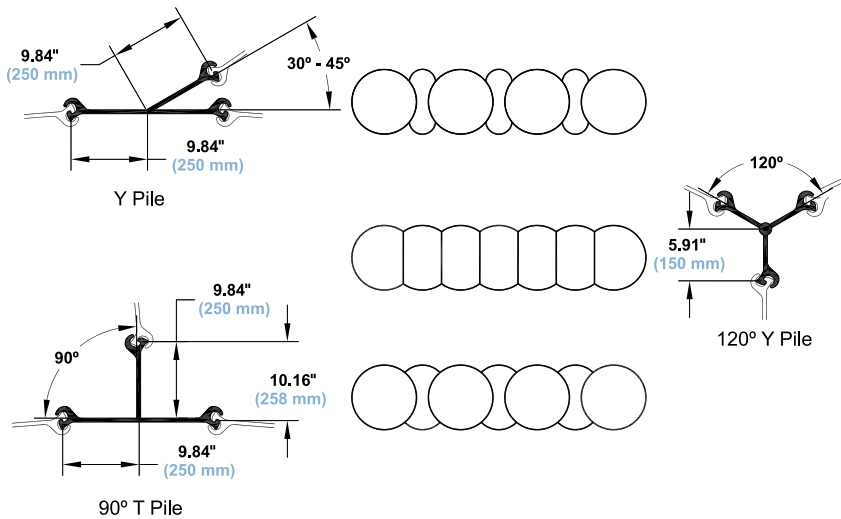

Delivery Conditions & Tolerances

	ASTM A 6	EN 10248
Mass	± 2.5%	± 5%
Length	+ 5 inches - 0 inches	± 200 mm
Height		± 5 mm
Thickness		± 6%
Width		± 2%
Straightness		0.2% of the length
Ends out of Square		2% of the width

Maximum Rolled Lengths*

AS	101.7 feet	(31.0 m)
----	------------	----------

* Longer lengths may be possible upon request.

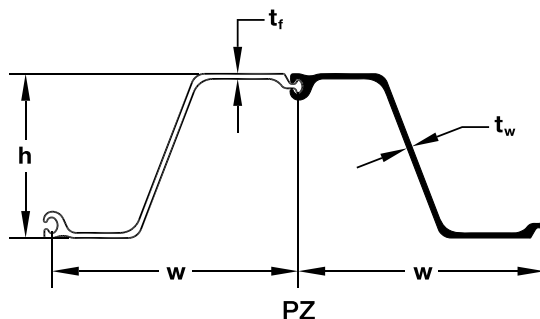

SECTION	Width (w) in (mm)	Height (h) in (mm)	THICKNESS		Cross Sectional Area in ² /ft (cm ² /m)	WEIGHT		SECTION MODULUS		Moment of Inertia in ⁴ /ft (cm ⁴ /m)	COATING AREA	
			Flange (t _f) in (mm)	Wall (t _w) in (mm)		Pile lb/ft (kg/m)	Wall lb/ft ² (kg/m ²)	Elastic in ³ /ft (cm ³ /m)	Plastic in ³ /ft (cm ³ /m)		Both Sides ft ² /ft of single (m ² /m)	Wall Surface ft ² /ft ² of wall (m ² /m ²)
PZ 22	22.0 559	9.0 229	0.375 9.50	0.375 9.50	6.47 136.9	40.3 60.0	22.0 107.4	18.1 973	21.79 1171.4	84.38 11500	4.48 1.37	1.22 1.22
PZ 27	18.0 457	12.0 305	0.375 9.50	0.375 9.50	7.94 168.1	40.5 60.3	27.0 131.8	30.2 1620	36.49 1961.9	184.20 25200	4.48 1.37	1.49 1.49
PZ 35	22.6 575	14.9 378	0.600 15.21	0.500 12.67	10.29 217.8	66.0 98.2	35.0 170.9	48.5 2608	57.17 3073.5	361.22 49300	5.37 1.64	1.42 1.42
PZ 40	19.7 500	16.1 409	0.600 15.21	0.500 12.67	11.77 249.1	65.6 97.6	40.0 195.3	60.7 3263	71.92 3866.7	490.85 67000	5.37 1.64	1.64 1.64

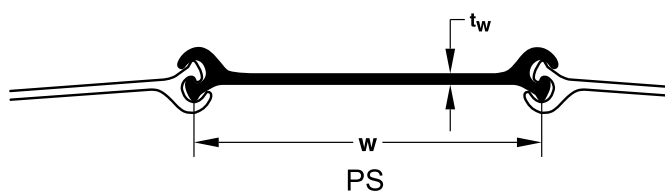

SECTION	Width (w) in (mm)	Web (t _w) in (mm)	Maximum Interlock Strength k/in (kN/m)	Minimum Cell Diameter* ft (m)	Cross Sectional Area in ² /ft (cm ² /m)	WEIGHT		Elastic Section Modulus in ³ /sheet (cm ³ /sheet)	Moment of Inertia in ⁴ /sheet (cm ⁴ /sheet)	COATING AREA	
						Pile lb/ft (kg/m)	Wall lb/ft ² (kg/m ²)			Both Sides ft ² /ft of single (m ² /m)	Wall Surface ft ² /ft ² of wall (m ² /m ²)
PS 27.5	19.69 500	0.4 10.2	24 4800	30 9.14	8.09 171.2	45.1 67.1	27.5 134.3	3.3 54	5.3 221	3.65 1.11	1.11 1.11
PS 31	19.69 500	0.5 12.7	24 4800	30 9.14	9.12 193.0	50.9 75.7	31.0 151.4	3.3 54	5.3 221	3.65 1.11	1.11 1.11

* Minimum cell diameter cannot be guaranteed for piles over 65 feet (19.81 m) in length, or if piles are spliced. 58 Piles are needed to make a 30 foot diameter cell.

PZ/PS

PZ/PS Hot Rolled Steel Sheet Pile

Available Steel Grades							
PZ				PS			
ASTM	YIELD STRENGTH		ASTM	YIELD STRENGTH		INTERLOCK STRENGTH	
	(ksi)	(MPa)		(ksi)	(MPa)	(k/in)	(kN/m)
A 328	39	270	A 328	39	270	16	2800
A 572 Grade 50	50	345	A 572 Grade 50	50	345	20	3500
A 572 Grade 60	60	415	A 572 Grade 60	60	415	24	4200
A 572 Grade 65	65	450	A 572 Grade 65	65	450	24	4200
A 588	50	345	A 588	50	345	20	3500
A 690	50	345	A 690	50	345	20	3500

Corner and Junction Piles

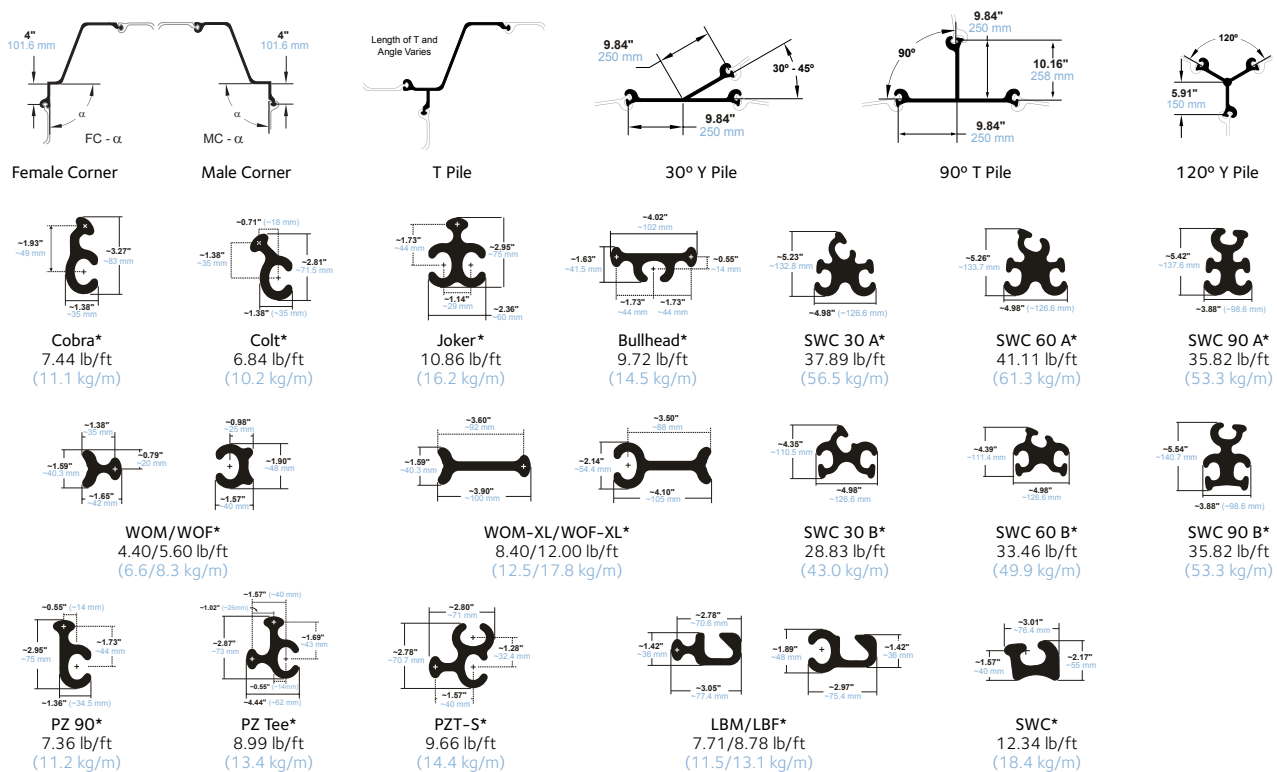

Delivery Conditions & Tolerances

ASTM A 6

Mass	± 2.5%
Length	+ 5 inches - 0 inches

Maximum Rolled Lengths[†]

PZ	85 feet for singles, 70 feet for pairs	(25.9 m, 21.3 m)
PS	65 feet	(19.8 m)

[†] Longer lengths may be possible upon request.

* Covered by one or more patents owned by PilePro, LLC (www.pilepro.com)

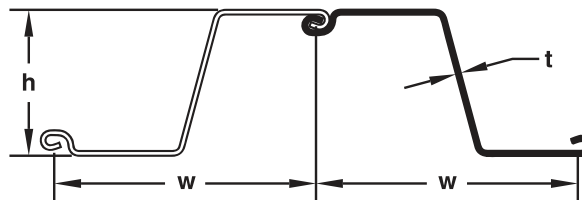

SECTION	Width (w) in (mm)	Height (h) in (mm)	Thickness (t) in (mm)	Cross Sectional Area in ² /ft (cm ² /m)	WEIGHT		SECTION MODULUS		Moment of Inertia in ⁴ /ft (cm ⁴ /m)	COATING AREA	
					Pile lb/ft (kg/m)	Wall lb/ft ² (kg/m ²)	Elastic in ³ /ft (cm ³ /m)	Plastic in ³ /ft (cm ³ /m)		Both Sides ft ² /ft (m ² /m)	Coating Area ft ² /ft ² (m ² /m ²)
SKZ 20	28.50 723.9	16.00 406.4	0.315 8.0	6.00 136.20	48.24 71.79	20.31 99.17	31.69 1704	36.66 1970.97	253.51 34618	7.60 2.32	1.60 1.60
SKZ 22	28.50 723.9	16.00 406.4	0.335 8.5	6.30 145.40	51.30 76.34	21.60 105.46	33.43 1797	38.94 2093.55	267.40 36515	7.60 2.32	1.60 1.60
SKZ 23	28.50 723.9	16.00 406.4	0.354 9.0	6.70 162.50	54.20 80.66	22.82 111.42	35.61 1915	41.12 2210.75	284.90 38905	7.60 2.32	1.60 1.60
SKZ 24	28.50 723.9	16.00 406.4	0.375 9.5	7.10 179.50	57.43 85.47	24.18 118.06	37.73 2028	43.52 2339.78	301.80 41213	7.60 2.32	1.60 1.60
SKZ 25	28.50 723.9	16.00 406.4	0.399 10.1	7.60 188.00	61.10 90.93	25.73 125.61	40.14 2158	46.24 2486.02	321.12 43851	7.60 2.32	1.60 1.60
SKZ 31	28.50 723.9	18.00 457.2	0.450 11.4	9.07 192.04	73.82 109.85	31.08 151.75	51.56 2772	60.51 3253.29	464.05 63369	8.06 2.46	1.70 1.70
SKZ 33	28.50 723.9	18.00 457.2	0.475 12.1	9.40 198.97	77.64 115.54	32.69 159.61	54.89 2951	63.57 3417.68	494.03 67462	8.06 2.46	1.70 1.70
SKZ 34	28.50 723.9	18.00 457.2	0.500 12.7	9.89 209.25	81.42 121.17	34.28 167.38	57.62 3098	66.86 3594.60	518.62 70821	8.06 2.46	1.70 1.70
SKZ 36	28.50 723.9	18.00 457.2	0.535 13.6	10.78 228.10	86.81 129.19	36.55 178.46	60.71 3264	71.58 3848.17	546.43 74619	8.06 2.46	1.70 1.70
SKZ 38	28.50 723.9	18.00 457.2	0.550 14.0	11.07 234.42	88.95 132.37	37.45 182.85	62.32 3350	73.52 3952.44	560.85 76588	8.06 2.46	1.70 1.70

Interlock Compatibility

	SCZ 14	SCZ 16	SCZ 17	SCZ 18	SCZ 19	SCZ 21	SCZ 22	SCZ 23	SCZ 25	SCZ 26	SCZ 29	SCZ 30	SKZ 20	SKZ 22	SKZ 23	SKZ 24	SKZ 25	SKZ 31	SKZ 33	SKZ 34	SKZ 36	SKZ 38
SCZ 14	●	●	●	●	●	●	●	●	●	●	●	●	●	●	●	●	●	○	○	○	○	○
SCZ 16	●	●	●	●	●	●	●	●	●	●	●	●	●	●	●	●	●	○	○	○	○	○
SCZ 17	●	●	●	●	●	●	●	●	●	●	●	●	●	●	●	●	●	○	○	○	○	○
SCZ 18	●	●	●	●	●	●	●	●	●	●	●	●	●	●	●	●	●	○	○	○	○	○
SCZ 19	●	●	●	●	●	●	●	●	●	●	●	●	●	●	●	●	●	○	○	○	○	○
SCZ 21	●	●	●	●	●	●	●	●	●	●	●	●	●	●	●	●	●	○	○	○	○	○
SCZ 22	●	●	●	●	●	●	●	●	●	●	●	●	●	●	●	●	●	○	○	○	○	○
SCZ 23	●	●	●	●	●	●	●	●	●	●	●	●	●	●	●	●	●	○	○	○	○	○
SCZ 25	●	●	●	●	●	●	●	●	●	●	●	●	●	●	●	●	●	○	○	○	○	○
SCZ 26	●	●	●	●	●	●	●	●	●	●	●	●	●	●	●	●	●	○	○	○	○	○
SCZ 29	●	●	●	●	●	●	●	●	●	●	●	●	●	●	●	●	●	○	○	○	○	○
SCZ 30	●	●	●	●	●	●	●	●	●	●	●	●	●	●	●	●	●	○	○	○	○	○
SKZ 20	●	●	●	●	●	●	●	●	●	●	●	●	●	●	●	●	●	○	○	○	○	○
SKZ 22	●	●	●	●	●	●	●	●	●	●	●	●	●	●	●	●	●	○	○	○	○	○
SKZ 23	●	●	●	●	●	●	●	●	●	●	●	●	●	●	●	●	●	○	○	○	○	○
SKZ 24	●	●	●	●	●	●	●	●	●	●	●	●	●	●	●	●	●	○	○	○	○	○
SKZ 25	●	●	●	●	●	●	●	●	●	●	●	●	●	●	●	●	●	○	○	○	○	○
SKZ 31	○	○	○	○	○	○	○	○	○	○	○	○	○	○	○	○	○	●	●	●	●	●
SKZ 33	○	○	○	○	○	○	○	○	○	○	○	○	○	○	○	○	○	●	●	●	●	●
SKZ 34	○	○	○	○	○	○	○	○	○	○	○	○	○	○	○	○	○	●	●	●	●	●
SKZ 36	○	○	○	○	○	○	○	○	○	○	○	○	○	○	○	○	○	●	●	●	●	●
SKZ 38	○	○	○	○	○	○	○	○	○	○	○	○	○	○	○	○	○	●	●	●	●	●

● Interlock compatible ○ Interlock not compatible

Available Steel Grades					
ASTM	YIELD STRENGTH		ASTM	YIELD STRENGTH	
	(ksi)	(MPa)		(ksi)	(MPa)
A 572 Grade 50	50	345	A 572 Grade 65 (Mod)**	80	555
A 572 Grade 55	55	380	A 588	50	345
A 572 Grade 60	60	415	A 690	50	345
A 572 Grade 65*	65	450			

*Not available for thicknesses $\geq 0.375"$ (9.525mm). **Not available for thicknesses $> 0.276"$ (7.0mm).

Corner Piles

B2 Corner Pile

B3 Corner Pile

CFC 90*
12.00 lb/ft
(17.9 kg/m)

CF Tee*
17.07 lb/ft
(25.4 kg/m)

CF*
7.46 lb/ft
(11.1 kg/m)

V 20*
8.85 lb/ft
(13.2 kg/m)

SKZ 20- SKZ 38
A = 5.0 inches (127.0 mm)
B = 23.5 inches (596.9 mm)

Delivery Conditions & Tolerances

	ASTM A6		EN 10249-2	
Mass	$\pm 2.5\%$		$\pm 7\%$	
Length	+ 5 inches	- 0 inches	± 50 mm	
Straightness				
Bending (S)			0.25% of the length	
Curving (C)			0.25% of the length	
Twisting (V)			2% of the length	

Maximum Rolled Lengths†

SKZ 70 feet (21.3 m)

† Longer lengths may be possible upon request.

* Covered by one or more patents owned by PilePro, LLC (www.pilepro.com)

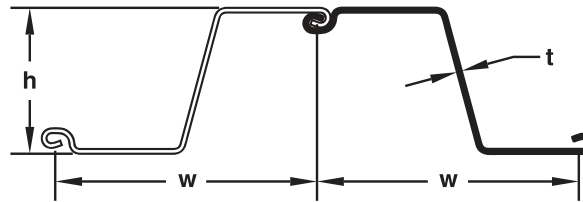

SECTION	Width (w) in (mm)	Height (h) in (mm)	Thickness (t) in (mm)	Cross Sectional Area in ² /ft (cm ² /m)	WEIGHT		SECTION MODULUS		Moment of Inertia in ⁴ /ft (cm ⁴ /m)	COATING AREA	
					Pile lb/ft (kg/m)	Wall lb/ft ² (kg/m ²)	Elastic in ³ /ft (cm ³ /m)	Plastic in ³ /ft (cm ³ /m)		Both Sides ft ² /ft (m ² /m)	Coating Area ft ² /ft ² (m ² /m ²)
SCZ 14	28.50 723.9	10.00 254.0	0.250 6.4	4.18 88.48	33.81 50.31	14.23 69.50	14.36 772	16.32 877.4	71.82 9808	6.10 1.86	1.28 1.28
SCZ 16	28.50 723.9	10.00 254.0	0.276 7.0	4.62 97.79	37.37 55.61	15.73 76.82	15.75 847	17.97 965.9	78.73 10751	6.10 1.86	1.28 1.28
SCZ 17	29.95 760.8	10.13 257.3	0.315 8.0	5.16 109.22	43.86 65.27	17.57 85.79	16.86 906	19.57 1051.9	88.77 12122	6.32 1.93	1.27 1.27
SCZ 18	29.95 760.8	10.13 257.3	0.335 8.5	5.49 116.21	46.67 69.45	18.70 91.28	17.86 960	20.85 1121.0	90.48 12356	6.32 1.93	1.27 1.27
SCZ 19	29.95 760.8	10.13 257.3	0.354 9.0	5.80 122.77	49.30 73.37	19.75 96.43	18.74 1008	22.06 1186.0	94.92 12962	6.32 1.93	1.27 1.27
SCZ 21	29.95 760.8	10.13 257.3	0.375 9.5	6.14 129.96	52.19 77.67	20.91 102.10	19.85 1067	23.26 1250.5	100.55 13731	6.32 1.93	1.27 1.27
SCZ 22	24.02 610.0	13.39 340.0	0.315 8.0	6.43 136.20	43.81 65.19	21.89 106.90	29.76 1600	33.75 1814.8	199.19 27200	5.91 1.80	1.48 1.48
SCZ 23	24.02 610.0	13.39 340.0	0.335 8.5	6.87 145.40	46.84 69.70	23.35 114.00	31.62 1700	36.08 1939.9	223.63 28900	5.91 1.80	1.48 1.48
SCZ 25	24.02 610.0	13.39 340.0	0.354 9.0	7.27 153.95	49.60 73.80	24.78 121.00	33.48 1800	38.13 2050.2	224.08 30600	5.91 1.80	1.48 1.48
SCZ 26	24.02 610.0	13.39 340.0	0.375 9.5	7.68 162.50	52.28 77.80	26.22 128.00	35.34 1900	40.28 2165.8	236.53 32300	5.91 1.80	1.48 1.48
SCZ 29	24.02 610.0	13.39 340.0	0.413 10.5	8.48 179.50	57.92 86.20	28.88 141.00	39.06 2100	44.49 2392.2	261.43 35700	5.91 1.80	1.48 1.48
SCZ 30	24.02 610.0	13.39 340.0	0.433 11.0	8.88 188.00	60.68 90.30	30.31 148.00	40.92 2200	46.56 2503.2	273.88 37400	5.91 1.80	1.48 1.48

Interlock Compatibility

	SCZ 14	SCZ 16	SCZ 17	SCZ 18	SCZ 19	SCZ 21	SCZ 22	SCZ 23	SCZ 25	SCZ 26	SCZ 29	SCZ 30	SKZ 20	SKZ 22	SKZ 23	SKZ 24	SKZ 25	SKZ 31	SKZ 33	SKZ 34	SKZ 36	SKZ 38
SCZ 14	●	●	●	●	●	●	●	●	●	●	●	●	●	●	●	●	●	○	○	○	○	○
SCZ 16	●	●	●	●	●	●	●	●	●	●	●	●	●	●	●	●	●	○	○	○	○	○
SCZ 17	●	●	●	●	●	●	●	●	●	●	●	●	●	●	●	●	●	○	○	○	○	○
SCZ 18	●	●	●	●	●	●	●	●	●	●	●	●	●	●	●	●	●	○	○	○	○	○
SCZ 19	●	●	●	●	●	●	●	●	●	●	●	●	●	●	●	●	●	○	○	○	○	○
SCZ 21	●	●	●	●	●	●	●	●	●	●	●	●	●	●	●	●	●	○	○	○	○	○
SCZ 22	●	●	●	●	●	●	●	●	●	●	●	●	●	●	●	●	●	○	○	○	○	○
SCZ 23	●	●	●	●	●	●	●	●	●	●	●	●	●	●	●	●	●	○	○	○	○	○
SCZ 25	●	●	●	●	●	●	●	●	●	●	●	●	●	●	●	●	●	○	○	○	○	○
SCZ 26	●	●	●	●	●	●	●	●	●	●	●	●	●	●	●	●	●	○	○	○	○	○
SCZ 29	●	●	●	●	●	●	●	●	●	●	●	●	●	●	●	●	●	○	○	○	○	○
SCZ 30	●	●	●	●	●	●	●	●	●	●	●	●	●	●	●	●	●	○	○	○	○	○
SKZ 20	●	●	●	●	●	●	●	●	●	●	●	●	●	●	●	●	●	○	○	○	○	○
SKZ 22	●	●	●	●	●	●	●	●	●	●	●	●	●	●	●	●	●	○	○	○	○	○
SKZ 23	●	●	●	●	●	●	●	●	●	●	●	●	●	●	●	●	●	○	○	○	○	○
SKZ 24	●	●	●	●	●	●	●	●	●	●	●	●	●	●	●	●	●	○	○	○	○	○
SKZ 25	●	●	●	●	●	●	●	●	●	●	●	●	●	●	●	●	●	○	○	○	○	○
SKZ 31	○	○	○	○	○	○	○	○	○	○	○	○	○	○	○	○	○	●	●	●	●	●
SKZ 33	○	○	○	○	○	○	○	○	○	○	○	○	○	○	○	○	○	●	●	●	●	●
SKZ 34	○	○	○	○	○	○	○	○	○	○	○	○	○	○	○	○	○	●	●	●	●	●
SKZ 36	○	○	○	○	○	○	○	○	○	○	○	○	○	○	○	○	○	●	●	●	●	●
SKZ 38	○	○	○	○	○	○	○	○	○	○	○	○	○	○	○	○	○	●	●	●	●	●

● Interlock compatible ○ Interlock not compatible

SCZ

SCZ Cold Formed Steel Sheet Pile

Available Steel Grades					
ASTM	YIELD STRENGTH		ASTM	YIELD STRENGTH	
	(ksi)	(MPa)		(ksi)	(MPa)
A 572 Grade 50	50	345	A 572 Grade 65 (Mod)**	80	555
A 572 Grade 55	55	380	A 588	50	345
A 572 Grade 60	60	415	A 690	50	345
A 572 Grade 65*	65	450			

*Not available for thicknesses $\geq 0.375"$ (9.525mm). **Not available for thicknesses $> 0.276"$ (7.0mm).

Corner Piles

B2 Corner Pile

B3 Corner Pile

CFC 90*
12.00 lb/ft
(17.9 kg/m)

CF Tee*
17.07 lb/ft
(25.4 kg/m)

CF*
7.46 lb/ft
(11.1 kg/m)

V 20*
8.85 lb/ft
(13.2 kg/m)

SCZ 14 - SCZ 16
A = 5.0 inches
(127.0 mm)
B = 23.5 inches
(596.9 mm)

SCZ 17 - SCZ 21
A = 5.0 inches
(127.0 mm)
B = 24.95 inches
(633.7 mm)

SCZ 22 - SCZ 30
A = 5.0 inches
(127.0 mm)
B = 19.0 inches
(482.6 mm)

Delivery Conditions & Tolerances

	ASTM A6		EN 10249-2	
Mass	$\pm 2.5\%$		$\pm 7\%$	
Length	+ 5 inches	- 0 inches	± 50 mm	
Straightness				
Bending (S)			0.25% of the length	
Curving (C)			0.25% of the length	
Twisting (V)			2% of the length	

Maximum Rolled Lengths†

SCZ 70 feet (21.3 m)

† Longer lengths may be possible upon request.

* Covered by one or more patents owned by PilePro, LLC (www.pilepro.com)

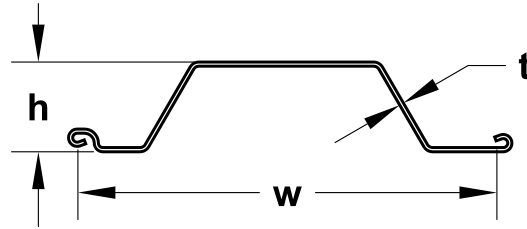

SECTION	Width (w) in (mm)	Height (h) in (mm)	Thickness (t) in (mm)	Cross Sectional Area in ² /ft (cm ² /m)	WEIGHT		SECTION MODULUS		Moment of Inertia in ⁴ /ft (cm ⁴ /m)	COATING AREA	
					Pile lb/ft (kg/m)	Wall lb/ft ² (kg/m ²)	Elastic in ³ /ft (cm ³ /m)	Plastic in ³ /ft (cm ³ /m)		Both Sides ft ² /ft (m ² /m)	Coating Area ft ² /ft ² (m ² /m ²)
SKL 9	21.65 550	3.54 90	0.157 4.0	2.53 53.50	15.52 23.10	8.60 42.00	2.55 137	3.28 176.43	4.50 615	4.23 1.29	1.17 1.17
SKL 10	21.65 550	3.54 90	0.177 4.5	2.83 59.90	17.40 25.90	9.63 47.00	2.88 155	3.67 197.23	5.09 695	4.23 1.29	1.17 1.17
SKL 12	21.65 550	3.54 90	0.217 5.5	3.43 72.60	21.10 31.40	11.67 57.00	3.53 190	4.42 237.66	6.22 850	4.23 1.29	1.17 1.17
SKS 11	27.56 700	5.91 150	0.197 5.0	3.29 69.60	25.69 38.23	11.26 55.00	6.34 341	7.54 405.36	18.67 2550	5.87 1.79	1.28 1.28
SKS 13	27.56 700	5.91 150	0.217 5.5	3.61 76.40	28.22 42.00	12.29 60.00	6.98 375	8.44 454.03	20.48 2810	5.87 1.79	1.28 1.28
SKS 14	27.56 700	5.91 150	0.250 6.4	4.17 88.20	32.58 48.49	14.19 69.27	8.05 433	9.48 509.87	23.78 3247	5.87 1.79	1.28 1.28
SKS 16	27.56 700	5.91 150	0.276 7.0	4.57 96.70	35.61 53.00	15.57 76.00	8.89 478	10.40 559.20	26.25 3585	5.87 1.79	1.28 1.28

Interlock Compatibility

	SKL 9	SKL 10	SKL 12	SKS 11	SKS 13	SKS 14	SKS 16
SKL 9	●	●	●	●	●	●	●
SKL 10	●	●	●	●	●	●	●
SKL 12	●	●	●	●	●	●	●
SKS 11	●	●	●	●	●	●	●
SKS 13	●	●	●	●	●	●	●
SKS 14	●	●	●	●	●	●	●
SKS 16	●	●	●	●	●	●	●

● Interlock compatible ○ Interlock not compatible

SKL/SKS

SKL/SKS Cold Formed Steel Sheet Pile

Available Steel Grades					
ASTM	YIELD STRENGTH		ASTM	YIELD STRENGTH	
	(ksi)	(MPa)		(ksi)	(MPa)
A 572 Grade 50	50	345	A 572 Grade 65 (Mod)**	80	555
A 572 Grade 55	55	380	A 588	50	345
A 572 Grade 60	60	415	A 690	50	345
A 572 Grade 65*	65	450			

*Not available for thicknesses $\geq 0.375"$ (9.525mm). **Not available for thicknesses $> 0.276"$ (7.0mm).

Corner Piles

D1 Corner Piles

D3 Corner Piles

CFC 90*
12.00 lb/ft
(17.9 kg/m)

CF Tee*
17.07 lb/ft
(25.4 kg/m)

CF*
7.46 lb/ft
(11.1 kg/m)

V 20*
8.85 lb/ft
(13.2 kg/m)

SKL 9-12
A = 10.8 inches (275.0 mm)

SKS 11-16
A = 13.8 inches (350.0 mm)

Delivery Conditions & Tolerances

	ASTM A6		EN 10249-2	
Mass	$\pm 2.5\%$		$\pm 7\%$	
Length	+ 5 inches	- 0 inches	± 50 mm	
Straightness				
Bending (S)			0.25% of the length	
Curving (C)			0.25% of the length	
Twisting (V)			2% of the length	

Standard Rolled Lengths*

SKL, SKS 70 feet (21.3 m)

† Longer lengths may be possible upon request.

* Covered by one or more patents owned by PilePro, LLC (www.pilepro.com)

Combination Wall Systems

Combined wall systems are used when regular sheet piles are not strong enough to carry the required loads. The two main components of a combined wall system are the king pile (HZM or Pipe) and a pair of intermediary sheet piles. The connector is the third component and is welded to or interlocked with the king pile and connects the king pile to the sheet pile. The intermediary sheet piles transfer the soil and water pressures to the king piles, which carry most of the load. The sheet piles are usually shorter, varying from 60% to 100% of the length of the king pile. The king piles are often designed to carry substantial vertical loads in addition to the normal bending loads.

There are a wide variety of HZM and Pipe solutions which give the designer a great deal of flexibility. Each type of system, beam and pipe, have their own advantages. The HZM system is fully interlocking and does not rely on any welded connections. The HZM system also has a shallower depth than the pipe system which reduces the encroachment into waterways. The Pipe-Z system has a much greater range of strengths than the HZM system because of the very large pipes that can be manufactured for the system. It also usually has higher strength to weight and stiffness to weight ratios than the HZM system. Whichever system is chosen, the engineer can rest assured that both systems have proven themselves on large infrastructure projects around the world.

Applications of Combined Wall Systems

Combined wall systems provide an ideal solution for applications such as: large capacity retaining walls with deep excavations, breakwaters, deep cofferdams, and other structures that require retaining walls to resist large loads.

Pipe AZ System

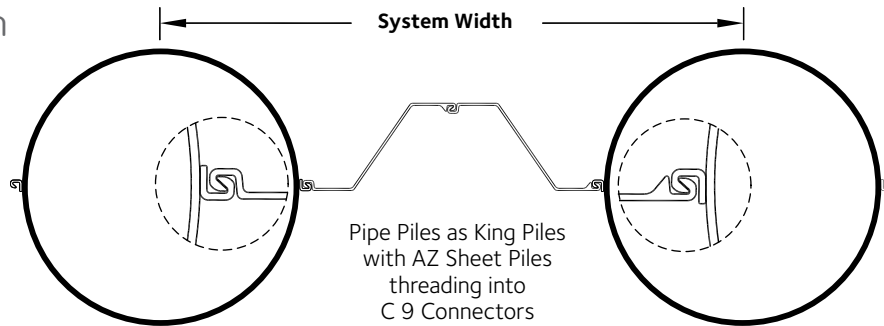

Pipe AZ System Combination Sample*	Sheet Pile Section	PROPERTIES OF PIPE PILE			PROPERTIES OF COMBINED WALL							COATING	
		Outside Diameter	Wall Thickness	Pipe Weight	System Width	System Inertia	Section Modulus	WEIGHT (Sheet Pile Length/Pipe Length)			Cross Sectional Area		Both Sides of Wall
								100%	80%	60%			
in mm	in mm	lb/ft kg/m	in mm	in ⁴ /ft ² cm ⁴ /m	in ³ /ft cm ³ /m	100% lb/ft ² kg/m ²	80% lb/ft ² kg/m ²	60% lb/ft ² kg/m ²	in ² /ft ² cm ² /m ²	ft ² /ft ² m ² /m ²			
PAZ24/AZ14-770	AZ14-770	24 609.6	0.250 6.4	63.47 94.5	87.13 2213.10	363 49530	23.5 1263.4	25.2 122.9	21.9 106.9	18.6 90.8	6.89 145.9	18.5 5.6	
PAZ24/AZ19-700	AZ19-700	24 609.6	0.375 9.5	94.71 140.9	81.62 2073.10	608 82959	38.7 2080.6	31.6 154.1	28.0 136.9	24.5 119.7	8.74 185.0	18.5 5.6	
PAZ24/AZ26-700	AZ26-700	24 609.6	0.500 12.7	125.61 186.9	81.62 2073.10	868 118464	54.0 2903.2	40.6 198.4	36.2 176.8	31.8 155.1	11.40 241.3	18.9 5.8	
PAZ24/AZ 38-700N	AZ 38-700N	24 609.6	0.625 15.9	156.17 232.4	81.62 2073.15	1212 165536	73.5 3951.6	49.8 243.0	44.4 216.8	39.0 190.7	14.09 298.2	19.8 6.0	
PAZ30/AZ14-770	AZ14-770	30 762.0	0.312 7.9	99.02 147.4	93.13 2365.50	597 81457	33.3 1790.3	28.1 137.4	25.1 122.4	22.0 107.3	7.79 165.0	20.1 6.1	
PAZ30/AZ19-700	AZ19-700	30 762.0	0.375 9.5	118.76 176.7	87.62 2225.50	836 114217	45.6 2451.6	32.7 159.7	29.4 143.6	26.1 127.6	9.11 192.8	20.1 6.1	
PAZ30/AZ26-700	AZ26-700	30 762.0	0.500 12.7	157.68 234.7	87.62 2225.50	1169 159596	62.7 3370.9	42.2 206.3	38.1 186.1	34.0 165.9	11.91 252.1	20.5 6.3	
PAZ30/AZ 38-700N	AZ 38-700N	30 762.0	0.625 15.9	196.26 292.1	87.62 2225.55	1581 215898	89.3 4801.0	51.9 253.2	46.9 228.8	41.9 204.4	14.74 311.9	21.4 6.5	
PAZ36/AZ14-770	AZ14-770	36 914.4	0.375 9.5	142.81 212.5	99.13 2517.90	989 135070	48.5 2607.5	31.7 154.9	28.8 140.8	26.0 126.7	8.88 188.0	21.6 6.6	
PAZ36/AZ19-700	AZ19-700	36 914.4	0.438 11.1	166.32 247.5	93.62 2377.90	1299 177403	62.5 3360.2	36.7 179.2	33.6 164.2	30.5 149.2	10.32 218.4	21.6 6.6	
PAZ36/AZ26-700	AZ26-700	36 914.4	0.500 12.7	189.75 282.4	93.62 2377.90	1588 216868	74.5 4005.4	43.7 213.1	39.8 194.2	35.9 175.4	12.35 261.5	22.1 6.7	
PAZ36/AZ 38-700N	AZ 38-700N	36 914.4	0.750 19.1	282.62 420.6	93.62 2377.95	2379 324804	111.9 6016.1	59.6 291.0	54.9 268.2	50.3 245.3	17.05 360.8	22.9 7.0	
PAZ42/AZ14-770	AZ14-770	42 1066.8	0.438 11.1	194.38 289.3	105.13 2670.30	1589 217005	69.1 3715.0	35.8 174.8	33.1 161.5	30.4 148.2	10.10 213.9	23.2 7.1	
PAZ42/AZ19-700	AZ19-700	42 1066.8	0.500 12.7	221.82 330.1	99.62 2530.30	1993 272215	85.4 4593.0	41.2 201.0	38.3 186.9	35.4 172.8	11.66 246.8	23.2 7.1	
PAZ42/AZ26-700	AZ26-700	42 1066.8	0.625 15.9	276.44 411.4	99.62 2530.30	2555 348961	108.1 5811.8	51.5 251.3	47.8 233.5	44.2 215.8	14.68 310.7	23.7 7.2	
PAZ42/AZ 38-700N	AZ 38-700N	42 1066.8	0.750 19.1	330.72 492.2	99.62 2530.35	3188 435375	133.1 7155.9	61.8 301.8	57.4 280.3	53.0 258.9	17.72 375.1	24.5 7.5	

* Additional combinations are available upon request.

Pipe-Z

Pipe-Z Combined Wall Systems

Pipe AZ System

Pipe AZ System Combination Sample*	Sheet Pile Section	PROPERTIES OF PIPE PILE			PROPERTIES OF COMBINED WALL							COATING	
		Outside Diameter	Wall Thickness	Pipe Weight	System Width	System Inertia	Section Modulus	WEIGHT (Sheet Pile Length/Pipe Length)			Cross Sectional Area		Both Sides of Wall
								100%	80%	60%			
in mm	in mm	lb/ft kg/m	in mm	in ⁴ /ft ² cm ⁴ /m	in ³ /ft ² cm ³ /m	100% lb/ft ² kg/m ²	80% lb/ft ² kg/m ²	60% lb/ft ² kg/m ²	in ² /ft ² cm ² /m	ft ² /ft ² m ² /m			
PAZ48/AZ19-700	AZ19-700	48 1219.2	0.500 12.7	253.89 377.8	105.62 2682.70	2682 366235	102.6 5516.1	42.5 207.4	39.8 194.1	37.0 180.8	12.07 255.4	24.8 7.6	
PAZ48/AZ26-700	AZ26-700	48 1219.2	0.625 15.9	316.52 471.0	105.62 2682.70	3409 465486	129.1 6940.8	53.1 259.2	49.7 242.5	46.2 225.8	15.18 321.4	25.2 7.7	
PAZ48/AZ 38-700N	AZ 38-700N	48 1219.2	0.750 19.1	378.83 563.8	105.62 2682.75	4201 573708	157.3 8456.9	63.8 311.3	59.6 291.1	55.5 270.8	18.32 387.8	26.1 8.0	
PAZ54/AZ19-700	AZ19-700	54 1371.6	0.563 14.3	321.33 478.2	111.62 2835.10	3908 533601	135.6 7290.3	47.4 231.7	44.9 219.1	42.3 206.5	13.55 286.8	26.3 8.0	
PAZ54/AZ26-700	AZ26-700	54 1371.6	0.625 15.9	356.61 530.7	111.62 2835.10	4439 606154	152.0 8172.0	54.6 266.3	51.3 250.5	48.1 234.7	15.63 330.9	26.8 8.2	
PAZ54/AZ 38-700N	AZ 38-700N	54 1371.6	0.750 19.1	426.93 635.3	111.62 2835.15	5426 741019	184.0 9892.4	65.5 319.8	61.6 300.7	57.7 281.5	18.86 399.1	27.7 8.4	
PAZ60/AZ19-700	AZ19-700	60 1524.0	0.625 15.9	396.70 590.4	117.62 2987.50	5517 753432	171.9 9241.9	52.7 257.4	50.3 245.4	47.8 233.5	15.12 320.0	27.9 8.5	
PAZ60/AZ26-700	AZ26-700	60 1524.0	0.750 19.1	475.04 706.9	117.62 2987.50	6670 910802	236.5 12715.0	63.9 311.7	60.8 296.7	57.7 281.7	18.39 389.2	28.4 8.6	
PAZ60/AZ 38-700N	AZ 38-700N	60 1524.0	0.813 20.6	514.08 765.0	117.62 2987.55	7377 1007349	229.2 12322.5	71.1 346.9	67.3 328.8	63.6 310.6	20.51 434.1	29.2 8.9	
PAZ66/AZ19-700	AZ19-700	66 1676.4	0.688 17.5	480.01 714.3	123.62 3139.90	7569 1033622	220.5 11854.8	58.2 284.4	55.9 273.0	53.6 261.6	16.76 354.8	29.5 9.0	
PAZ66/AZ26-700	AZ26-700	66 1676.4	0.750 19.1	523.14 778.5	123.62 3139.90	8346 1139687	240.7 12940.8	65.4 319.4	62.5 305.1	59.6 290.8	18.87 399.4	29.9 9.1	
PAZ66/AZ 38-700N	AZ 38-700N	66 1676.4	0.813 20.6	566.19 842.6	123.62 3139.95	9183 1254014	262.2 14096.7	72.7 354.8	69.1 337.5	65.6 320.2	21.00 444.5	30.8 9.4	
PAZ72/AZ19-700	AZ19-700	72 1828.8	0.750 19.1	571.25 850.1	129.62 3292.30	10122 1382242	272.4 14645.1	64.0 312.5	61.8 301.6	59.6 290.8	18.47 390.9	31.1 9.5	
PAZ72/AZ26-700	AZ26-700	72 1828.8	0.813 20.6	618.31 920.1	129.62 3292.30	11048 1508654	294.9 15854.8	71.2 347.6	68.4 334.0	65.6 320.4	20.58 435.7	31.5 9.6	
PAZ72/AZ 38-700N	AZ 38-700N	72 1828.8	1.000 25.4	758.99 1129.5	129.62 3292.35	13606 1858024	361.8 19451.5	87.2 425.5	83.8 409.0	80.4 392.5	25.27 534.9	32.4 9.9	
PAZ78/AZ26-700	AZ26-700	78 1981.2	0.875 22.2	721.41 1073.6	135.62 3444.70	17089 2333697	395.5 21263.3	77.2 376.8	74.5 363.8	71.8 350.7	22.35 473.2	33.1 10.1	
PAZ78/AZ 38-700N	AZ 38-700N	78 1981.2	1.000 25.4	823.13 1225.0	135.62 3444.75	19578 2673522	451.0 24247.2	89.0 434.4	85.7 418.6	82.5 402.9	25.82 546.6	33.9 10.3	
PAZ84/AZ26-700	AZ26-700	84 2133.6	0.875 22.2	777.53 1157.1	141.62 3597.10	23445 3201620	477.7 25682.7	78.7 384.1	76.1 371.6	73.6 359.1	22.80 482.7	34.7 10.6	
PAZ84/AZ 38-700N	AZ 38-700N	84 2133.6	1.000 25.4	887.27 1320.4	141.62 3597.15	26815 3661766	544.3 29263.3	90.6 442.5	87.5 427.4	84.5 412.3	26.33 557.2	35.5 10.8	

* Additional combinations are available upon request.

Pipe PZ System

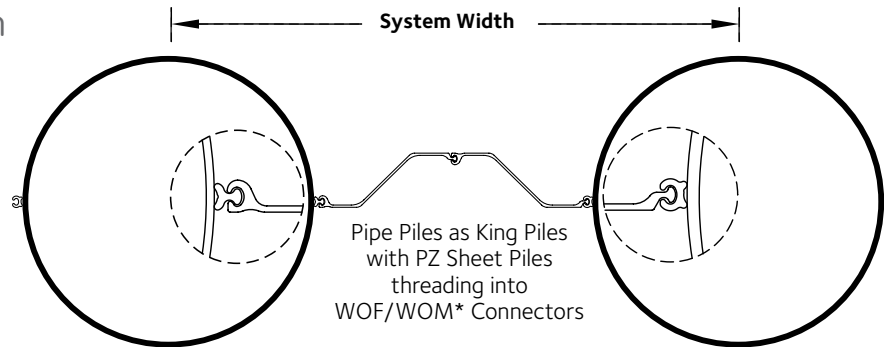

Pipe PZ System Combination Sample†	Sheet Pile Section	PROPERTIES OF PIPE PILE			PROPERTIES OF COMBINED WALL							COATING	
		Outside Diameter	Wall Thickness	Pipe Weight	System Width	System Inertia	Section Modulus	WEIGHT (Sheet Pile Length/Pipe Length)			Cross Sectional Area		Both Sides of Wall
								100%	80%	60%			
in	in	lb/ft	in	in ⁴ /ft	in ³ /ft	100%	80%	60%	in ² /ft	ft ² /ft			
mm	mm	kg/m	mm	cm ⁴ /m	cm ³ /m	lb/ft ²	lb/ft ²	lb/ft ²	cm ² /m	m ² /m			
PPZ24/PZ22	PZ22	24 609.6	0.250 6.4	63.47 94.5	70.36 1787.14	277 37840	23.1 1241.5	26.5 129.2	23.3 113.9	20.2 98.7	7.23 153.0	15.2 4.6	
PPZ24/PZ27	PZ27	24 609.6	0.500 12.7	125.61 186.9	62.36 1583.94	597 81513	49.7 2674.3	41.9 204.5	38.3 187.2	34.8 169.9	11.69 247.4	15.2 4.6	
PPZ24/PZ35	PZ35	24 609.6	0.625 15.9	156.17 232.4	71.64 1819.54	754 102935	62.8 3377.1	50.1 244.8	45.3 221.3	40.5 197.9	14.19 300.4	17.0 5.2	
PPZ24/PZ40	PZ40	24 609.6	0.750 19.1	186.41 277.4	65.73 1669.54	970 132528	80.9 4348.0	60.0 293.1	54.8 267.7	49.6 242.3	17.05 360.9	17.0 5.2	
PPZ30/PZ22	PZ22	30 762.0	0.375 9.5	118.76 176.7	76.36 1939.54	650 88820	43.4 2331.2	33.1 161.5	30.2 147.4	27.3 133.3	9.21 195.0	16.8 5.1	
PPZ30/PZ27	PZ27	30 762.0	0.500 12.7	157.68 234.7	68.36 1736.34	982 134116	65.5 3520.1	43.8 214.1	40.6 198.3	37.4 182.5	12.32 260.7	16.8 5.1	
PPZ30/PZ35	PZ35	30 762.0	0.625 15.9	196.26 292.1	77.64 1971.94	1173 160140	78.2 4203.2	52.5 256.1	48.0 234.5	43.6 212.9	14.92 315.7	18.6 5.7	
PPZ30/PZ40	PZ40	30 762.0	0.750 19.1	234.51 349.0	71.73 1821.94	1503 205283	100.2 5388.0	63.1 307.8	58.3 284.6	53.5 261.3	17.99 380.8	18.6 5.7	
PPZ36/PZ22	PZ22	36 914.4	0.375 9.5	142.81 212.5	82.36 2091.94	1015 138647	56.4 3032.5	34.2 166.8	31.5 153.8	28.8 140.7	9.57 202.6	18.4 5.6	
PPZ36/PZ27	PZ27	36 914.4	0.500 12.7	189.75 282.4	74.36 1888.74	1507 205802	83.7 4501.4	45.5 222.1	42.5 207.5	39.5 193.0	12.84 271.8	18.4 5.6	
PPZ36/PZ35	PZ35	36 914.4	0.625 15.9	236.35 351.7	83.64 2124.34	1755 239651	97.5 5241.7	54.4 265.8	50.3 245.8	46.2 225.7	15.54 328.9	20.2 6.1	
PPZ36/PZ40	PZ40	36 914.4	0.750 19.1	282.62 420.6	77.73 1974.34	2241 306035	124.5 6693.7	65.6 320.3	61.2 298.9	56.8 277.4	18.78 397.6	20.2 6.1	
PPZ42/PZ22	PZ22	42 1066.8	0.375 9.5	166.86 248.3	88.36 2244.34	1485 202723	70.7 3800.6	35.1 171.4	32.6 159.3	30.1 147.1	9.88 209.2	20.0 6.1	
PPZ42/PZ27	PZ27	42 1066.8	0.500 12.7	221.82 330.1	80.36 2041.14	2178 297486	103.7 5577.2	46.9 228.9	44.1 215.4	41.4 202.0	13.29 281.3	20.0 6.1	
PPZ42/PZ35	PZ35	42 1066.8	0.625 15.9	276.44 411.4	89.64 2276.74	2510 342802	119.5 6426.7	56.2 274.2	52.3 255.5	48.5 236.8	16.07 340.2	21.7 6.6	
PPZ42/PZ40	PZ40	42 1066.8	0.750 19.1	330.72 492.2	83.73 2126.74	3195 436237	152.1 8178.4	67.8 331.0	63.7 311.1	59.6 291.2	19.46 412.0	21.7 6.6	

† Additional combinations are available upon request.

* Covered by one or more patents owned by PilePro, LLC (www.pilepro.com)

Pipe-Z

Pipe-Z Combined Wall Systems

Pipe PZ System

Pipe PZ System Combination Sample†	Sheet Pile Section	PROPERTIES OF PIPE PILE					PROPERTIES OF COMBINED WALL						COATING
		Outside Diameter	Wall Thickness	Pipe Weight	System Width	System Inertia	Section Modulus	WEIGHT (Sheet Pile Length/Pipe Length)			Cross Sectional Area	Both Sides of Wall	
								100%	80%	60%			
in mm	in mm	lb/ft kg/m	in mm	in ⁴ /ft ⁴ cm ⁴ /m	in ³ /ft ³ cm ³ /m	100% lb/ft ² kg/m ²	80% lb/ft ² kg/m ²	60% lb/ft ² kg/m ²	in ² /ft ² cm ² /m	ft ² /ft m ² /m			
PPZ48/PZ22	PZ22	48 1219.2	0.500 12.7	253.89 377.8	94.36 2396.74	2716 370858	113.2 6083.6	43.9 214.6	41.6 203.2	39.3 191.8	12.51 264.7	21.5 6.6	
PPZ48/PZ27	PZ27	48 1219.2	0.563 14.3	285.25 424.5	86.36 2193.54	3354 457988	139.7 7512.9	52.4 256.0	49.9 243.5	47.3 231.0	14.96 316.6	21.5 6.6	
PPZ48/PZ35	PZ35	48 1219.2	0.625 15.9	316.52 471.0	95.64 2429.14	3446 470594	143.6 7719.7	57.7 281.6	54.1 264.0	50.5 246.5	16.54 350.2	23.3 7.1	
PPZ48/PZ40	PZ40	48 1219.2	0.750 19.1	378.83 563.8	89.73 2279.14	4371 596950	182.1 9792.5	69.7 340.3	65.9 321.7	62.1 303.1	20.05 424.5	23.3 7.1	
PPZ54/PZ22	PZ22	54 1371.6	0.563 14.3	321.33 478.2	100.36 2549.14	4068 555488	150.7 8099.9	49.4 241.1	47.2 230.4	45.0 219.7	14.13 299.0	23.1 7.0	
PPZ54/PZ27	PZ27	54 1371.6	0.625 15.9	356.61 530.7	92.36 2345.94	4921 672064	182.3 9799.7	58.3 284.6	55.9 272.9	53.5 261.3	16.71 353.7	23.1 7.0	
PPZ54/PZ35	PZ35	54 1371.6	0.750 19.1	426.93 635.3	101.64 2581.54	5413 739139	200.5 10777.8	67.3 328.6	63.9 312.1	60.5 295.6	19.40 410.6	24.9 7.6	
PPZ54/PZ40	PZ40	54 1371.6	0.875 22.2	496.92 739.5	95.73 2431.54	6662 909698	246.7 13264.8	80.1 391.3	76.6 373.8	73.0 356.4	23.15 489.9	24.9 7.6	
PPZ60/PZ27	PZ27	60 1524.0	0.625 15.9	396.70 590.4	98.36 2498.34	6336 865217	211.2 11354.6	59.6 291.1	57.4 280.2	55.1 269.2	17.13 362.6	24.7 7.5	
PPZ60/PZ35	PZ35	60 1524.0	0.750 19.1	475.04 706.9	107.64 2733.94	6983 953571	232.8 12514.1	68.9 336.5	65.7 320.9	62.5 305.3	19.89 421.1	26.4 8.1	
PPZ60/PZ40	PZ40	60 1524.0	1.000 25.4	630.71 938.6	101.73 2583.94	9706 1325482	323.5 17394.8	91.2 445.2	87.8 428.8	84.5 412.4	26.42 559.2	26.4 8.1	
PPZ66/PZ27	PZ27	66 1676.4	0.688 17.5	480.01 714.3	104.36 2650.74	8714 1189907	264.0 14196.0	65.8 321.2	63.7 310.8	61.5 300.5	18.96 401.3	26.2 8.0	
PPZ66/PZ35	PZ35	66 1676.4	0.875 22.2	609.16 906.5	113.64 2886.34	10168 1388561	308.1 16566.0	79.4 387.8	76.4 373.1	73.4 358.3	23.00 486.9	28.0 8.5	
PPZ66/PZ40	PZ40	66 1676.4	1.000 25.4	694.85 1034.1	107.73 2736.34	12195 1665330	369.5 19868.0	93.3 455.3	90.1 439.8	86.9 424.4	27.05 572.5	28.0 8.5	
PPZ72/PZ27	PZ27	72 1828.8	0.750 19.1	571.25 850.1	110.36 2803.14	11645 1590222	323.5 17390.9	72.1 352.2	70.1 342.4	68.1 332.6	20.84 441.2	27.8 8.5	
PPZ72/PZ35	PZ35	72 1828.8	0.875 22.2	665.29 990.1	119.64 3038.74	12540 1712378	348.3 18726.8	81.1 395.9	78.2 381.9	75.3 367.9	23.51 497.5	29.6 9.0	
PPZ72/PZ40	PZ40	72 1828.8	1.000 25.4	758.99 1129.5	113.73 2888.74	15003 2048761	416.7 22405.6	95.1 464.4	92.1 449.7	89.1 435.0	27.61 584.4	29.6 9.0	
PPZ78/PZ35	PZ35	78 1981.2	0.813 20.6	670.42 997.7	125.64 3191.14	14147 1931849	362.7 19501.8	77.7 379.4	75.0 366.0	72.2 352.7	22.53 476.8	31.2 9.5	
PPZ78/PZ40	PZ40	78 1981.2	1.000 25.4	823.13 1225.0	119.73 3041.14	18133 2476190	464.9 24996.9	96.8 472.5	93.9 458.5	91.1 444.6	28.12 595.1	31.2 9.5	
PPZ84/PZ35	PZ35	84 2133.6	0.875 22.2	777.53 1157.1	131.64 3343.54	18118 2474144	431.4 23192.2	83.9 409.8	81.3 397.0	78.7 384.3	24.37 515.8	32.7 10.0	
PPZ84/PZ40	PZ40	84 2133.6	1.000 25.4	887.27 1320.4	125.73 3193.54	21588 2947950	514.0 27633.6	98.3 479.8	95.6 466.5	92.8 453.3	28.57 604.8	32.7 10.0	

† Additional combinations are available upon request.

* Covered by one or more patents owned by PilePro, LLC (www.pilepro.com)

Pipe PZ-XL System

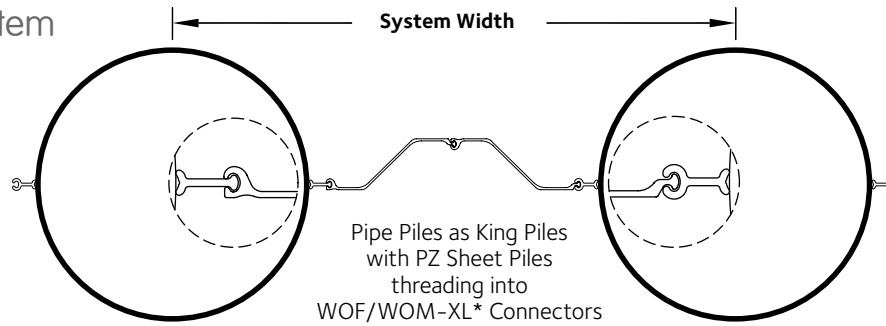

Pipe PZ-XL System Combination Sample†	Sheet Pile Section	PROPERTIES OF PIPE PILE			PROPERTIES OF COMBINED WALL							COATING Both Sides of Wall ft ² /ft m ² /m
		Outside Diameter in mm	Wall Thickness in mm	Pipe Weight lb/ft kg/m	System Width in mm	System Inertia in ⁴ /ft cm ⁴ /m	Section Modulus in ³ /ft cm ³ /m	WEIGHT (Sheet Pile Length/Pipe Length)			Cross Sectional Area in ² /ft cm ² /m	
								100% lb/ft ² kg/m ²	80% lb/ft ² kg/m ²	60% lb/ft ² kg/m ²		
PPZ24/PZ22	PZ22	24 609.6	0.250 6.4	63.47 94.5	75.10 1907.54	260 35452	21.6 1163.1	24.8 121.0	21.9 106.7	18.9 92.4	6.77 143.3	15.2 4.6
PPZ24/PZ27	PZ27	24 609.6	0.500 12.7	125.61 186.9	67.10 1704.34	555 75755	46.2 2485.4	38.9 190.1	35.6 174.0	32.3 157.9	10.86 229.9	15.2 4.6
PPZ24/PZ35	PZ35	24 609.6	0.625 15.9	156.17 232.4	76.38 1939.94	707 96547	58.9 3167.6	47.0 229.6	42.5 207.6	38.0 185.7	13.31 281.8	17.0 5.2
PPZ24/PZ40	PZ40	24 609.6	0.750 19.1	186.41 277.4	70.47 1789.94	905 123614	75.4 4055.6	56.0 273.4	51.1 249.7	46.3 226.0	15.90 336.6	17.0 5.2
PPZ30/PZ22	PZ22	30 762.0	0.375 9.5	118.76 176.7	81.10 2059.94	612 83629	40.8 2195.0	31.1 152.0	28.4 138.8	25.7 125.5	8.67 183.6	16.8 5.1
PPZ30/PZ27	PZ27	30 762.0	0.500 12.7	157.68 234.7	73.10 1856.74	918 125420	61.2 3291.9	41.0 200.2	38.0 185.4	35.0 170.7	11.52 243.8	16.8 5.1
PPZ30/PZ35	PZ35	30 762.0	0.625 15.9	196.26 292.1	82.38 2092.34	1105 150926	73.7 3961.3	49.4 241.4	45.3 221.0	41.1 200.6	14.06 297.6	18.6 5.7
PPZ30/PZ40	PZ40	30 762.0	0.750 19.1	234.51 349.0	76.47 1942.34	1410 192559	94.0 5054.0	59.1 288.8	54.7 266.9	50.2 245.1	16.87 357.2	18.6 5.7
PPZ36/PZ22	PZ22	36 914.4	0.375 9.5	142.81 212.5	87.10 2212.34	960 131102	53.3 2867.5	32.3 157.7	29.8 145.4	27.3 133.1	9.05 191.6	18.4 5.6
PPZ36/PZ27	PZ27	36 914.4	0.500 12.7	189.75 282.4	79.10 2009.14	1417 193470	78.7 4231.6	42.8 208.7	40.0 195.1	37.2 181.5	12.07 255.6	18.4 5.6
PPZ36/PZ35	PZ35	36 914.4	0.625 15.9	236.35 351.7	88.38 2244.74	1661 226797	92.3 4960.6	51.5 251.5	47.6 232.6	43.7 213.6	14.70 311.2	20.2 6.1
PPZ36/PZ40	PZ40	36 914.4	0.750 19.1	282.62 420.6	82.47 2094.74	2112 288446	117.3 6309.0	61.8 301.9	57.7 281.7	53.6 261.5	17.70 374.7	20.2 6.1
PPZ42/PZ22	PZ22	42 1066.8	0.375 9.5	166.86 248.3	93.10 2364.74	1409 192401	67.1 3607.1	33.3 162.7	31.0 151.2	28.6 139.6	9.38 198.5	20.0 6.1
PPZ42/PZ27	PZ27	42 1066.8	0.500 12.7	221.82 330.1	85.10 2161.54	2057 280916	98.0 5266.5	44.3 216.1	41.7 203.4	39.1 190.8	12.55 265.7	20.0 6.1
PPZ42/PZ35	PZ35	42 1066.8	0.625 15.9	276.44 411.4	94.38 2397.14	2384 325585	113.5 6104.0	53.3 260.4	49.7 242.7	46.1 224.9	15.27 323.1	21.7 6.6
PPZ42/PZ40	PZ40	42 1066.8	0.750 19.1	330.72 492.2	88.47 2247.14	3023 412864	144.0 7740.3	64.2 313.3	60.3 294.5	56.4 275.6	18.42 389.9	21.7 6.6

† Additional combinations are available upon request.

* Covered by one or more patents owned by PilePro, LLC (www.pilepro.com)

Pipe-Z

Pipe-Z Combined Wall Systems

Pipe PZ-XL System

Pipe PZ-XL System Combination Sample†	Sheet Pile Section	PROPERTIES OF PIPE PILE			PROPERTIES OF COMBINED WALL							COATING	
		Outside Diameter in mm	Wall Thickness in mm	Pipe Weight lb/ft kg/m	System Width in mm	System Inertia in ⁴ /ft cm ⁴ /m	Section Modulus in ³ /ft cm ³ /m	WEIGHT (Sheet Pile Length/Pipe Length)			Cross Sectional Area in ² /ft cm ² /m	Both Sides of Wall ft ² /ft m ² /m	
								100% lb/ft ² kg/m ²	80% lb/ft ² kg/m ²	60% lb/ft ² kg/m ²			
PPZ48/PZ22	PZ22	48 1219.2	0.500 12.7	253.89 377.8	99.10 2517.14	2586 353120	107.7 5792.7	41.8 204.3	39.6 193.5	37.4 182.6	11.91 252.0	21.5 6.6	
PPZ48/PZ27	PZ27	48 1219.2	0.563 14.3	285.25 424.5	91.10 2313.94	3179 434158	132.5 7122.0	49.7 242.7	47.3 230.8	44.9 219.0	14.18 300.1	21.5 6.6	
PPZ48/PZ35	PZ35	48 1219.2	0.625 15.9	316.52 471.0	100.38 2549.54	3283 448372	136.8 7355.2	54.9 268.3	51.5 251.6	48.1 234.9	15.76 333.6	23.3 7.1	
PPZ48/PZ40	PZ40	48 1219.2	0.750 19.1	378.83 563.8	94.47 2399.54	4152 566999	173.0 9301.2	66.2 323.2	62.6 305.6	59.0 287.9	19.05 403.2	23.3 7.1	
PPZ54/PZ22	PZ22	54 1371.6	0.563 14.3	321.33 478.2	105.10 2669.54	3884 530436	143.9 7734.6	47.2 230.2	45.1 220.0	43.0 209.8	13.49 285.6	23.1 7.0	
PPZ54/PZ27	PZ27	54 1371.6	0.625 15.9	356.61 530.7	97.10 2466.34	4681 639257	173.4 9321.3	55.5 270.7	53.2 259.6	50.9 248.5	15.90 336.5	23.1 7.0	
PPZ54/PZ35	PZ35	54 1371.6	0.750 19.1	426.93 635.3	106.38 2701.94	5171 706204	191.5 10297.5	64.3 314.0	61.1 298.2	57.8 282.4	18.53 392.3	24.9 7.6	
PPZ54/PZ40	PZ40	54 1371.6	0.875 22.2	496.92 739.5	100.47 2551.94	6347 866780	235.1 12639.0	76.4 372.8	73.0 356.2	69.6 339.6	22.05 466.8	24.9 7.6	
PPZ60/PZ27	PZ27	60 1524.0	0.625 15.9	396.70 590.4	103.10 2618.74	6045 825439	201.5 10832.6	56.9 277.8	54.7 267.3	52.6 256.8	16.34 345.9	24.7 7.5	
PPZ60/PZ35	PZ35	60 1524.0	0.750 19.1	475.04 706.9	112.38 2854.34	6688 913349	222.9 11986.2	66.0 322.3	62.9 307.3	59.9 292.4	19.05 403.3	26.4 8.1	
PPZ60/PZ40	PZ40	60 1524.0	1.000 25.4	630.71 938.6	106.47 2704.34	9274 1266472	309.1 16620.4	87.1 425.4	83.9 409.8	80.7 394.1	25.24 534.3	26.4 8.1	
PPZ66/PZ27	PZ27	66 1676.4	0.688 17.5	480.01 714.3	109.10 2771.14	8335 1138210	252.6 13579.2	62.9 307.2	60.9 297.3	58.9 287.1	18.14 383.9	26.2 8.0	
PPZ66/PZ35	PZ35	66 1676.4	0.875 22.2	609.16 906.5	118.38 3006.74	9761 1332960	295.8 15902.7	76.3 372.3	73.4 358.2	70.5 344.0	22.08 467.4	28.0 8.5	
PPZ66/PZ40	PZ40	66 1676.4	1.000 25.4	694.85 1034.1	112.47 2856.74	11681 1595145	354.0 19030.6	89.3 436.1	86.3 421.3	83.3 406.5	25.91 548.4	28.0 8.5	
PPZ72/PZ27	PZ27	72 1828.8	0.750 19.1	571.25 850.1	115.10 2923.54	11165 1524734	310.2 16674.7	69.2 337.7	67.2 328.3	65.3 318.9	19.99 423.0	27.8 8.5	
PPZ72/PZ35	PZ35	72 1828.8	0.875 22.2	665.29 990.1	124.38 3159.14	12062 1647118	335.0 18013.1	78.0 380.8	75.2 367.3	72.5 353.8	22.61 478.6	29.6 9.0	
PPZ72/PZ40	PZ40	72 1828.8	1.000 25.4	758.99 1129.5	118.47 3009.14	14403 1966790	400.1 21509.1	91.3 445.8	88.4 431.7	85.5 417.6	26.50 561.0	29.6 9.0	
PPZ78/PZ35	PZ35	78 1981.2	0.813 20.6	670.42 997.7	130.38 3311.54	13632 1861614	349.5 18792.8	74.9 365.6	72.2 352.7	69.6 339.9	21.71 459.5	31.2 9.5	
PPZ78/PZ40	PZ40	78 1981.2	1.000 25.4	823.13 1225.0	124.47 3161.54	17442 2381893	447.2 24045.0	93.1 454.5	90.3 441.1	87.6 427.7	27.04 572.4	31.2 9.5	
PPZ84/PZ35	PZ35	84 2133.6	0.875 22.2	777.53 1157.1	136.38 3463.94	17488 2388150	416.4 22386.1	81.0 395.5	78.5 383.2	76.0 370.9	23.52 497.9	32.7 10.0	
PPZ84/PZ40	PZ40	84 2133.6	1.000 25.4	887.27 1320.4	130.47 3313.94	20803 2840850	495.3 26629.7	94.7 462.4	92.1 449.6	89.5 436.8	27.53 582.8	32.7 10.0	

† Additional combinations are available upon request.

* Covered by one or more patents owned by PilePro, LLC (www.pilepro.com)

Pipe SKZ System

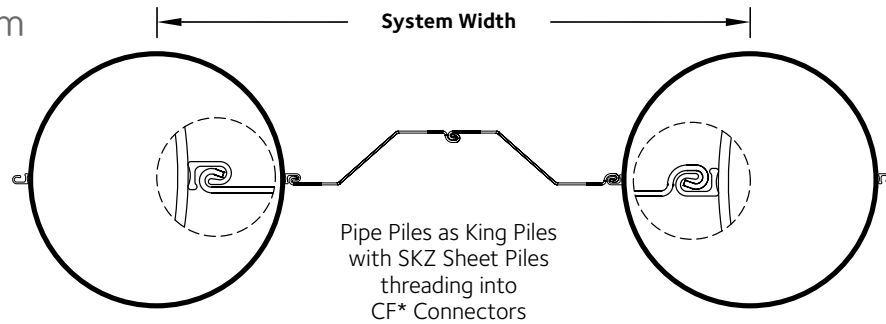

Pipe SKZ System Combination Sample [†]	Sheet Pile Section	PROPERTIES OF PIPE PILE			PROPERTIES OF COMBINED WALL							COATING	
		Outside Diameter in mm	Wall Thickness in mm	Pipe Weight lb/ft kg/m	System Width in mm	System Inertia in ⁴ /ft cm ⁴ /m	Section Modulus in ³ /ft cm ³ /m	WEIGHT (Sheet Pile Length/Pipe Length)			Cross Sectional Area in ² /ft cm ² /m		Both Sides of Wall ft ² /ft m ² /m
								100% lb/ft ² kg/m ²	80% lb/ft ² kg/m ²	60% lb/ft ² kg/m ²			
PSKZ24/SKZ20	SKZ20	24 609.6	0.250 6.4	63.47 94.5	86.86 2206.24	348 47533	29.0 1559.5	24.1 117.8	21.1 102.8	18.0 87.8	6.51 137.9	21.5 6.5	
PSKZ24/SKZ22	SKZ22	24 609.6	0.375 9.5	94.71 140.9	86.86 2206.24	444 60606	37.0 1988.4	29.3 143.0	26.0 127.2	22.8 111.3	7.98 168.9	21.5 6.5	
PSKZ24/SKZ24	SKZ24	24 609.6	0.438 11.1	110.20 164.0	86.86 2206.24	509 69461	42.4 2278.9	33.1 161.7	29.5 144.2	26.0 126.8	9.13 193.3	21.5 6.5	
PSKZ24/SKZ25	SKZ25	24 609.6	0.500 12.7	125.61 186.9	86.86 2206.24	563 76873	46.9 2522.1	36.3 177.0	32.5 158.6	28.7 140.1	10.09 213.5	21.5 6.5	
PSKZ30/SKZ20	SKZ20	30 762.0	0.375 9.5	118.76 176.7	92.86 2358.64	650 88828	43.4 2331.5	29.7 145.1	26.8 131.0	24.0 117.0	8.19 173.4	23.1 7.0	
PSKZ30/SKZ22	SKZ22	30 762.0	0.438 11.1	138.26 205.8	92.86 2358.64	738 100762	49.2 2644.7	33.0 161.2	30.0 146.4	27.0 131.6	9.12 193.0	23.1 7.0	
PSKZ30/SKZ24	SKZ24	30 762.0	0.500 12.7	157.68 234.7	92.86 2358.64	837 114278	55.8 2999.4	37.1 181.2	33.8 164.9	30.4 148.5	10.35 219.0	23.1 7.0	
PSKZ30/SKZ25	SKZ25	30 762.0	0.625 15.9	196.26 292.1	92.86 2358.64	1001 136752	66.8 3589.3	43.0 210.2	39.5 192.9	36.0 175.6	12.12 256.5	23.1 7.0	
PSKZ36/SKZ20	SKZ20	36 914.4	0.375 9.5	142.81 212.5	98.86 2511.04	954 130338	53.0 2850.8	30.8 150.5	28.1 137.3	25.4 124.2	8.55 181.1	24.6 7.5	
PSKZ36/SKZ22	SKZ22	36 914.4	0.438 11.1	166.32 247.5	98.86 2511.04	1092 149157	60.7 3262.4	34.4 168.1	31.6 154.2	28.7 140.3	9.57 202.5	24.6 7.5	
PSKZ36/SKZ24	SKZ24	36 914.4	0.500 12.7	189.75 282.4	98.86 2511.04	1241 169402	68.9 3705.2	38.8 189.2	35.6 173.9	32.5 158.5	10.86 229.9	24.6 7.5	
PSKZ36/SKZ25	SKZ25	36 914.4	0.625 15.9	236.35 351.7	98.86 2511.04	1504 205437	83.6 4493.4	45.3 221.2	42.0 205.0	38.7 188.7	12.81 271.2	24.6 7.5	
PSKZ42/SKZ20	SKZ20	42 1066.8	0.438 11.1	194.38 289.3	104.86 2663.44	1550 211606	73.8 3967.1	35.0 170.7	32.4 158.3	29.9 145.9	9.80 207.4	26.2 8.0	
PSKZ42/SKZ22	SKZ22	42 1066.8	0.500 12.7	221.82 330.1	104.86 2663.44	1752 239194	83.4 4484.3	38.8 189.5	36.1 176.4	33.4 163.2	10.88 230.4	26.2 8.0	
PSKZ42/SKZ24	SKZ24	42 1066.8	0.625 15.9	276.44 411.4	104.86 2663.44	2154 294136	102.6 5514.4	46.5 226.8	43.5 212.4	40.5 197.9	13.16 278.5	26.2 8.0	
PSKZ42/SKZ25	SKZ25	42 1066.8	0.750 19.1	330.72 492.2	104.86 2663.44	2541 347003	121.0 6505.5	53.5 261.3	50.4 246.0	47.2 230.7	15.25 322.9	26.2 8.0	

[†] Additional combinations are available upon request.

* Covered by one or more patents owned by PilePro, LLC (www.pilepro.com)

Pipe-Z

Pipe-Z Combined Wall Systems

Pipe SKZ System

Pipe SKZ System Combination Sample†	Sheet Pile Section	PROPERTIES OF PIPE PILE			PROPERTIES OF COMBINED WALL								COATING
		Outside Diameter in mm	Wall Thickness in mm	Pipe Weight lb/ft kg/m	System Width in mm	System Inertia in ⁴ /ft cm ⁴ /m	Section Modulus in ³ /ft cm ³ /m	WEIGHT (Sheet Pile Length/Pipe Length)			Cross Sectional Area in ² /ft cm ² /m	Both Sides of Wall ft ² /ft m ² /m	
								100% lb/ft ² kg/m ²	80% lb/ft ² kg/m ²	60% lb/ft ² kg/m ²			
PSKZ48/SKZ20	SKZ20	48 1219.2	0.500 12.7	253.89 377.8	110.86 2815.84	2408 328887	100.4 5395.1	39.5 192.9	37.1 181.2	34.7 169.4	11.16 236.2	27.8 8.5	
PSKZ48/SKZ22	SKZ22	48 1219.2	0.625 15.9	316.52 471.0	110.86 2815.84	2963 404597	123.5 6637.1	47.0 229.3	44.4 216.9	41.9 204.5	13.31 281.7	27.8 8.5	
PSKZ48/SKZ24	SKZ24	48 1219.2	0.750 19.1	378.83 563.8	110.86 2815.84	3519 480558	146.6 7883.2	55.0 268.7	52.2 255.0	49.4 241.3	15.70 332.3	27.8 8.5	
PSKZ48/SKZ25	SKZ25	48 1219.2	0.875 22.2	440.80 656.0	110.86 2815.84	4059 554282	169.1 9092.6	62.5 305.3	59.6 290.8	56.6 276.4	17.93 379.5	27.8 8.5	
PSKZ54/SKZ20	SKZ20	54 1371.6	0.563 14.3	321.33 478.2	116.86 2968.24	3585 489604	132.8 7139.2	44.4 216.8	42.1 205.7	39.8 194.5	12.62 267.2	29.3 8.9	
PSKZ54/SKZ22	SKZ22	54 1371.6	0.625 15.9	356.61 530.7	116.86 2968.24	3963 541226	146.8 7891.9	48.7 237.6	46.3 225.8	43.8 214.1	13.83 292.8	29.3 8.9	
PSKZ54/SKZ24	SKZ24	54 1371.6	0.750 19.1	426.93 635.3	116.86 2968.24	4715 643836	174.6 9388.1	57.1 279.0	54.5 266.0	51.8 253.0	16.35 346.0	29.3 8.9	
PSKZ54/SKZ25	SKZ25	54 1371.6	0.875 22.2	496.92 739.5	116.86 2968.24	5448 744018	201.8 10848.9	65.1 317.8	62.3 304.0	59.5 290.3	18.70 395.9	29.3 8.9	
PSKZ60/SKZ20	SKZ20	60 1524.0	0.625 15.9	396.70 590.4	122.86 3120.64	5136 701371	171.2 9204.4	49.6 242.2	47.4 231.6	45.3 221.0	14.17 299.9	30.9 9.4	
PSKZ60/SKZ22	SKZ22	60 1524.0	0.750 19.1	475.04 706.9	122.86 3120.64	6109 834171	203.6 10947.1	57.9 282.5	55.6 271.3	53.3 260.1	16.56 350.5	30.9 9.4	
PSKZ60/SKZ24	SKZ24	60 1524.0	0.875 22.2	553.04 823.0	122.86 3120.64	7078 966589	235.9 12684.9	66.7 325.5	64.1 313.1	61.6 300.8	19.17 405.7	30.9 9.4	
PSKZ60/SKZ25	SKZ25	60 1524.0	1.000 25.4	630.71 938.6	122.86 3120.64	8029 1096386	267.6 14388.3	75.0 366.0	72.3 353.0	69.6 339.9	21.63 457.8	30.9 9.4	

† Additional combinations are available upon request.

* Covered by one or more patents owned by PilePro, LLC (www.pilepro.com)

Pipe-Pipe

Pipe-Pipe Combined Wall Systems

Pipe Piles as King Piles
with WOF/WOM-XL*
Connectors

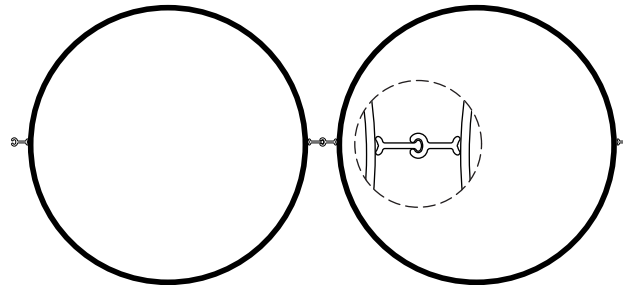

Pipe - Pipe System Combination Sample†	PROPERTIES OF PIPE PILE			PROPERTIES OF COMBINED WALL					COATING
	Outside Diameter in mm	Wall Thickness in mm	Pipe Weight lb/ft kg/m	System Width in mm	System Inertia in ⁴ /ft cm ⁴ /m	Section Modulus in ³ /ft cm ³ /m	Weight lb/ft ² kg/m ²	Cross Sectional Area in ² /ft cm ² /m	Both Sides of Wall ft ² /ft m ² /m
24 x 0.375	24.00 609.6	0.375 9.5	94.71 140.9	31.10 789.94	749 102342	62.5 3357.7	44.4 216.8	13.08 276.9	7.47 2.3
24 x 0.500	24.00 609.6	0.500 12.7	125.61 186.9	31.10 789.94	984 134329	82.0 4407.1	56.3 275.1	16.59 351.1	7.47 2.3
24 x 0.625	24.00 609.6	0.625 15.9	156.17 232.4	31.10 789.94	1210 165289	100.9 5422.9	68.1 332.6	20.05 424.5	7.47 2.3
30 x 0.375	30.00 762.0	0.375 9.5	118.76 176.7	37.10 942.34	1239 169146	82.6 4439.5	45.0 219.8	13.25 280.5	9.04 2.8
30 x 0.500	30.00 762.0	0.500 12.7	157.68 234.7	37.10 942.34	1631 222713	108.7 5845.5	57.6 281.2	16.95 358.8	9.04 2.8
30 x 0.625	30.00 762.0	0.625 15.9	196.26 292.1	37.10 942.34	2013 274913	134.2 7215.6	70.1 342.2	20.62 436.5	9.04 2.8
36 x 0.500	36.00 914.4	0.500 12.7	189.75 282.4	43.10 1094.74	2446 334059	135.9 7306.6	58.5 285.7	17.22 364.4	10.61 3.2
36 x 0.625	36.00 914.4	0.625 15.9	236.35 351.7	43.10 1094.74	3026 413225	168.1 9038.2	71.5 349.0	21.03 445.1	10.61 3.2
36 x 0.750	36.00 914.4	0.750 19.1	282.62 420.6	43.10 1094.74	3593 490701	199.6 10732.8	84.4 411.9	24.82 525.3	10.61 3.2
42 x 0.500	42.00 1066.8	0.500 12.7	221.82 330.1	49.10 1247.14	3430 468441	163.3 8782.2	59.2 289.0	17.42 368.7	12.18 3.7
42 x 0.625	42.00 1066.8	0.625 15.9	276.44 411.4	49.10 1247.14	4250 580324	202.4 10879.7	72.5 354.2	21.34 451.7	12.18 3.7
42 x 0.750	42.00 1066.8	0.750 19.1	330.72 492.2	49.10 1247.14	5054 690167	240.7 12939.0	85.8 419.0	25.24 534.2	12.18 3.7
48 x 0.500	48.00 1219.2	0.500 12.7	253.89 377.8	55.10 1399.54	4583 625902	191.0 10267.4	59.7 291.7	17.57 372.0	13.75 4.2
48 x 0.625	48.00 1219.2	0.625 15.9	316.52 471.0	55.10 1399.54	5685 776266	236.9 12734.0	73.4 358.3	21.58 456.8	13.75 4.2
48 x 0.750	48.00 1219.2	0.750 19.1	378.83 563.8	55.10 1399.54	6768 924237	282.0 15161.4	86.9 424.5	25.57 541.2	13.75 4.2

† Additional combinations are available upon request.

* Covered by one or more patents owned by PilePro, LLC (www.pilepro.com)

Pipe-Pipe

Pipe-Pipe Combined Wall Systems

Pipe - Pipe System Combination Sample†	PROPERTIES OF PIPE PILE			PROPERTIES OF COMBINED WALL					COATING
	Outside Diameter in mm	Wall Thickness in mm	Pipe Weight lb/ft kg/m	System Width in mm	System Inertia in ⁴ /ft cm ⁴ /m	Section Modulus in ³ /ft cm ³ /m	Weight lb/ft ² kg/m ²	Cross Sectional Area in ² /ft cm ² /m	Both Sides of Wall ft ² /ft m ² /m
54 x 0.625	54.00 1371.6	0.625 15.9	356.61 530.7	61.10 1551.94	7331 1001085	271.5 14597.4	74.0 361.5	21.78 460.9	15.32 4.7
54 x 0.750	54.00 1371.6	0.750 19.1	426.93 635.3	61.10 1551.94	8736 1192954	323.6 17395.1	87.9 429.0	25.84 546.8	15.32 4.7
54 x 0.875	54.00 1371.6	0.875 22.2	496.92 739.5	61.10 1551.94	10121 1382103	374.9 20153.2	101.6 496.1	29.87 632.3	15.32 4.7
60 x 0.625	60.00 1524.0	0.625 15.9	396.70 590.4	67.10 1704.34	9189 1254802	306.3 16467.2	74.6 364.2	21.94 464.3	16.89 5.1
60 x 0.750	60.00 1524.0	0.750 19.1	475.04 706.9	67.10 1704.34	10958 1496346	365.3 19637.1	88.6 432.6	26.05 551.5	16.89 5.1
60 x 0.875	60.00 1524.0	0.875 22.2	553.04 823.0	67.10 1704.34	12704 1734814	423.5 22766.6	102.6 500.7	30.15 638.2	16.89 5.1
66 x 0.750	66.00 1676.4	0.750 19.1	523.14 778.5	73.10 1856.74	13433 1834432	407.1 21885.4	89.2 435.6	26.24 555.3	18.46 5.6
66 x 0.875	66.00 1676.4	0.875 22.2	609.16 906.5	73.10 1856.74	15583 2127997	472.2 25387.7	103.3 504.6	30.39 643.2	18.46 5.6
66 x 1.000	66.00 1676.4	1.000 25.4	694.85 1034.1	73.10 1856.74	17708 2418156	536.6 28849.4	117.4 573.3	34.52 730.7	18.46 5.6
72 x 0.750	72.00 1828.8	0.750 19.1	571.25 850.1	79.10 2009.14	16163 2207223	449.0 24138.5	89.8 438.2	26.39 558.6	20.03 6.1
72 x 0.875	72.00 1828.8	0.875 22.2	665.29 990.1	79.10 2009.14	18759 2561668	521.1 28014.8	104.0 507.9	30.58 647.3	20.03 6.1
72 x 1.000	72.00 1828.8	1.000 25.4	758.99 1129.5	79.10 2009.14	21327 2912349	592.4 31849.9	118.2 577.3	34.76 735.8	20.03 6.1
78 x 0.875	78.00 1981.2	0.875 22.2	721.41 1073.6	85.10 2161.54	22231 3035839	570.0 30646.5	104.6 510.7	30.75 650.9	21.60 6.6
78 x 1.000	78.00 1981.2	1.000 25.4	823.13 1225.0	85.10 2161.54	25285 3452826	648.3 34856.0	118.9 580.8	34.97 740.1	21.60 6.6
84 x 0.875	84.00 2133.6	0.875 22.2	777.53 1157.1	91.10 2313.94	26000 3550517	619.0 33282.0	105.1 513.2	30.90 654.0	23.17 7.1
84 x 1.000	84.00 2133.6	1.000 25.4	887.27 1320.4	91.10 2313.94	29581 4039594	704.3 37866.5	119.6 583.8	35.15 744.0	23.17 7.1

† Additional combinations are available upon request.

* Covered by one or more patents owned by PilePro, LLC (www.pilepro.com)

Pipe-Z / Pipe-Pipe

Pipe-Z/Pipe-Pipe Combined Wall Systems

Available Steel Grades

SPIRALWELD PIPE		
ASTM	YIELD STRENGTH	
	(ksi)	(MPa)
A 252 Grade 1	30	205
A 252 Grade 2	35	240
A 252 Grade 3	45	310
A 252 Grade 3 (Mod)*	50-80	345-555
A 588	50	345
A 690	50	345
A 572	50	345
A 709	50	345
A 1011/1018	50	345
Abrasion Resistant	Brinell Hardness - 190	

*Availability is dependent on pipe diameter and thickness.

ROLLED & WELDED PIPE					
ASTM	YIELD STRENGTH		ASTM	YIELD STRENGTH	
	(ksi)	(MPa)		(ksi)	(MPa)
A 36	36	250	A 572 Grade 42	42	290
A 252 Grade 1	30	205	A 572 Grade 50	50	345
A 252 Grade 2	35	240	A 572 Grade 55	55	380
A 252 Grade 3	45	310	A 572 Grade 60	60	415
A 252 Grade 3 (Mod)	50	345	A 572 Grade 65	65	450
A 516 Grade 55	30	205	A 588	50	345
A 516 Grade 60	32	220			
A 516 Grade 65	35	240			
A 516 Grade 70	38	260			

Additional grades available upon request.

AZ SHEET PILES		
ASTM	YIELD STRENGTH	
	(ksi)	(MPa)
A 328	39	270
A 572 Grade 42	42	290
A 572 Grade 50	50	345
A 572 Grade 55	55	380
A 572 Grade 60	60	415
A 572 Grade 65	65	450
A 690	50	345
A 690**	57	390

PZ SHEET PILES		
ASTM	YIELD STRENGTH	
	(ksi)	(MPa)
A 328	39	270
A 572 Grade 50	50	345
A 572 Grade 60	60	415
A 572 Grade 65	65	450
A 588	50	345
A 690	50	345

SKZ SHEET PILES		
ASTM	YIELD STRENGTH	
	(ksi)	(MPa)
A 572 Grade 50	50	345
A 572 Grade 55	55	380
A 572 Grade 60	60	415
A 572 Grade 65 [†]	65	450
A 572 Grade 65 (Mod) ^{††}	80	555
A 690	50	345

**Not available for AZ 36-700N and larger. [†] Not available for thickness $\geq 0.375"$ (9.525mm). ^{††} Not available for thicknesses $> 0.276"$ (7.0mm).

C9 CONNECTORS		
ASTM	YIELD STRENGTH	
	(ksi)	(MPa)
S 355 GP	51	355
A 690	50	345

WOF/WOM CONNECTORS [‡]		
ASTM	YIELD STRENGTH	
	(ksi)	(MPa)
S355 GP		
S430 GP		
A572 Gr. 50/60		
A690		

WOF/WOM-XL CONNECTORS [‡]		
ASTM	YIELD STRENGTH	
	(ksi)	(MPa)
S355 GP		
S430 GP		
A572 Gr. 50/60		
A690		

‡ Covered by one or more patents owned by PilePro, LLC (www.pilepro.com)

Pipe-Z / Pipe-Pipe

Pipe-Z/ Pipe- Pipe Combined Wall Systems

Delivery Conditions & Tolerances

SPIRALWELD	ASTM	
Pipe Piles	± 1%	
Outside Diameter	- 5%	
Weight/Thickness	± 1 in.	

ROLLED & WELDED	ASTM	
Outside Diameter	± 1%	
Weight/Thickness	Per Specification	
Length	± 1 in.	

AZ SHEET PILES	ASTM		EN 10248	
Mass	± 2.5%		± 5%	
Length	+ 5 in.	- 0 in.	± 200 mm	
Height			± 7 mm	
Thickness			≤ 8.5 mm > 8.5 mm	± 0.5 mm ± 6%
Width			± 2%	
Double Pile Width			± 3%	
Straightness			0.2% of the length	
Ends out of Square			2% of the width	

PZ SHEET PILES	ASTM A 6	
Mass	± 2.5%	
Length	+ 5 in.	-0 in.

SKZ SHEET PILES	ASTM	
Mass	± 2.5%	
Length	+ 5 in.	- 0 in.
Interlock Opening	± 0.08 in.	
Straightness	0.2% of the length	
Twisting	0.4% of the width	

C9 CONNECTORS	ASTM		EN 10248	
Mass	± 2.5%		± 5%	
Length	+ 5 in.	- 0 in.	± 200 mm	
Height			± 7 mm	
Thickness			≤ 8.5 mm > 8.5 mm	± 0.5 mm ± 6%
Width			± 2%	
Double Pile Width			± 3%	
Straightness			0.2% of the length	
Ends out of Square			2% of the width	

Maximum Rolled Lengths*

Spiralweld	130 feet	39.6 m
Rolled & Welded	120 feet	36.6 m
C9	59 feet	18.0 m
WOF/WOM [‡]	25 feet	7.6 m
WOF/WOM-XL [‡]	25 feet	7.6 m
CF [‡]	25 feet	7.6 m
AZ	102 feet	31.0 m
PZ	85 feet for singles 70 feet for pairs	25.9 m for singles 21.3 m for pairs
SKZ	70 feet	21.3 m

* All sections are readily spliced for longer lengths.

‡ Covered by one or more patents owned by PilePro, LLC (www.pilepro.com)

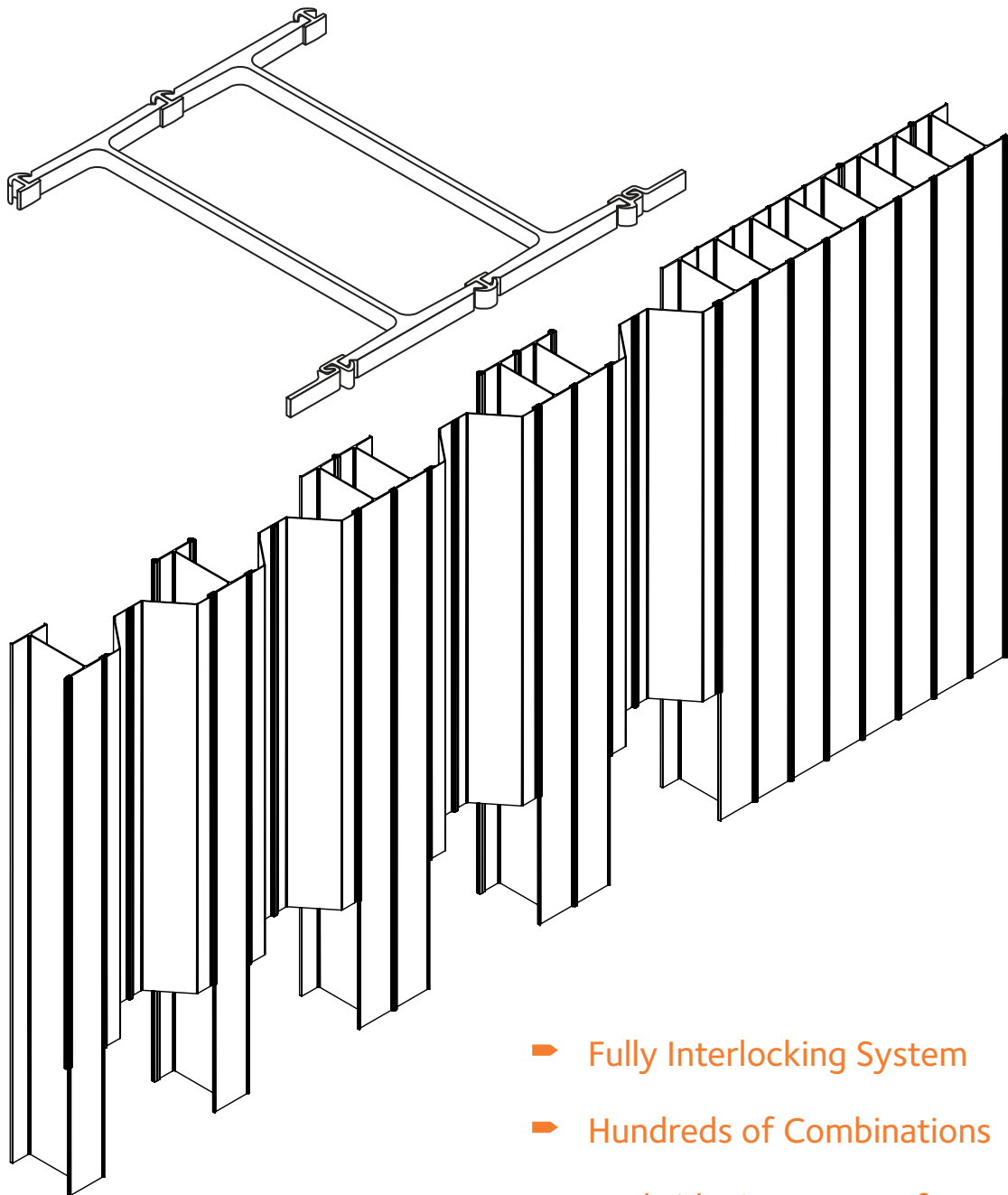

- Fully Interlocking System
- Hundreds of Combinations
- Backside Connectors for Extra Strength

HZ-M - King Pile

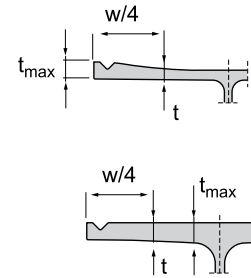
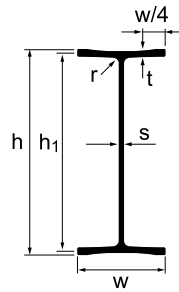

SECTION	DIMENSIONS							Suitable Connector	
	h in mm	h ₁ in mm	w in mm	t _{max} in mm	t in mm	s in mm	r in mm		
HZ 880M A	32.73 831.3	31.63 803.4	18.03 458	1.14 28.96	0.74 18.8	0.51 13.0	0.79 20	RZDU 16	RH 16
HZ 880M B	32.73 831.3	31.79 807.4	18.11 460	1.14 28.96	0.82 20.8	0.59 15.0	0.79 20	RZDU 16	RH 16
HZ 880M C	32.73 831.3	31.95 811.4	18.11 460	1.14 28.96	0.90 22.9	0.59 15.0	0.79 20	RZDU 16	RH 16
HZ 1080M A	42.33 1075.3	41.24 1047.4	17.87 454	1.14 28.96	0.77 19.6	0.63 16.0	1.38 35	RZDU 16	RH 16
HZ 1080M B	42.33 1075.3	41.47 1053.4	17.87 454	1.14 28.96	0.89 22.6	0.63 16.0	1.38 35	RZDU 16	RH 16
HZ 1080M C	42.33 1075.3	41.71 1059.4	17.95 456	1.14 28.96	1.01 25.7	0.71 18.0	1.38 35	RZDU 16	RH 16
HZ 1080M D	42.33 1075.3	42.02 1067.4	17.99 457	1.21 30.73	1.17 29.7	0.75 19.0	1.38 35	RZDU 16	RH 16
HZ 1180M A	42.34 1075.4	-	18.03 458	1.36 34.54	1.22 31.0	0.79 20.0	1.38 35	RZDU 16	RH 16
HZ 1180M B	42.50 1079.4	-	18.03 458	1.44 36.58	1.30 33.0	0.79 20.0	1.38 35	RZDU 16	RH 16
HZ 1180M C	42.65 1083.4	-	18.07 459	1.52 38.60	1.38 35.1	0.83 21.0	1.38 35	RZDU 18	RH 20
HZ 1180M D	42.81 1087.4	-	18.11 460	1.60 40.64	1.46 37.1	0.87 22.0	1.38 35	RZDU 18	RH 20

Solution 100

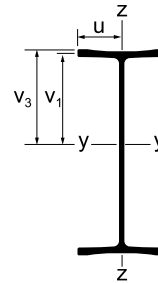

SECTION	PROPERTIES PER SOLUTION													Coating Area	
	Dimensions					Sectional Area	Mass	Moment of Inertia		Elastic Section Modulus					
	v ₁	v ₂	v ₃	v ₄	u			y-y	z-z	y-y*	y-y**	z-z	Waterside	Landside	
in mm	in mm	in mm	in mm	in mm	in ² cm ²	lb/ft kg/m	in ⁴ cm ⁴	in ⁴ cm ⁴	in ³ cm ³	in ³ cm ³	in ³ cm ³	ft ² /ft m ² /m	ft ² /ft m ² /m		
HZ 880M A	15.82 401.7	-	16.36 415.7	-	9.02 229.0	45.82 295.6	155.92 232.0	8,571.4 356770	960.8 39990	541.9 8880	-	106.5 1745	1.51 0.459	9.73 2.966	
HZ 880M B	15.89 403.7	-	16.36 415.7	-	9.06 230.0	50.87 328.2	173.13 257.6	9,435.8 392750	1,027.5 42770	593.8 9730	-	113.5 1860	1.51 0.461	9.74 2.967	
HZ 880M C	15.97 405.7	-	16.36 415.7	-	9.06 230.0	53.11 342.7	180.76 269.0	10,012.7 416760	1,065.5 44350	627.0 10275	-	117.8 1930	1.51 0.461	9.74 2.967	
HZ 1080M A	20.62 523.7	-	21.17 537.7	-	8.94 227.0	58.00 374.2	197.39 293.8	16,943.9 705260	944.9 39330	821.7 13465	-	105.9 1735	1.49 0.455	11.14 3.396	
HZ 1080M B	20.74 526.7	-	21.17 537.7	-	8.94 227.0	61.63 397.6	209.72 312.1	18,512.5 770550	1,016.5 42310	892.8 14630	-	113.8 1865	1.49 0.455	11.14 3.396	
HZ 1080M C	20.85 529.7	-	21.17 537.7	-	8.98 228.0	68.14 439.6	231.88 345.1	20,396.5 848970	1,080.2 44960	977.9 16025	-	120.2 1970	1.50 0.457	11.15 3.397	
HZ 1080M D	21.01 533.7	-	21.17 537.7	-	9.00 228.5	73.41 473.6	249.82 371.8	22,231.8 925360	1,127.7 46940	1,058.2 17340	-	125.4 2055	1.50 0.457	11.15 3.397	
HZ 1180M A	21.17 537.7	-	21.17 537.7	-	9.02 229.0	77.63 500.8	264.18 393.1	23,617.8 983050	1,152.0 47950	1,115.8 18285	-	127.8 2095	1.50 0.457	11.15 3.397	
HZ 1180M B	21.25 539.7	-	21.25 539.7	-	9.02 229.0	80.46 519.1	273.83 407.5	24,893.7 1036160	1,228.9 51150	1,171.7 19200	-	136.4 2235	1.50 0.457	11.18 3.407	
HZ 1180M C	21.33 541.7	-	21.33 541.7	-	9.04 229.5	84.98 548.3	289.21 430.4	26,434.9 1100310	1,314.9 54730	1,239.4 20310	-	145.5 2385	1.51 0.459	11.21 3.416	
HZ 1180M D	21.41 543.7	-	21.41 543.7	-	9.06 230.0	89.51 577.5	304.63 453.3	27,991.5 1165100	1,401.9 58350	1,307.7 21430	-	154.7 2535	1.53 0.460	11.24 3.425	

* Referring outside of HZM-flange. ** Referring outside of connector.

Solution 102

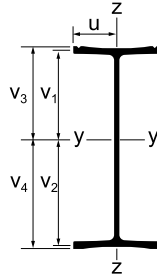

SECTION	PROPERTIES PER SOLUTION													Coating Area	
	Dimensions					Sectional Area	Mass	Moment of Inertia		Elastic Section Modulus					
	v_1 in mm	v_2 in mm	v_3 in mm	v_4 in mm	u in mm			y-y in ⁴ cm ⁴	z-z in ⁴ cm ⁴	y-y* in ³ cm ³	y-y** in ³ cm ³	z-z in ³ cm ³	Waterside ft ² /ft m ² /m	Landside ft ² /ft m ² /m	
HZ 880M A	15.99 406.2	15.64 397.2	16.54 420.1	16.19 411.2	9.02 229.0	45.32 292.4	154.24 229.5	8,441.2 351350	928.3 38640	527.9 8650	-	102.8 1685	1.57 0.478	9.73 2.966	
HZ 880M B	16.07 408.1	15.72 399.3	16.54 420.0	16.19 411.2	9.06 230.0	50.33 324.7	171.30 254.9	9,293.1 386810	991.8 41280	578.5 9480	-	109.5 1795	1.58 0.481	9.74 2.967	
HZ 880M C	16.14 409.9	15.81 401.5	16.53 419.9	16.20 411.4	9.06 230.0	52.58 339.2	178.93 266.3	9,870.2 410830	1,030.0 42870	611.8 10025	-	113.8 1865	1.58 0.481	9.74 2.967	
HZ 1080M A	20.79 528.2	20.44 519.2	21.34 542.1	20.99 533.2	8.94 227.0	57.52 371.1	195.75 291.3	16,729.6 696340	913.7 38030	804.6 13185	-	102.2 1675	1.55 0.473	11.14 3.396	
HZ 1080M B	20.92 531.4	20.55 522.0	21.35 542.3	20.98 533.0	8.94 227.0	61.09 394.1	207.89 309.4	18,273.4 760600	981.9 40870	873.6 14315	-	109.8 1800	1.56 0.475	11.14 3.396	
HZ 1080M C	21.02 533.9	20.69 525.5	21.33 541.9	21.00 533.4	8.98 228.0	67.60 436.1	230.05 342.4	20,157.5 839020	1,045.1 43500	959.0 15715	-	116.6 1910	1.56 0.475	11.15 3.397	
HZ 1080M D	21.17 537.6	20.86 529.8	21.32 541.6	21.01 533.7	9.00 228.5	72.87 470.1	247.99 369.0	21,993.0 915420	1,038.9 45480	1,038.9 17025	-	121.4 1990	1.56 0.475	11.15 3.397	
HZ 1180M A	21.32 541.4	21.02 534.0	21.32 541.6	21.02 534.0	9.02 229.0	77.09 497.3	262.34 390.4	23,377.3 973040	1,116.4 46470	1,096.6 17970	-	123.9 2030	1.57 0.477	11.15 3.397	
HZ 1180M B	21.44 544.5	21.06 534.9	21.44 544.5	21.06 534.9	9.02 229.0	79.75 514.5	271.39 403.9	24,572.3 1022780	1,181.5 49180	1,146.3 18785	-	131.2 2150	1.58 0.481	11.18 3.407	
HZ 1180M C	21.51 546.3	21.15 537.1	21.51 546.3	21.15 537.1	9.04 229.5	84.26 543.6	286.77 426.8	26,111.3 1086840	1,267.3 52750	1,214.1 19895	-	140.4 2300	1.58 0.481	11.21 3.416	
HZ 1180M D	21.67 550.4	21.14 537.0	21.67 550.4	21.14 537.0	9.06 230.0	88.42 570.5	300.92 447.8	27,494.2 1144400	1,329.8 55350	1,269.0 20795	-	146.8 2405	1.60 0.487	11.24 3.419	

* Referring outside of HZM-flange. ** Referring outside of connector.

Solution 104

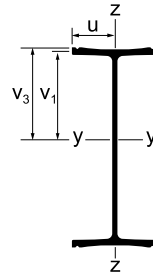

SECTION	PROPERTIES PER SOLUTION												Coating Area	
	Dimensions					Sectional Area	Mass	Moment of Inertia		Elastic Section Modulus				
	v ₁ in mm	v ₂ in mm	v ₃ in mm	v ₄ in mm	u in mm			y-y in ⁴ cm ⁴	z-z in ⁴ cm ⁴	y-y* in ³ cm ³	y-y** in ³ cm ³	z-z in ³ cm ³	Waterside ft ² /ft m ² /m	Landside ft ² /ft m ² /m
HZ 880M A	15.82 401.7	-	16.36 415.7	-	9.02 229.0	44.83 289.2	152.57 227.0	8,313.6 346040	895.9 37290	525.7 8615	-	99.5 1630	1.57 0.478	9.79 2.984
HZ 880M B	15.89 403.7	-	16.36 415.7	-	9.06 230.0	49.80 321.3	169.47 252.2	9,153.8 381010	956.2 39800	576.1 9440	-	105.6 1730	1.58 0.481	9.80 2.987
HZ 880M C	15.97 405.7	-	16.39 415.7	-	9.06 230.0	52.04 335.7	177.01 263.6	9,730.8 405030	994.2 41380	609.3 9985	-	109.8 1800	1.58 0.480	9.80 2.987
HZ 1080M A	20.62 523.7	-	21.17 537.7	-	8.94 227.0	57.04 368.0	194.10 288.9	16,518.6 687560	882.4 36730	801.2 13130	-	98.9 1620	1.55 0.473	11.20 3.414
HZ 1080M B	20.74 526.7	-	21.17 537.7	-	8.94 227.0	60.55 390.6	206.06 306.7	18,038.5 750820	947.3 39430	869.9 14255	-	105.9 1735	1.56 0.475	11.20 3.415
HZ 1080M C	20.85 529.7	-	21.17 537.7	-	8.98 228.0	67.06 432.7	228.22 339.6	19,922.3 829230	1,010.3 42050	955.3 15655	-	112.6 1845	1.56 0.476	11.21 3.417
HZ 1080M D	21.01 533.7	-	21.17 537.7	-	9.00 228.5	72.33 466.7	246.16 366.3	21,757.8 905630	1,057.6 44020	1,035.6 16970	-	117.5 1925	1.56 0.477	11.21 3.417
HZ 1180M A	21.17 537.7	-	21.17 537.7	-	9.02 229.0	76.54 493.8	260.49 387.7	23,139.9 963160	1,080.9 44990	1,093.2 17915	-	119.9 1965	1.57 0.477	11.21 3.418
HZ 1180M B	21.25 539.7	-	21.25 539.7	-	9.02 229.0	79.03 509.8	268.94 400.2	24,256.4 1009630	1,134.5 47220	1,141.5 18705	-	125.7 2060	1.58 0.481	11.25 3.430
HZ 1180M C	21.33 541.7	-	21.33 541.7	-	9.04 229.5	83.55 539.0	284.32 423.1	25,793.0 1073590	1,220.0 50780	1,209.5 19820	-	134.9 2210	1.58 0.482	11.28 3.439
HZ 1180M D	21.41 543.7	-	21.41 543.7	-	9.06 230.0	87.33 563.4	297.20 442.3	27,009.1 1124210	1,257.7 52350	1,261.7 20675	-	138.8 2275	1.60 0.487	11.29 3.440

* Referring outside of HZM-flange. ** Referring outside of connector.

Solution 12

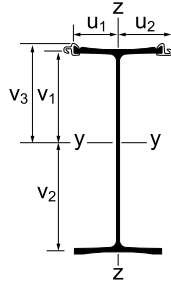

Delivery Form

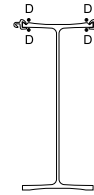

D = discontinuous weld, a = 0.236" (6 mm), 10% of length (3.94" per 3.28'; 100 mm/m) over the whole pile length + 19.68" (500 mm) continuous weld at top and toe

R = continuous weld, a = 0.236" (6 mm), length 19.68" (500 mm) at top and toe only

SECTION	PROPERTIES PER SOLUTION														Coating Area	
	Dimensions						Sectional Area	Mass	Moment of Inertia		Elastic Section Modulus					
	v ₁	v ₂	v ₃	v ₄	u ₁	u ₂			y-y	z-z	y-y*	y-y**	z-z	Waterside	Landside	
in mm	in mm	in mm	in mm	in mm	in mm	in ² cm ²	lb/ft kg/m	in ⁴ cm ⁴	in ⁴ cm ⁴	in ³ cm ³	in ³ cm ³	in ³ cm ³	ft ² /ft m ² /m	ft ² /ft m ² /m		
HZ 880M A	14.02 356.2	17.61 447.2	15.37 390.5	-	9.01 228.9	11.14 282.9	51.70 333.5	175.93 261.8	9,868.7 410770	1,504.9 62640	560.5 9185	642.0 10520	135.2 2215	2.04 0.621	9.90 3.017	
HZ 880M B	14.27 362.5	17.51 444.9	15.55 394.9	-	9.05 229.9	11.18 283.9	56.71 365.8	192.98 287.2	10,738.2 446960	1,573.2 65480	613.0 10045	690.8 11320	140.7 2305	2.05 0.624	9.91 3.019	
HZ 880M C	14.41 366.1	17.53 445.3	15.61 396.4	-	9.05 229.9	11.18 283.9	58.95 380.3	200.61 298.5	11,320.8 471210	1,611.1 67060	645.3 10580	725.3 11885	144.0 2360	2.05 0.624	9.90 3.019	
HZ 1080M A	18.72 475.6	22.51 571.8	20.07 509.9	-	8.93 226.9	11.06 280.9	63.89 412.2	217.43 323.6	19,207.5 799480	1,480.7 61630	853.1 13980	956.9 15680	133.9 2195	2.02 0.617	11.31 3.447	
HZ 1080M B	18.96 481.5	22.51 571.9	20.19 512.9	-	8.93 226.9	11.06 280.9	67.46 435.2	229.58 341.6	20,767.9 864430	1,548.9 64470	922.4 15115	1,028.6 16855	140.1 2295	2.03 0.618	11.31 3.447	
HZ 1080M C	19.23 488.5	22.48 570.9	20.35 516.8	-	8.97 227.9	11.10 281.9	73.97 477.2	251.74 374.6	22,670.7 943630	1,616.9 67300	1,008.7 16530	1,114.3 18260	145.3 2390	2.03 0.619	11.32 3.449	
HZ 1080M D	19.50 495.3	22.53 572.1	20.46 519.6	-	8.99 228.4	11.12 282.4	79.24 511.2	269.67 401.3	24,519.0 1020560	1,666.9 69380	1,088.7 17840	1,198.8 19645	149.8 2455	2.03 0.620	11.32 3.449	
HZ 1180M A	19.73 501.2	22.61 574.2	20.53 521.5	-	9.01 228.9	11.14 282.9	83.46 538.4	284.02 422.7	25,912.4 1078560	1,693.0 70470	1,146.3 18785	1,262.0 20680	151.9 2490	2.04 0.621	11.32 3.449	
HZ 1180M B	19.90 505.5	22.60 573.9	20.62 523.8	-	9.01 228.9	11.14 282.9	86.12 555.6	293.07 436.1	27,124.2 1129000	1,758.1 73180	1,200.3 19670	1,315.4 21555	157.7 2585	2.04 0.622	11.33 3.454	
HZ 1180M C	19.90 505.5	22.75 577.9	20.66 524.8	-	9.03 229.4	11.16 283.4	91.33 589.2	310.81 462.5	28,917.9 1203660	1,897.5 78980	1,271.1 20830	1,399.6 22935	170.0 2785	2.08 0.635	11.36 3.463	
HZ 1180M D	20.13 511.2	22.68 576.2	20.81 528.5	-	9.05 229.9	11.18 283.9	95.49 616.1	324.96 483.6	30,333.2 1262570	1,962.6 81690	1,337.3 21915	1,457.9 23890	175.4 2875	2.10 0.641	11.38 3.468	

* Referring outside of HZM-flange. ** Referring outside of connector.

Solution 14

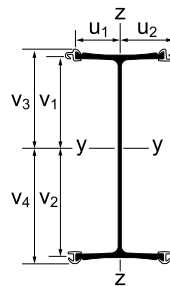

Delivery Form

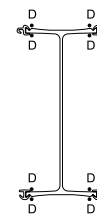

D = discontinuous weld, a = 0.236" (6 mm), 10% of length (3.94" per 3.28', 100 mm/m) over the whole pile length + 19.68" (500 mm) continuous weld at top and toe

R = continuous weld, a = 0.236" (6 mm), length 19.68" (500 mm) at top and toe only

SECTION	PROPERTIES PER SOLUTION														Coating Area	
	Dimensions						Sectional Area	Mass	Moment of Inertia		Elastic Section Modulus					
	v ₁	v ₂	v ₃	v ₄	u ₁	u ₂			y-y	z-z	y-y*	y-y**	z-z	Waterside	Landside	
in	in	in	in	in	in	in ²	lb/ft	in ⁴	in ⁴	in ³	in ³	in ³	ft ² /ft	ft ² /ft		
	mm	mm	mm	mm	mm	cm ²	kg/m	cm ⁴	cm ⁴	cm ³	cm ³	cm ³	m ² /m	m ² /m		
HZ 880M A	15.79 401.1	15.84 402.4	17.14 435.4	17.20 436.8	9.01 228.9	11.14 282.9	57.44 370.6	195.49 290.9	11,485.9 478080	2,013.5 83810	725.0 11880	667.9 10945	180.9 2965	2.04 0.621	10.67 3.253	
HZ 880M B	15.87 403.1	15.92 404.3	17.14 435.4	17.19 436.8	9.05 229.9	11.18 283.9	62.41 402.6	212.38 316.1	12,326.0 513050	2,083.2 86710	774.4 12690	716.7 11745	186.4 3055	2.05 0.624	10.68 3.256	
HZ 880M C	15.95 405.1	16.00 406.3	17.14 435.5	17.19 436.7	9.05 229.9	11.18 283.9	64.65 417.1	220.02 327.4	12,903.21 537070	2,121.3 88290	806.7 13220	750.6 12300	189.8 3110	2.05 0.624	10.68 3.255	
HZ 1080M A	20.59 522.9	20.65 524.5	21.94 557.3	22.00 558.9	8.93 226.9	11.06 280.9	69.65 449.3	237.02 352.7	21,900.5 911570	1,981.6 82480	1,060.6 17380	995.3 16310	179.1 2935	2.02 0.617	12.08 3.683	
HZ 1080M B	20.71 526.0	20.77 527.4	21.94 557.3	22.00 558.9	8.93 226.9	11.06 280.9	73.16 472.0	248.98 370.5	23,420.1 974820	2,046.4 85180	1,128.0 18485	1,064.6 17445	185.2 3035	2.03 0.618	12.09 3.684	
HZ 1080M C	20.83 529.0	20.88 530.4	21.94 557.3	22.00 558.9	8.97 227.9	11.10 281.9	79.67 514.0	271.14 403.5	25,304.3 1053250	2,118.5 88180	1,211.9 19860	1,150.3 18850	191.0 3130	2.03 0.619	12.09 3.685	
HZ 1080M D	20.99 533.1	21.04 534.3	21.94 557.3	22.00 558.9	8.99 228.4	11.12 282.4	84.94 548.0	289.07 430.2	27,139.6 1129640	2,170.7 90350	1,290.0 21140	1,233.6 20215	195.3 3200	2.03 0.620	12.09 3.686	
HZ 1180M A	21.15 537.1	21.19 538.3	21.95 557.4	22.00 558.9	9.01 228.9	11.14 282.9	89.15 575.2	303.41 451.5	28,521.8 1187170	2,198.5 91510	1,345.9 22055	1,296.8 21250	197.4 3235	2.04 0.621	12.10 3.687	
HZ 1180M B	21.22 539.1	21.27 540.3	21.95 557.4	22.00 558.9	9.01 228.9	11.14 282.8	91.64 591.2	311.86 464.1	29,638.2 1233640	2,252.1 93740	1,393.5 22835	1,347.4 22080	202.3 3315	2.04 0.622	12.10 3.688	
HZ 1180M C	21.49 545.9	21.16 537.5	22.25 565.2	21.92 556.8	9.03 229.4	11.16 283.4	98.44 635.1	334.99 498.5	32,120.9 1336980	2,538.7 105670	1,494.5 24490	1,443.5 23655	227.6 3730	2.08 0.635	12.21 3.722	
HZ 1180M D	21.57 547.8	21.25 539.6	22.25 565.1	21.93 556.9	9.05 229.9	11.18 283.9	102.22 659.5	347.87 517.7	33,337.1 1387600	2,582.2 107480	1,546.0 25335	1,498.4 24555	231.0 3785	2.10 0.641	12.23 3.728	

* Referring outside of HZM-flange. ** Referring outside of connector.

Solution 24

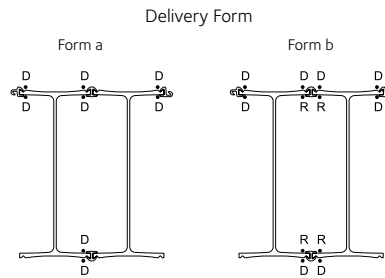
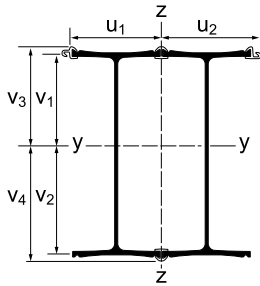

D = discontinuous weld, a = 0.236" (6 mm), 10% of length (3.94" per 3.28', 100 mm/m) over the whole pile length + 19.68" (500 mm) continuous weld at top and toe

R = continuous weld, a = 0.236" (6 mm), length 19.68" (500 mm) at top and toe only

SECTION	PROPERTIES PER SOLUTION														
	Dimensions						Sectional Area	Mass	Moment of Inertia		Elastic Section Modulus			Coating Area	
	v ₁	v ₂	v ₃	v ₄	u ₁	u ₂			y-y	z-z	y-y*	y-y**	z-z	Waterside	Landside
in mm	in mm	in mm	in mm	in mm	in mm	in ² cm ²	lb/ft kg/m	in ⁴ cm ⁴	in ⁴ cm ⁴	in ³ cm ³	in ³ cm ³	in ³ cm ³	ft ² /ft m ² /m	ft ² /ft m ² /m	
HZ 880M A	14.83 376.7	16.80 426.7	16.19 411.2	18.16 461.2	18.30 464.8	20.43 518.9	102.27 659.8	348.05 518.0	19,700.5 820000	11,783.3 490460	1,172.9 19220	1,085.0 17780	576.7 9450	3.75 1.144	11.68 3.559
HZ 880M B	15.00 380.9	16.79 426.5	16.27 413.4	18.07 458.9	18.38 466.9	20.51 520.9	112.20 723.9	381.85 568.3	21,389.7 890310	12,853.1 534990	1,273.9 20875	1,183.9 19400	626.7 10270	3.77 1.150	11.70 3.565
HZ 880M C	15.11 383.8	16.83 427.6	16.31 414.3	18.03 458.1	18.38 466.9	20.51 520.9	116.69 752.8	397.12 591.0	22,547.0 938480	13,319.7 554410	1,339.5 21950	1,250.4 20490	649.6 10645	3.77 1.150	11.69 3.565
HZ 1080M A	19.58 497.4	21.65 550.0	20.94 531.8	23.01 584.4	18.14 460.9	20.27 514.9	126.68 817.3	431.12 641.6	38,283.1 1593470	13,659.9 568570	1,767.9 28970	1,663.8 27265	674.0 11045	3.73 1.136	13.07 3.985
HZ 1080M B	19.75 501.8	21.72 551.6	20.99 533.2	22.95 583.1	18.14 460.9	20.27 514.9	133.71 862.6	455.04 677.2	41,329.7 1720280	14,385.9 598790	1,903.0 31185	1,800.5 29505	709.7 11630	3.73 1.138	13.08 3.987
HZ 1080M C	19.96 507.0	21.75 552.4	21.08 535.4	22.87 580.8	18.22 462.9	20.35 516.9	146.73 946.7	499.36 743.1	45,109.3 1877600	15,733.3 654870	2,074.2 33990	1,972.6 32325	773.2 12670	3.74 1.141	13.09 3.990
HZ 1080M D	20.18 512.5	21.85 554.9	21.14 536.9	22.81 579.3	18.26 463.9	20.39 517.9	157.27 1014.7	535.23 796.5	48,787.8 2030710	16,792.3 698950	2,233.2 36595	2,139.2 35055	823.5 13495	3.75 1.142	13.10 3.991
HZ 1180M A	20.38 517.6	21.96 557.8	21.18 538.0	22.77 578.2	18.30 464.9	20.43 518.9	165.70 1069.0	563.90 839.2	51,557.9 2146010	17,628.8 733770	2,347.6 38470	2,264.9 37115	862.9 14140	3.75 1.144	13.10 3.993
HZ 1180M B	20.48 520.2	22.02 559.2	21.20 538.6	22.74 577.7	18.30 464.9	20.43 518.9	170.66 1101.0	580.80 864.3	53,793.9 2239080	18,164.3 756060	2,443.4 40040	2,365.3 38760	889.1 14570	3.76 1.147	13.13 4.002
HZ 1180M C	20.53 521.4	22.12 562.0	21.29 540.7	22.88 581.3	18.38 466.9	20.51 520.9	181.98 1174.1	619.31 921.6	57,800.8 2405860	19,543.1 813450	2,612.4 42810	2,525.8 41390	952.9 15615	3.82 1.164	13.17 4.015
HZ 1180M D	20.64 524.2	22.17 563.2	21.32 541.5	22.85 580.5	18.42 467.9	20.55 521.9	189.55 1222.9	645.07 960.0	60,237.4 2507280	20,355.4 847260	2,716.8 44520	2,635.9 43195	990.7 16235	3.86 1.176	13.20 4.025

* Referring outside of HZM-flange. ** Referring outside of connector.

Solution 26

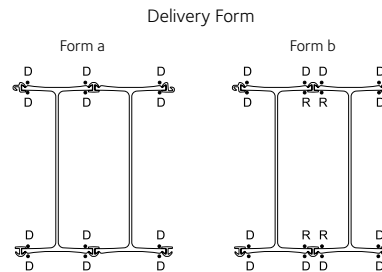
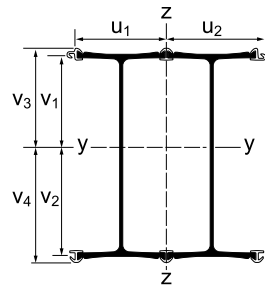

D = discontinuous weld, a = 0.236" (6 mm), 10% of length (3.94" per 3.28', 100 mm/m) over the whole pile length + 19.68" (500 mm) continuous weld at top and toe

R = continuous weld, a = 0.236" (6 mm), length 19.68" (500 mm) at top and toe only

SECTION	PROPERTIES PER SOLUTION														
	Dimensions						Sectional Area	Mass	Moment of Inertia		Elastic Section Modulus			Coating Area	
	v_1	v_2	v_3	v_4	u_1	u_2			y-y	z-z	y-y*	y-y**	z-z	Waterside	Landside
in mm	in mm	in mm	in mm	in mm	in mm	in ² cm ²	lb/ft kg/m	in ⁴ cm ⁴	in ⁴ cm ⁴	in ³ cm ³	in ³ cm ³	in ³ cm ³	ft ² /ft m ² /m	ft ² /ft m ² /m	
HZ 880M A	15.81 401.4	15.82 402.0	17.16 435.8	17.19 436.5	18.31 464.9	20.43 518.9	108.51 700.1	369.28 549.6	21,379.6 889890	13,940.3 580240	1,351.1 22135	1,244.0 20385	682.6 11180	3.75 1.144	12.39 3.776
HZ 880M B	15.88 403.4	15.91 404.0	17.16 435.8	17.18 436.5	18.38 466.9	20.50 520.9	118.44 764.1	403.08 599.9	23,059.9 959830	15,028.4 625530	1,449.6 23755	1,341.9 21990	732.9 12010	3.77 1.150	12.41 3.782
HZ 880M C	15.96 405.4	15.98 406.0	17.16 435.9	17.18 436.5	18.38 466.9	20.50 520.9	122.93 793.1	418.35 622.6	24,213.8 1007860	15,494.9 644950	1,514.9 24825	1,409.0 23090	755.8 12380	3.77 1.150	12.41 3.782
HZ 1080M A	20.60 523.3	20.63 524.1	21.96 557.7	21.99 558.5	18.14 460.9	20.27 514.9	132.92 857.6	452.36 673.2	41,095.0 1710510	15,780.3 656830	1,991.5 32635	1,868.9 30625	778.4 12755	3.73 1.136	13.79 4.202
HZ 1080M B	20.72 526.3	20.75 527.1	21.96 557.7	21.99 558.5	18.14 460.9	20.27 514.9	139.95 902.9	476.27 708.8	44,134.6 1837030	16,506.6 687060	2,127.0 34855	2,007.1 32890	814.4 13345	3.73 1.138	13.79 4.204
HZ 1080M C	20.84 529.4	20.87 530.1	21.96 557.8	21.99 558.5	18.22 462.9	20.35 516.9	152.97 986.9	520.59 774.7	47,902.7 1993870	17,872.2 743900	2,295.4 37615	2,178.6 35700	878.4 14395	3.74 1.141	13.80 4.208
HZ 1080M D	21.00 533.4	21.02 534.0	21.96 557.8	21.99 558.5	18.26 463.9	20.39 517.9	163.51 1054.9	556.46 828.1	51,573.5 2146660	18,940.1 788350	2,452.9 40195	2,345.8 38440	929.1 15225	3.75 1.142	13.81 4.209
HZ 1180M A	21.16 537.4	21.18 538.0	21.96 557.8	21.99 558.4	18.30 464.9	20.43 518.9	171.94 1109.3	585.13 870.8	54,338.1 2261730	19,785.8 823550	2,565.4 42040	2,471.5 40500	968.8 15875	3.75 1.144	13.81 4.210
HZ 1180M B	21.24 539.4	21.26 540.0	21.96 557.8	21.99 558.4	18.30 464.9	20.43 518.8	176.90 1141.3	602.03 895.9	56,570.9 2354670	20,321.3 845840	2,661.0 43605	2,573.1 42165	995.0 16305	3.76 1.147	13.82 4.213
HZ 1180M C	21.41 543.9	21.24 539.5	22.17 563.2	22.00 558.8	18.38 466.9	20.51 520.9	189.81 1224.5	645.94 961.3	61,256.8 2549710	22,283.7 927520	2,860.8 46880	2,762.9 45275	1,086.5 17805	3.82 1.164	13.95 4.251
HZ 1180M D	21.49 545.8	21.32 541.6	22.17 563.1	22.00 558.9	18.42 467.9	20.55 521.9	197.37 1273.4	671.70 999.6	63,689.1 2650950	23,107.5 961810	2,963.9 48570	2,873.0 47080	1,124.7 18430	3.86 1.176	13.99 4.264

* Referring outside of HZM-flange. ** Referring outside of connector.

AZ - Intermediary Piles

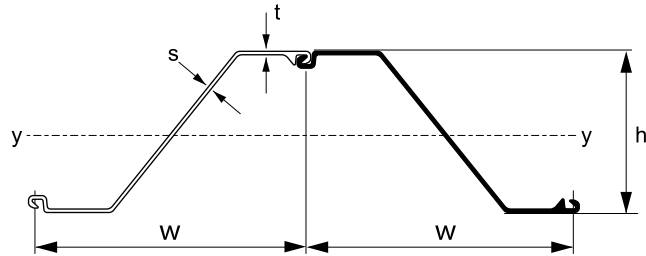

SECTION	Dimensions				PROPERTIES PER SOLUTION					
					Sectional Area (per double) in ² cm ²	Mass lb/ft kg/m	Moment of Inertia	Elastic Section Modulus	Radius of Gyration	Coating Area
	y-y in ⁴ cm ⁴	y-y in ³ cm ³	y-y in cm	ft ² /ft m ² /m						
AZ 14-770	30.31 345	13.56 1540	0.375 9.5	0.375 9.5	31.40 202.6	106.84 159.0	862.2 35890	127.2 2085	5.24 13.31	6.10 1.85
AZ 19-700	27.56 421	16.56 1400	0.375 9.5	0.375 9.5	31.59 203.8	107.52 160.0	1,324.5 55130	159.8 2620	6.47 16.44	6.10 1.86
AZ 26-700	27.56 460	18.11 1400	0.480 12.2	0.480 12.2	40.63 262.1	138.24 205.7	2,008.7 83610	221.8 3635	7.03 17.86	6.33 1.93

Connectors

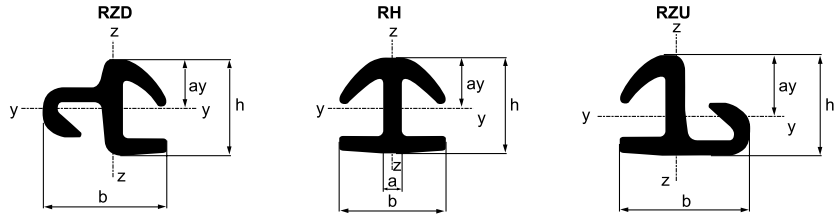

SECTION	Dimensions				Suitable King Pile	Sectional Area	Mass	Moment of Inertia		Elastic Section Modulus		Coated Area	
	h in mm	b in mm	a in mm	ay in mm				y-y in ⁴ cm ⁴	z-z in ⁴ cm ⁴	y-y in ³ cm ³	z-z in ³ cm ³	Waterside ft ² /ft m ² /m	Landside ft ² /ft m ² /m
RZD 16	2.43 61.8	3.19 80.5	-	1.24 31.5	HZ 880M / 1080M / 1180M A-B	3.21 20.7	10.89 16.2	1.4 57	2.3 94	1.1 18	1.3 22	0.39 0.12	0.20 0.06
RZU 16	2.43 61.8	3.19 80.5	-	1.51 38.3	HZ 880M / 1080M / 1180M A-B	3.16 20.4	10.82 16.1	1.6 68	2.3 94	1.1 18	1.3 22	0.26 0.08	0.33 0.10
RH 16	2.43 61.8	2.69 68.2	0.48 12.2	1.28 32.5	HZ 880M / 1080M / 1180M A-B	3.12 20.1	10.75 16.0	2.0 83	1.3 54	1.5 25	1.0 16	0.33 0.10	0.30 0.09
RZD 18	2.65 67.3	3.35 85.0	-	1.41 35.9	HZ 1180M C-D	3.57 23.0	12.16 18.1	1.9 78	2.6 110	1.3 22	1.5 25	0.39 0.12	0.23 0.07
RZU 18	2.65 67.3	3.35 85.0	-	1.66 42.1	HZ 1180M C-D	3.50 22.6	12.03 17.9	2.2 92	2.6 110	1.3 22	1.5 25	0.30 0.09	0.33 0.10
RH 20	2.65 67.3	3.12 79.2	0.56 14.2	1.44 36.5	HZ 1180M C-D	3.91 25.2	13.44 20.0	2.9 122	2.1 88	2.0 33	1.3 22	0.36 0.11	0.33 0.10

Without other specifications, all the connectors are offered in Grade S 430 GP.

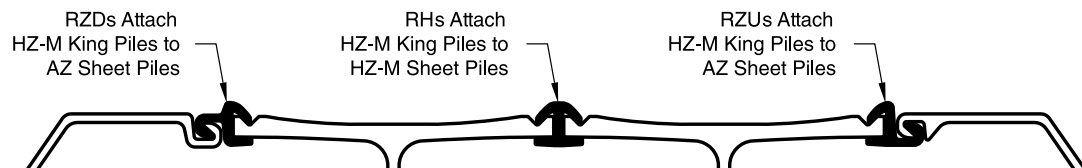

Combination HZ...M-12 / AZ 14-770

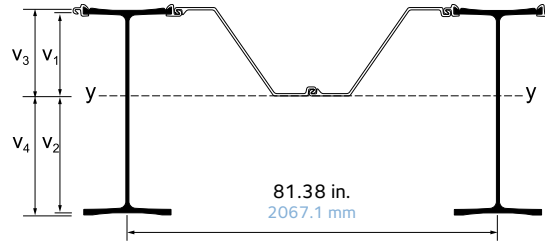

SECTION	PROPERTIES PER FOOT OF WALL				MASS OF COMBINATION WITH INTERMEDIARY SECTION				
	Sectional Area in ² /ft cm ² /m	Moment of Inertia in ⁴ /ft cm ⁴ /m	*Elastic Section Modulus in ³ /ft cm ³ /m	**Elastic Section Modulus in ³ /ft cm ³ /m	*** AZ 14-770			Coating Area	
					ℓAZ = 60% ℓHZ lb/ft ² kg/m ²	ℓAZ = 80% ℓHZ lb/ft ² kg/m ²	ℓAZ = ℓHZ lb/ft ² kg/m ²	Waterside ft ² /ft m ² /m	Landside ft ² /ft m ² /m
HZ 880M A	12.25 265.4	1,581.7 215994	89.8 4827.9	102.9 5532.2	34.10 166.49	37.89 184.99	41.68 203.50	8.09 2.466	15.95 4.862
HZ 880M B	12.97 281.0	1,708.2 233269	97.6 5247.3	109.8 5903.2	36.58 178.60	40.37 197.10	44.15 215.56	8.10 2.469	15.96 4.865
HZ 880M C	13.30 288.2	1,794.0 244985	102.3 5500.0	114.9 6177.4	37.70 184.07	41.49 202.57	45.28 221.08	8.10 2.469	15.96 4.865
HZ 1080M A	14.07 304.9	2,963.8 404731	131.7 7080.6	147.7 7940.8	40.30 196.76	44.09 215.27	47.89 233.82	8.08 2.463	17.36 5.291
HZ 1080M B	14.60 316.3	3,194.3 436208	141.9 7629.0	158.2 8505.3	42.09 205.50	45.89 224.05	49.68 242.56	8.08 2.463	17.36 5.291
HZ 1080M C	15.55 336.9	3,471.9 474116	154.5 8306.4	170.7 9177.4	45.32 221.27	49.11 239.77	52.91 258.33	8.08 2.463	17.37 5.294
HZ 1080M D	16.32 353.6	3,742.8 511110	166.2 8935.4	182.9 9833.3	47.94 234.06	51.73 252.57	55.52 271.07	8.09 2.466	17.37 5.294
HZ 1180M A	16.93 366.8	3,946.4 538913	174.6 9387.0	192.2 10333.3	50.03 244.27	53.82 262.77	57.61 281.28	8.09 2.466	17.37 5.294
HZ 1180M B	17.32 375.3	4,125.0 563303	182.6 9817.1	200.0 10752.6	51.37 250.81	55.16 269.31	58.95 287.82	8.09 2.466	17.39 5.300
HZ 1180M C	18.08 391.7	4,387.2 599108	192.9 10370.9	212.3 11413.9	53.82 262.77	57.67 281.57	61.53 300.41	8.14 2.481	17.42 5.310
HZ 1180M D	18.68 404.7	4,593.6 627294	202.5 10887.0	220.8 11870.9	55.87 272.78	59.73 291.63	63.59 310.47	8.16 2.487	17.43 5.313

* Referring outside of HZM-flange (V₁), ** Referring outside of connector (V₂), *** Length of connectors = Length of AZ.

Combination HZ...M-14 / AZ 14-770

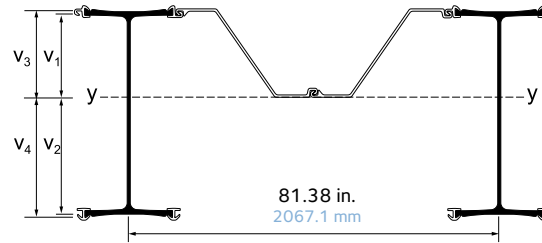

SECTION	PROPERTIES PER FOOT OF WALL				MASS OF COMBINATION WITH INTERMEDIARY SECTION				
	Sectional Area in ² /ft cm ² /m	Moment of Inertia in ⁴ /ft cm ⁴ /m	*Elastic Section Modulus in ³ /ft cm ³ /m	**Elastic Section Modulus in ³ /ft cm ³ /m	*** AZ 14-770			Coating Area	
					ℓAZ = 60% ℓHZ lb/ft ² kg/m ²	ℓAZ = 80% ℓHZ lb/ft ² kg/m ²	ℓAZ = ℓHZ lb/ft ² kg/m ²	Waterside ft ² /ft m ² /m	Landside ft ² /ft m ² /m
HZ 880M A	13.09 283.6	1,820.1 248550	114.9 6177.4	105.8 5688.1	35.73 174.45	40.15 196.03	44.56 217.56	8.09 2.466	16.72 5.096
HZ 880M B	13.81 299.2	1,942.0 265196	122.0 6559.1	112.9 6069.9	38.19 186.46	42.60 208.00	47.01 229.52	8.10 2.469	16.73 5.099
HZ 880M C	14.14 306.4	2,026.9 276790	126.8 6817.2	117.9 6338.7	39.31 191.93	43.72 213.46	48.13 234.99	8.10 2.469	16.73 5.099
HZ 1080M A	14.92 323.3	3,361.5 459040	162.8 8752.6	152.8 8215.0	41.94 204.77	46.36 226.35	50.78 247.93	8.08 2.463	18.14 5.529
HZ 1080M B	15.44 334.5	3,586.0 489698	172.7 9284.9	162.9 8758.0	43.70 213.36	48.13 234.99	52.55 256.57	8.08 2.463	18.14 5.529
HZ 1080M C	16.39 355.1	3,860.5 527183	184.9 9940.8	175.5 9435.4	46.93 229.13	51.35 250.71	55.77 272.29	8.08 2.463	18.14 5.529
HZ 1080M D	17.16 371.8	4,129.2 563876	196.3 10553.7	187.7 10091.3	49.55 241.92	53.97 263.50	58.39 285.08	8.09 2.466	18.15 5.532
HZ 1180M A	17.77 385.0	4,331.0 591434	204.3 10983.8	196.9 10586.0	51.64 252.13	56.06 273.71	60.47 295.24	8.09 2.466	18.15 5.532
HZ 1180M B	18.13 392.8	4,495.5 613897	211.3 11360.1	204.4 10989.2	52.88 258.18	57.30 279.76	61.72 301.34	8.09 2.466	18.15 5.532
HZ 1180M C	19.13 414.5	4,859.1 663550	226.1 12155.8	218.4 11741.9	55.81 272.49	60.45 295.14	65.09 317.80	8.14 2.481	18.27 5.569
HZ 1180M D	19.68 426.4	5,035.9 687693	233.5 12553.7	226.4 12172.0	57.68 281.62	62.32 304.27	66.96 326.93	8.16 2.487	18.29 5.575

* Referring outside of HZM-flange (highest value of v₁; v₂), ** Referring outside of connector (highest value of v₃; v₄), *** Length of connectors = Length of AZ.

Combination HZ...M-24 / AZ 14-770

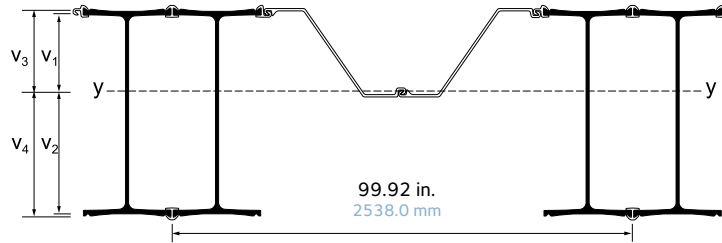

SECTION	PROPERTIES PER FOOT OF WALL				MASS OF COMBINATION WITH INTERMEDIARY SECTION				
	Sectional Area in ² /ft cm ² /m	Moment of Inertia in ⁴ /ft cm ⁴ /m	*Elastic Section Modulus in ³ /ft cm ³ /m	**Elastic Section Modulus in ³ /ft cm ³ /m	*** AZ 14-770			Coating Area	
					ℓAZ = 60% ℓHZ lb/ft ² kg/m ²	ℓAZ = 80% ℓHZ lb/ft ² kg/m ²	ℓAZ = ℓHZ lb/ft ² kg/m ²	Waterside ft ² /ft m ² /m	Landside ft ² /ft m ² /m
HZ 880M A	16.04 347.5	2,467.6 336971	146.8 7892.4	135.9 7306.4	48.42 236.41	51.51 251.49	54.59 266.53	9.81 2.990	17.73 5.404
HZ 880M B	17.21 372.9	2,666.1 364078	158.8 8537.6	147.6 7935.4	52.39 255.79	55.47 270.83	58.55 285.86	9.83 2.996	17.75 5.410
HZ 880M C	17.74 384.4	2,804.8 383018	166.6 8956.9	155.5 8360.2	54.22 264.72	57.30 279.76	60.38 294.80	9.83 2.996	17.75 5.410
HZ 1080M A	19.03 412.3	4,712.4 643517	217.6 11698.9	204.8 11010.7	58.57 285.96	61.67 301.10	54.76 267.36	9.78 2.981	19.13 5.831
HZ 1080M B	19.88 430.7	5,079.2 693606	233.9 12575.2	221.2 11892.4	61.45 300.02	64.55 315.16	67.64 330.25	9.79 2.984	19.14 5.834
HZ 1080M C	21.41 463.9	5,525.4 754539	254.1 13661.2	241.6 12989.2	66.68 325.56	69.77 340.65	72.86 355.73	9.80 2.987	19.15 5.837
HZ 1080M D	22.66 491.0	5,962.8 814269	273.0 14677.3	261.4 14053.7	70.94 346.36	74.02 361.40	77.11 376.48	9.80 2.987	19.15 5.837
HZ 1180M A	23.65 512.4	6,290.6 859033	286.4 15397.8	276.3 14854.7	74.32 362.86	77.41 377.95	80.49 392.98	9.81 2.990	19.15 5.837
HZ 1180M B	24.25 525.4	6,558.9 895672	297.9 16016.0	288.4 15505.3	76.35 372.77	79.43 387.81	82.52 402.90	9.82 2.993	19.18 5.846
HZ 1180M C	25.57 554.0	7,028.7 959827	317.7 17080.5	307.1 16510.6	80.73 394.16	83.87 409.49	87.00 424.77	9.87 3.008	19.23 5.861
HZ 1180M D	26.45 573.1	7,314.9 998910	329.9 17736.4	320.1 17209.6	83.75 408.90	86.89 424.23	90.02 439.51	9.91 3.021	19.26 5.870

* Referring outside of HZM-flange (highest value of v₁; v₂), ** Referring outside of connector (highest value of v₃; v₄), *** Length of connectors = Length of AZ.

Combination HZ...M-26 / AZ 14-770

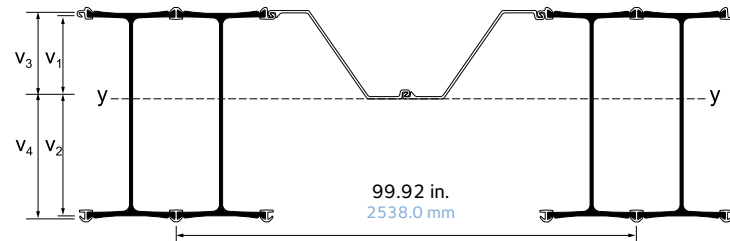

SECTION	PROPERTIES PER FOOT OF WALL				MASS OF COMBINATION WITH INTERMEDIARY SECTION				
	Sectional Area in ² /ft cm ² /m	Moment of Inertia in ⁴ /ft cm ⁴ /m	*Elastic Section Modulus in ³ /ft cm ³ /m	**Elastic Section Modulus in ³ /ft cm ³ /m	*** AZ 14-770			Coating Area	
					ℓAZ = 60% ℓHZ lb/ft ² kg/m ²	ℓAZ = 80% ℓHZ lb/ft ² kg/m ²	ℓAZ = ℓHZ lb/ft ² kg/m ²	Waterside ft ² /ft m ² /m	Landside ft ² /ft m ² /m
HZ 880M A	16.79 363.8	2,669.1 364487	168.6 9064.5	155.3 8349.4	49.95 243.88	53.54 261.40	57.14 278.98	9.81 2.990	18.44 5.621
HZ 880M B	17.95 388.9	2,866.2 391403	180.2 9688.1	166.7 8962.3	53.92 263.26	57.51 280.79	61.10 298.31	9.83 2.996	18.46 5.627
HZ 880M C	18.49 400.6	3,004.5 410289	188.0 10107.5	174.8 9397.8	55.75 272.19	59.34 289.72	62.93 307.25	9.83 2.996	18.46 5.627
HZ 1080M A	19.78 428.6	5,050.9 689741	244.8 13161.2	229.7 12349.4	60.11 293.48	63.71 311.06	67.32 328.68	9.78 2.981	19.84 6.047
HZ 1080M B	20.63 447.0	5,416.8 739708	261.1 14037.5	246.4 13247.2	62.99 307.54	66.59 325.12	70.20 342.74	9.79 2.984	19.85 6.050
HZ 1080M C	22.16 480.1	5,861.1 800381	280.9 15102.1	266.5 14327.9	68.21 333.03	71.81 350.61	75.41 368.18	9.80 2.987	19.86 6.053
HZ 1080M D	23.41 507.2	6,297.4 859962	299.6 16107.4	286.4 15397.8	72.47 353.83	76.06 371.36	79.66 388.93	9.80 2.987	19.86 6.053
HZ 1180M A	24.40 528.7	6,624.2 904589	312.8 16817.1	301.3 16198.8	75.85 370.33	79.45 387.91	83.04 405.43	9.81 2.990	19.87 6.056
HZ 1180M B	25.00 541.7	6,892.1 941173	324.2 17430.0	313.5 16854.7	77.88 380.24	81.47 397.77	85.07 415.35	9.82 2.993	19.88 6.059
HZ 1180M C	26.50 574.2	7,442.7 1016362	347.5 18682.7	335.6 18042.9	82.64 403.48	86.42 421.94	90.19 440.34	9.87 3.008	20.00 6.096
HZ 1180M D	27.39 593.5	7,728.1 1055335	359.6 19333.2	348.6 18741.8	85.66 418.23	89.44 436.68	93.21 455.09	9.91 3.021	20.04 6.108

* Referring outside of HZM-flange (highest value of v_1 ; v_2), ** Referring outside of connector (highest value of v_3 ; v_4), *** Length of connectors = Length of AZ.

Combination HZ...M-12 / AZ 19-700

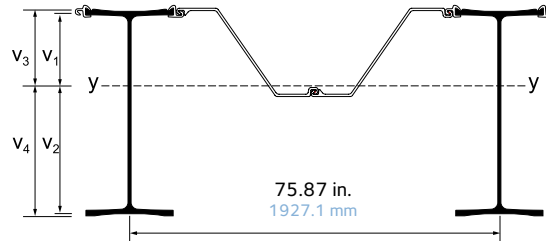

SECTION	PROPERTIES PER FOOT OF WALL				MASS OF COMBINATION WITH INTERMEDIARY SECTION				
	Sectional Area in ² /ft cm ² /m	Moment of Inertia in ⁴ /ft cm ⁴ /m	*Elastic Section Modulus in ³ /ft cm ³ /m	**Elastic Section Modulus in ³ /ft cm ³ /m	*** AZ 19-700			Coating Area	
					ℓAZ = 60% ℓHZ lb/ft ² kg/m ²	ℓAZ = 80% ℓHZ lb/ft ² kg/m ²	ℓAZ = ℓHZ lb/ft ² kg/m ²	Waterside ft ² /ft m ² /m	Landside ft ² /ft m ² /m
HZ 880M A	13.17 285.4	1,769.6 241653	100.5 5403.2	115.1 6188.1	36.64 178.89	40.72 198.81	44.81 218.78	8.13 2.478	15.99 4.874
HZ 880M B	13.94 302.0	1,905.1 260157	108.8 5849.4	122.6 6591.4	39.29 191.83	43.37 211.75	47.45 231.67	8.14 2.481	15.99 4.874
HZ 880M C	14.30 309.8	1,997.1 272720	113.9 6123.6	128.0 6881.7	40.50 197.74	44.58 217.66	48.66 237.58	8.13 2.478	15.99 4.874
HZ 1080M A	15.13 327.8	3,252.7 444183	144.5 7768.8	162.0 8709.6	43.29 211.36	47.38 231.33	51.48 251.35	8.11 2.472	17.40 5.304
HZ 1080M B	15.69 340.0	3,500.0 477954	155.5 8360.2	173.4 9322.5	45.21 220.73	49.31 240.75	53.40 260.72	8.12 2.475	17.40 5.304
HZ 1080M C	16.71 362.1	3,797.5 518580	169.0 9086.0	186.7 10037.6	48.67 237.63	52.76 257.60	56.85 277.56	8.12 2.475	17.40 5.304
HZ 1080M D	17.53 379.8	4,087.8 558223	181.4 9752.6	199.9 10747.2	51.49 251.39	55.57 271.25	59.66 291.28	8.12 2.475	17.41 5.307
HZ 1180M A	18.19 394.1	4,306.1 588033	190.5 10241.9	209.7 11274.1	53.73 262.33	57.81 282.25	61.90 302.22	8.12 2.475	17.41 5.307
HZ 1180M B	18.61 403.2	4,497.6 614184	199.0 10698.9	218.1 11725.7	55.16 269.31	59.24 289.23	63.33 309.20	8.13 2.478	17.42 5.310
HZ 1180M C	19.42 420.8	4,778.7 652571	210.1 11295.6	231.3 12435.4	57.78 282.11	61.94 302.42	66.10 322.73	8.17 2.490	17.45 5.319
HZ 1180M D	20.07 434.9	4,999.8 682764	220.4 11849.4	240.3 12919.3	59.99 292.90	64.14 313.16	68.30 333.47	8.19 2.496	17.47 5.325

* Referring outside of HZM-flange (v₂), ** Referring outside of connector (v₃), *** Length of connectors = Length of AZ.

Combination HZ...M-14 / AZ 19-700

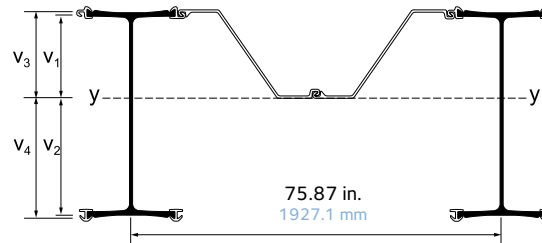

SECTION	PROPERTIES PER FOOT OF WALL				MASS OF COMBINATION WITH INTERMEDIARY SECTION				
	Sectional Area in ² /ft cm ² /m	Moment of Inertia in ⁴ /ft cm ⁴ /m	*Elastic Section Modulus in ³ /ft cm ³ /m	**Elastic Section Modulus in ³ /ft cm ³ /m	*** AZ 19-700			Coating Area	
					ℓAZ = 60% ℓHZ lb/ft ² kg/m ²	ℓAZ = 80% ℓHZ lb/ft ² kg/m ²	ℓAZ = ℓHZ lb/ft ² kg/m ²	Waterside ft ² /ft m ² /m	Landside ft ² /ft m ² /m
HZ 880M A	14.07 304.9	2,025.2 276558	127.9 6876.3	117.7 6327.9	38.39 187.44	43.14 210.63	47.90 233.87	8.13 2.478	16.76 5.108
HZ 880M B	14.84 321.5	2,155.8 294392	135.4 7279.5	125.4 6741.9	41.02 200.28	45.77 223.47	50.52 246.66	8.14 2.481	16.77 5.111
HZ 880M C	15.20 329.3	2,247.0 306846	140.4 7548.3	130.7 7026.8	42.22 206.13	46.97 229.33	51.72 252.52	8.13 2.478	16.77 5.111
HZ 1080M A	16.04 347.5	3,679.4 502452	178.2 9580.6	167.2 8989.2	45.05 219.95	49.81 243.19	54.58 266.48	8.11 2.472	18.17 5.538
HZ 1080M B	16.59 359.5	3,920.1 535322	188.8 10150.5	178.2 9580.6	46.94 229.18	51.71 252.47	56.47 275.71	8.12 2.475	18.18 5.541
HZ 1080M C	17.61 381.6	4,214.2 575484	201.8 10849.4	191.6 10301.0	50.40 246.07	55.16 269.31	59.92 292.55	8.12 2.475	18.18 5.541
HZ 1080M D	18.43 399.3	4,502.4 614840	214.0 11505.3	204.7 11005.3	53.21 259.79	57.97 283.03	62.73 306.27	8.12 2.475	18.18 5.541
HZ 1180M A	19.09 413.6	4,718.6 644364	222.6 11967.7	214.6 11537.6	55.45 270.73	60.21 293.97	64.96 317.16	8.12 2.475	18.18 5.541
HZ 1180M B	19.48 422.1	4,895.1 668466	230.1 12370.9	222.5 11962.3	56.78 277.22	61.54 300.46	66.30 323.70	8.13 2.478	18.19 5.544
HZ 1180M C	20.55 445.3	5,284.8 721683	245.9 13220.3	237.5 12768.7	59.92 292.55	64.92 316.97	69.92 341.38	8.17 2.490	18.30 5.578
HZ 1180M D	21.13 457.8	5,474.2 747547	253.8 13645.1	246.1 13231.1	61.92 302.32	66.92 326.73	71.92 351.14	8.19 2.496	18.32 5.584

* Referring outside of HZM-flange (highest value of v₁; v₂), ** Referring outside of connector (highest value of v₃; v₄), *** Length of connectors = Length of AZ.

Combination HZ...M-24 / AZ 19-700

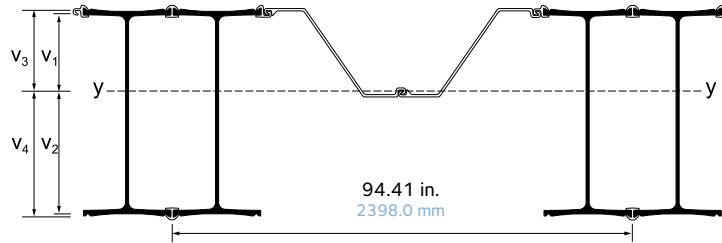

SECTION	PROPERTIES PER FOOT OF WALL				MASS OF COMBINATION WITH INTERMEDIARY SECTION				
	Sectional Area in ² /ft cm ² /m	Moment of Inertia in ⁴ /ft cm ⁴ /m	*Elastic Section Modulus in ³ /ft cm ³ /m	**Elastic Section Modulus in ³ /ft cm ³ /m	*** AZ 19-700			Coating Area	
					ℓAZ = 60% ℓHZ lb/ft ² kg/m ²	ℓAZ = 80% ℓHZ lb/ft ² kg/m ²	ℓAZ = ℓHZ lb/ft ² kg/m ²	Waterside ft ² /ft m ² /m	Landside ft ² /ft m ² /m
HZ 880M A	17.00 368.3	2,670.3 364651	158.9 8543.0	147.0 7903.2	51.29 250.42	54.57 266.43	57.86 282.50	9.84 2.999	17.77 5.416
HZ 880M B	18.23 395.0	2,880.0 393288	171.5 9220.4	159.4 8569.8	55.49 270.92	58.77 286.94	62.04 302.90	9.86 3.005	17.79 5.422
HZ 880M C	18.80 407.3	3,026.7 413321	179.8 9666.6	167.9 9026.8	57.43 280.40	60.70 296.36	63.98 312.38	9.86 3.005	17.78 5.419
HZ 1080M A	20.17 437.0	5,047.1 689223	233.1 12532.2	219.4 11795.6	62.05 302.95	65.34 319.02	68.63 335.08	9.82 2.993	19.16 5.840
HZ 1080M B	21.06 456.3	5,435.4 742248	250.3 13456.9	236.8 12731.1	65.10 317.84	68.39 333.91	71.68 349.97	9.82 2.993	19.17 5.843
HZ 1080M C	22.68 491.4	5,907.1 806663	271.6 14602.1	258.4 13892.4	70.63 344.84	73.91 360.86	77.20 376.92	9.83 2.996	19.18 5.846
HZ 1080M D	24.01 520.2	6,369.8 869848	291.6 15677.3	279.3 15016.0	75.13 366.81	78.41 382.83	81.69 398.84	9.84 2.999	19.18 5.846
HZ 1180M A	25.06 543.0	6,716.2 917152	305.8 16440.8	295.0 15860.1	78.71 384.29	81.99 400.31	85.27 416.32	9.84 2.999	19.19 5.849
HZ 1180M B	25.69 556.6	7,000.2 955935	318.0 17096.7	307.8 16548.3	80.85 394.74	84.13 410.76	87.41 426.77	9.85 3.002	19.22 5.858
HZ 1180M C	27.08 586.7	7,496.6 1023722	338.8 18214.9	327.5 17607.4	85.48 417.35	88.82 433.65	92.15 449.91	9.91 3.021	19.26 5.870
HZ 1180M D	28.01 606.9	7,799.1 1065031	351.7 18908.5	341.3 18349.3	88.67 432.92	92.01 449.23	95.34 465.49	9.95 3.033	19.29 5.880

* Referring outside of HZM-flange (highest value of v_1 ; v_2), ** Referring outside of connector (highest value of v_3 ; v_4), *** Length of connectors = Length of AZ.

Combination HZ...M-26 / AZ 19-700

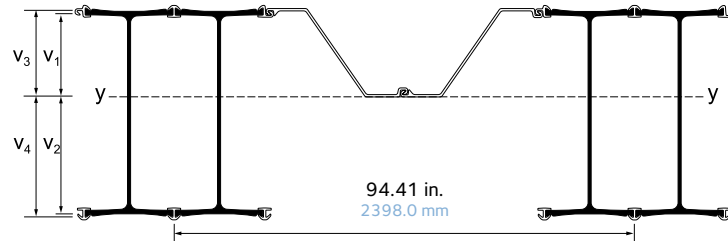

SECTION	PROPERTIES PER FOOT OF WALL				MASS OF COMBINATION WITH INTERMEDIARY SECTION				
	Sectional Area in ² /ft cm ² /m	Moment of Inertia in ⁴ /ft cm ⁴ /m	*Elastic Section Modulus in ³ /ft cm ³ /m	**Elastic Section Modulus in ³ /ft cm ³ /m	*** AZ 19-700			Coating Area	
					ℓAZ = 60% ℓHZ lb/ft ² kg/m ²	ℓAZ = 80% ℓHZ lb/ft ² kg/m ²	ℓAZ = ℓHZ lb/ft ² kg/m ²	Waterside ft ² /ft m ² /m	Landside ft ² /ft m ² /m
HZ 880M A	17.79 376.6	2,883.5 393766	182.2 9795.6	167.8 9021.4	52.91 258.33	56.73 276.98	60.55 295.63	9.84 2.999	18.48 5.633
HZ 880M B	19.02 402.6	3,091.7 422197	194.4 10451.5	180.0 9677.4	57.11 278.83	60.92 297.44	64.74 316.09	9.86 3.005	18.50 5.639
HZ 880M C	19.59 414.7	3,238.1 442189	202.6 10892.4	188.4 10129.0	59.04 288.26	62.86 306.91	66.67 325.51	9.86 3.005	18.50 5.639
HZ 1080M A	20.96 443.7	5,405.5 738165	262.0 14085.9	245.8 13215.0	63.67 310.86	67.51 329.61	71.34 348.31	9.82 2.993	19.88 6.059
HZ 1080M B	21.86 462.7	5,792.8 791054	279.2 15010.7	263.5 14166.6	66.72 325.75	70.55 344.45	74.39 363.20	9.82 2.993	19.88 6.059
HZ 1080M C	23.48 497.0	6,262.5 855196	300.1 16134.3	284.9 15317.1	72.25 352.75	76.07 371.40	79.90 390.10	9.83 2.996	19.89 6.062
HZ 1080M D	24.80 524.9	6,723.8 918190	319.8 17193.4	305.8 16440.8	76.75 374.72	80.57 393.37	84.39 412.03	9.84 2.999	19.90 6.066
HZ 1180M A	25.85 547.2	7,069.3 965371	333.8 17946.1	321.5 17284.8	80.32 392.15	84.14 410.81	87.96 429.46	9.84 2.999	19.90 6.066
HZ 1180M B	26.48 560.5	7,352.9 1004099	345.9 18596.7	334.4 17978.4	82.47 402.65	86.29 421.30	90.11 439.95	9.85 3.002	19.91 6.069
HZ 1180M C	28.07 594.1	7,934.8 1083562	370.5 19919.2	357.9 19241.8	87.51 427.26	91.52 446.84	95.53 466.42	9.91 3.021	20.04 6.108
HZ 1180M D	29.01 614.0	8,236.3 1124734	383.3 20607.4	371.5 19973.0	90.70 442.83	94.70 462.36	98.71 9743.66	9.95 3.033	20.08 6.120

* Referring outside of HZM-flange (highest value of v₁; v₂), ** Referring outside of connector (highest value of v₃; v₄), *** Length of connectors = Length of AZ.

Combination HZ...M-12 / AZ 26-700

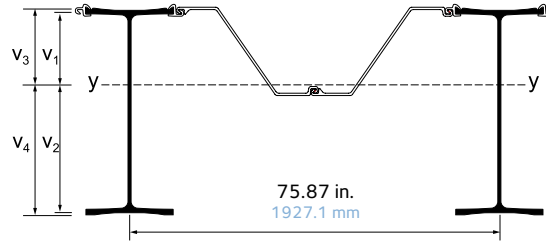

SECTION	PROPERTIES PER FOOT OF WALL				MASS OF COMBINATION WITH INTERMEDIARY SECTION				
	Sectional Area in ² /ft cm ² /m	Moment of Inertia in ⁴ /ft cm ⁴ /m	*Elastic Section Modulus in ³ /ft cm ³ /m	**Elastic Section Modulus in ³ /ft cm ³ /m	*** AZ 26-700			Coating Area	
					ℓAZ = 60% ℓHZ lb/ft ² kg/m ²	ℓAZ = 80% ℓHZ lb/ft ² kg/m ²	ℓAZ = ℓHZ lb/ft ² kg/m ²	Waterside ft ² /ft m ² /m	Landside ft ² /ft m ² /m
HZ 880M A	14.60 308.9	1,877.8 256 420	106.7 5 735	122.1 6 565	39.56 193	44.61 218	49.67 243	8.37 2.551	16.23 4.948
HZ 880M B	15.37 325.4	2,013.1 274 900	114.9 6 180	129.5 6 960	42.21 206	47.26 231	52.31 255	8.38 2.554	16.24 4.949
HZ 880M C	15.73 332.9	2,105.1 287 470	120.1 6 455	134.9 7 250	43.41 212	48.46 237	53.52 261	8.38 2.554	16.24 4.949
HZ 1080M A	16.56 350.5	3,361.2 458 990	149.3 8 025	167.4 9 000	46.21 226	51.28 250	56.35 275	8.36 2.547	17.64 5.378
HZ 1080M B	17.12 362.4	3,608.3 492 740	160.2 8 615	178.7 9 610	48.14 235	53.20 260	58.27 285	8.36 2.548	17.64 5.378
HZ 1080M C	18.14 383.9	3,905.7 533 350	173.8 9 345	192.0 10 320	51.59 252	56.66 277	61.72 301	8.36 2.549	17.65 5.379
HZ 1080M D	18.96 401.3	4,196.1 573 000	186.3 10 015	205.3 11 030	54.40 266	59.46 290	64.52 315	8.37 2.550	17.65 5.380
HZ 1180M A	19.62 415.2	4,414.2 602 790	195.3 10 500	215.0 11 560	56.64 277	61.70 301	66.76 326	8.37 2.551	17.65 5.381
HZ 1180M B	20.04 424.1	4,605.8 628 950	203.9 10 960	223.4 12 010	58.07 284	63.13 308	68.19 333	8.37 2.552	17.67 5.385
HZ 1180M C	20.85 441.3	4,886.8 667 320	214.8 11 550	236.5 12 715	60.70 296	65.83 321	70.96 346	8.42 2.565	17.70 5.394
HZ 1180M D	21.50 455.0	5,107.8 697 500	225.2 12 105	245.4 13 195	62.90 307	68.03 332	73.15 357	8.44 2.571	17.71 5.399

* Referring outside of HZM-flange (v₂), ** Referring outside of connector (v₃), *** Length of connectors = Length of AZ.

Combination HZ...M-14 / AZ 26-700

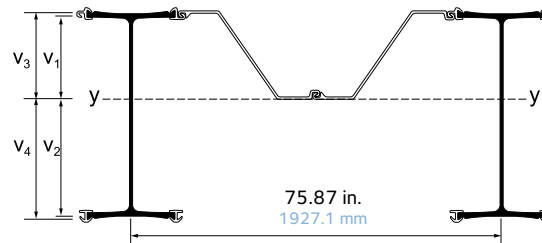

SECTION	PROPERTIES PER FOOT OF WALL				MASS OF COMBINATION WITH INTERMEDIARY SECTION				
	Sectional Area in ² /ft cm ² /m	Moment of Inertia in ⁴ /ft cm ⁴ /m	*Elastic Section Modulus in ³ /ft cm ³ /m	**Elastic Section Modulus in ³ /ft cm ³ /m	*** AZ 26-700			Coating Area	
					ℓAZ = 60% ℓHZ lb/ft ² kg/m ²	ℓAZ = 80% ℓHZ lb/ft ² kg/m ²	ℓAZ = ℓHZ lb/ft ² kg/m ²	Waterside ft ² /ft m ² /m	Landside ft ² /ft m ² /m
HZ 880M A	15.50 328.2	2,133.5 291340	134.7 7240	124.1 6670	41.30 202	47.03 230	52.76 258	8.37 2.551	17.00 5.183
HZ 880M B	16.27 344.4	2,263.9 309150	142.2 7645	131.7 7080	43.93 214	49.65 242	55.38 270	8.38 2.554	17.01 5.186
HZ 880M C	16.63 351.9	2,355.1 321600	147.2 7915	137.0 7365	45.14 220	50.86 248	56.58 276	8.38 2.554	17.01 5.186
HZ 1080M A	17.47 369.8	3,787.7 517240	183.4 9860	172.1 9255	47.97 234	53.71 262	59.45 290	8.36 2.547	18.42 5.613
HZ 1080M B	18.03 381.5	4,028.5 550120	194.0 10430	183.1 9845	49.86 243	55.61 271	61.35 300	8.36 2.548	18.42 5.614
HZ 1080M C	19.04 403.0	4,322.5 590270	207.0 11130	196.5 10565	53.32 260	59.05 288	64.79 316	8.36 2.548	18.42 5.616
HZ 1080M D	19.86 420.4	4,610.6 629600	219.2 11785	209.6 11270	56.13 274	61.86 302	67.59 330	8.37 2.550	18.43 5.616
HZ 1180M A	20.52 434.3	4,826.7 659120	227.8 12245	219.4 11795	58.37 285	64.09 313	69.82 341	8.37 2.551	18.43 5.617
HZ 1180M B	20.91 442.6	5,003.2 683220	235.2 12645	227.5 12230	59.70 291	65.43 319	71.16 347	8.37 2.552	18.43 5.619
HZ 1180M C	21.97 465.1	5,393.0 736440	250.9 13490	242.4 13030	62.84 307	68.81 336	74.78 365	8.42 2.565	18.54 5.652
HZ 1180M D	22.56 477.5	5,582.2 762290	258.8 13915	250.9 13490	64.84 317	70.81 346	76.77 375	8.44 2.571	18.56 5.659

* Referring outside of HZM-flange (highest value of v₁; v₂), ** Referring outside of connector (highest value of v₃; v₄), *** Length of connectors = Length of AZ.

Combination HZ...M-24 / AZ 26-700

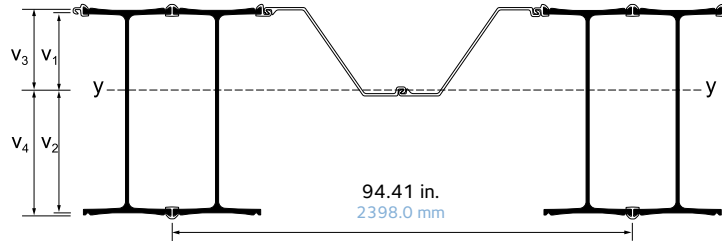

SECTION	PROPERTIES PER FOOT OF WALL				MASS OF COMBINATION WITH INTERMEDIARY SECTION				
	Sectional Area in ² /ft cm ² /m	Moment of Inertia in ⁴ /ft cm ⁴ /m	*Elastic Section Modulus in ³ /ft cm ³ /m	**Elastic Section Modulus in ³ /ft cm ³ /m	*** AZ 26-700			Coating Area	
					ℓAZ = 60% ℓHZ lb/ft ² kg/m ²	ℓAZ = 80% ℓHZ lb/ft ² kg/m ²	ℓAZ = ℓHZ lb/ft ² kg/m ²	Waterside ft ² /ft m ² /m	Landside ft ² /ft m ² /m
HZ 880M A	18.15 384.1	2,757.2 376 510	164.1 8 825	151.9 8 165	53.64 262	57.70 282	61.76 302	10.09 3.074	18.01 5.489
HZ 880M B	19.38 410.1	2,966.7 405 120	176.7 9 500	164.1 8 825	57.83 282	61.89 302	65.94 322	10.11 3.081	18.03 5.495
HZ 880M C	19.95 422.2	3,113.4 425 160	185.0 9 945	172.6 9 280	59.77 292	63.82 312	67.88 331	10.11 3.080	18.03 5.495
HZ 1080M A	21.32 451.3	5,134.3 701 120	237.1 12 745	223.1 11 995	64.40 314	68.48 334	72.55 354	10.06 3.066	19.41 5.915
HZ 1080M B	22.21 470.2	5,522.6 754 140	254.3 13 670	240.6 12 935	67.45 329	71.52 349	75.60 369	10.07 3.068	19.41 5.918
HZ 1080M C	23.83 504.5	5,994.1 818 530	275.6 14 815	262.1 14 090	72.97 356	77.04 376	81.11 396	10.08 3.072	19.42 5.921
HZ 1080M D	25.15 532.4	6,456.7 881 700	295.6 15 890	283.1 15 220	77.47 378	81.54 398	85.60 418	10.08 3.073	19.43 5.922
HZ 1180M A	26.20 554.6	6,803.1 929 010	309.8 16 655	298.8 16 065	81.05 396	85.11 416	89.17 435	10.09 3.074	19.43 5.923
HZ 1180M B	26.83 568.0	7,087.1 967 790	321.9 17 305	311.6 16 755	83.19 406	87.26 426	91.32 446	10.10 3.077	19.46 5.932
HZ 1180M C	28.22 597.4	7,583.3 1 035 550	342.7 18 425	331.4 17 815	87.82 429	91.94 449	96.05 469	10.15 3.094	19.51 5.945
HZ 1180M D	29.16 617.2	7,885.8 1 076 850	355.6 19 120	345.0 18 550	91.01 444	95.12 464	99.23 485	10.19 3.107	19.54 5.955

* Referring outside of HZM-flange (highest value of v₁; v₂), ** Referring outside of connector (highest value of v₃; v₄), *** Length of connectors = Length of AZ.

Combination HZ...M-26 / AZ 26-700

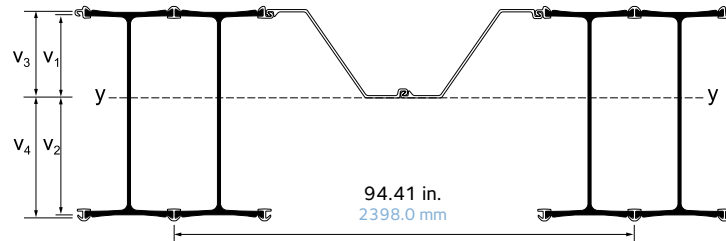

SECTION	PROPERTIES PER FOOT OF WALL				MASS OF COMBINATION WITH INTERMEDIARY SECTION				
	Sectional Area in ² /ft cm ² /m	Moment of Inertia in ⁴ /ft cm ⁴ /m	*Elastic Section Modulus in ³ /ft cm ³ /m	**Elastic Section Modulus in ³ /ft cm ³ /m	*** AZ 26-700			Coating Area	
					ℓAZ = 60% ℓHZ lb/ft ² kg/m ²	ℓAZ = 80% ℓHZ lb/ft ² kg/m ²	ℓAZ = ℓHZ lb/ft ² kg/m ²	Waterside ft ² /ft m ² /m	Landside ft ² /ft m ² /m
HZ 880M A	18.94 400.9	2,970.4 405 620	187.7 10 090	172.9 9 295	55.25 270	59.86 292	64.46 315	10.09 3.074	18.72 5.706
HZ 880M B	20.17 426.9	3,178.5 434 040	199.9 10 745	185.0 9 945	59.45 290	64.04 313	68.64 335	10.11 3.081	18.74 5.713
HZ 880M C	20.74 438.9	3,324.8 454 020	208.0 11 185	193.4 10 400	61.38 300	65.98 322	70.57 345	10.11 3.080	18.74 5.712
HZ 1080M A	22.11 468.1	5,492.6 750 050	266.2 14 310	249.8 13 430	66.02 322	70.64 345	75.26 367	10.06 3.066	20.12 6.132
HZ 1080M B	23.01 487.0	5,879.9 802 940	283.4 15 235	267.4 14 375	69.07 337	73.69 360	78.31 382	10.07 3.068	20.13 6.135
HZ 1080M C	24.63 521.3	6,349.5 867 060	304.3 16 360	288.8 15 525	74.59 364	79.20 387	83.81 409	10.08 3.072	20.14 6.138
HZ 1080M D	25.95 549.2	6,810.8 930 050	323.9 17 415	309.8 16 655	79.09 386	83.70 409	88.30 431	10.08 3.073	20.14 6.139
HZ 1180M A	27.00 571.4	7,156.2 977 220	337.9 18 165	325.5 17 500	82.67 404	87.27 426	91.87 449	10.09 3.074	20.15 6.140
HZ 1180M B	27.63 584.7	7,439.8 1 015 950	350.0 18 815	338.4 18 195	84.81 414	89.41 437	94.02 459	10.10 3.077	20.16 6.144
HZ 1180M C	29.22 618.4	8,021.5 1 095 390	374.6 20 140	361.8 19 450	89.85 439	94.64 462	99.43 485	10.15 3.094	20.28 6.181
HZ 1180M D	30.15 638.2	8,323.0 1 136 560	387.3 20 825	375.4 20 185	93.03 454	97.82 478	102.61 501	10.19 3.107	20.32 6.194

* Referring outside of HZM-flange (highest value of v_1 ; v_2), ** Referring outside of connector (highest value of v_3 ; v_4), *** Length of connectors = Length of AZ.

Combination C 1

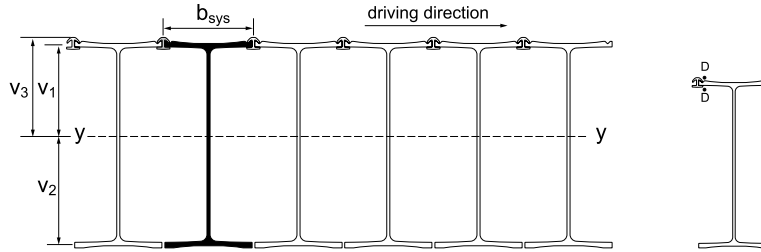

D = discontinuous weld, $a = 0.236"$ (6 mm), 10% of length (3.94" per 3.28'; 100 mm/m), over the whole pile length + 19.68" (500 mm) continuous weld at top and toe

SECTION	Dimensions					PROPERTIES PER FOOT OF WALL					Coating Area	
	b_{sys} in mm	v_1 in mm	v_2 in mm	v_3 in mm	v_4 in mm	Sectional Area in ² /ft cm ² /m	Mass lb/ft ² kg/m ²	Moment of Inertia in ⁴ /ft cm ⁴ /m	*Elastic Section Modulus in ³ /ft cm ³ /m	**Elastic Section Modulus in ³ /ft cm ³ /m	Waterside ft ² /ft m ² /m	Landside ft ² /ft m ² /m
HZ 880M A	18.70 47.5	14.96 379.9	16.67 423.5	16.31 414.3	-	31.28 662.1	106.46 519.8	5,939.0 811 010	356.2 19 150	364.1 19 575	1.81 0.551	9.85 3.001
HZ 880M B	18.70 47.5	15.13 384.3	16.66 423.1	16.41 416.7	-	34.37 727.6	116.98 571.1	6,464.9 882 820	388.1 20 865	394.0 21 185	1.82 0.554	9.85 3.003
HZ 880M C	18.70 47.5	15.24 387.1	16.71 424.3	16.44 417.5	-	35.81 758.1	121.88 595.1	6,836.8 933 600	409.2 22 000	415.9 22 360	1.82 0.554	9.85 3.002
HZ 1080M A	18.50 47.0	19.72 500.9	21.52 546.5	21.08 535.3	-	39.49 835.9	134.40 656.2	11,736.7 1 602 720	545.5 29 330	556.9 29 940	1.79 0.547	11.26 3.431
HZ 1080M B	18.50 47.0	19.91 505.6	21.57 547.8	21.14 537.1	-	41.82 885.1	142.31 694.8	12,745.5 1 740 470	591.0 31 775	602.8 32 410	1.80 0.548	11.26 3.431
HZ 1080M C	18.50 47.0	20.10 510.6	21.61 548.8	21.22 539.0	-	45.86 970.7	156.08 762.0	13,915.7 1 900 270	644.0 34 625	655.7 35 255	1.80 0.549	11.26 3.433
HZ 1080M D	18.50 47.0	20.31 515.9	21.71 551.5	21.27 540.3	-	49.17 1 040.9	167.35 817.1	15,075.7 2 058 680	694.3 37 330	708.7 38 100	1.80 0.550	11.26 3.433
HZ 1180M A	18.70 47.5	20.51 520.9	21.83 554.5	21.31 541.3	-	51.79 1 096.3	176.26 860.6	15,938.9 2 176 560	730.1 39 250	747.9 40 210	1.81 0.551	11.27 3.434
HZ 1180M B	18.70 47.5	20.65 524.5	21.84 554.9	21.38 543.0	-	53.51 1 132.6	182.11 889.1	16,715.1 2 282 550	765.2 41 140	781.9 42 040	1.82 0.553	11.29 3.440
HZ 1180M C	18.70 47.5	20.58 522.8	22.07 560.6	21.34 542.1	-	56.58 1 197.6	192.56 940.1	17,798.2 2 430 450	806.4 43 355	833.9 44 835	1.83 0.558	11.34 3.457
HZ 1180M D	18.70 47.5	20.78 527.9	22.03 559.5	21.46 545.2	-	59.12 1 251.5	201.21 982.4	18,656.7 2 547 690	846.9 45 530	869.3 46 735	1.85 0.564	11.37 3.464

* Referring outside of HZM-flange (v_2). ** Referring outside of connector (v_3).

Combination C 23

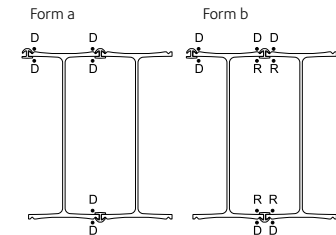
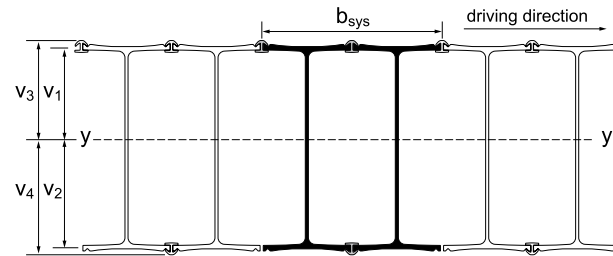

D = discontinuous weld, a = 0.236" (6 mm), 10% of length (3.94" per 3.28'; 100 mm/m) over the whole pile length + 19.68" (500 mm) continuous weld at top and toe
 R = continuous weld, a = 0.236" (6 mm), length 19.68" (500 mm) at top and toe only

SECTION	Dimensions					PROPERTIES PER FOOT OF WALL						Coating Area	
	b _{sys} in mm	v ₁ in mm	v ₂ in mm	v ₃ in mm	v ₄ in mm	Sectional Area in ² /ft cm ² /m	Mass lb/ft ² kg/m ²	Moment of Inertia in ⁴ /ft cm ⁴ /m	*Elastic Section Modulus in ³ /ft cm ³ /m	**Elastic Section Modulus in ³ /ft cm ³ /m	Waterside ft ² /ft m ² /m	Landside ft ² /ft m ² /m	
HZ 880M A	37.40 95.0	15.31 389.0	16.32 414.4	16.67 423.4	17.67 448.9	31.97 676.7	108.81 531.2	6,126.0 836 540	375.4 20 185	346.6 18 635	3.53 1.074	11.62 3.542	
HZ 880M B	37.40 95.0	15.44 392.1	16.35 415.3	16.72 424.6	17.63 447.7	35.03 741.5	119.21 582.0	6,641.1 906 880	406.2 21 840	376.7 20 255	3.55 1.081	11.64 3.549	
HZ 880M C	37.40 95.0	15.54 394.6	16.41 416.8	16.73 425.1	17.61 447.3	36.47 772.0	124.12 606.0	7,012.4 957 590	427.3 22 975	398.2 21 410	3.54 1.080	11.64 3.548	
HZ 1080M A	37.00 94.0	20.09 510.4	21.14 537.0	21.45 544.8	22.50 571.4	40.19 850.8	136.79 667.9	12,054.7 16 461 40	570.2 30 655	535.9 28 810	3.50 1.066	13.02 3.969	
HZ 1080M B	37.00 94.0	20.24 514.1	21.23 539.3	21.48 545.5	22.47 570.7	42.48 899.2	144.57 705.9	13,045.2 17 814 00	614.5 33 035	580.6 31 215	3.51 1.068	13.03 3.971	
HZ 1080M C	37.00 94.0	20.40 518.3	21.30 541.1	21.52 546.7	22.42 569.6	46.52 984.8	158.33 773.0	14,212.4 19 407 90	667.1 35 865	633.8 34 075	3.52 1.072	13.04 3.974	
HZ 1080M D	37.00 94.0	20.59 523.1	21.43 544.3	21.55 547.5	22.39 568.8	49.84 1054.9	169.60 828.1	15,370.6 20 989 50	717.2 38 560	686.4 36 905	3.52 1.073	13.04 3.975	
HZ 1180M A	37.40 95.0	20.77 527.6	21.57 547.8	21.58 548.0	22.37 568.2	52.45 1 110.2	178.50 871.5	16,231.2 22 164 70	752.6 40 460	725.6 39 010	3.52 1.074	13.05 3.977	
HZ 1180M B	37.40 95.0	20.86 529.9	21.63 549.5	21.59 548.3	22.36 567.9	54.05 1 144.1	183.95 898.1	16,952.4 23 149 50	783.6 42 130	758.2 40 765	3.54 1.078	13.08 3.988	
HZ 1180M C	37.40 95.0	20.87 530.2	21.78 553.2	21.64 549.5	22.54 572.5	57.37 1 214.4	195.26 953.3	18,147.9 24 782 00	833.3 44 800	805.2 43 290	3.57 1.087	13.15 4.009	
HZ 1180M D	37.40 95.0	20.97 532.7	21.84 554.7	21.65 550.0	22.52 572.0	59.68 1 263.2	203.09 991.6	18,888.9 25 794 00	864.9 46 500	838.8 45 095	3.61 1.099	13.18 4.018	

* Referring outside of HZM-flange (v₂). ** Referring outside of connector (v₃).

Available Steel Grades								
AMERICAN			CANADIAN			EUROPEAN		
ASTM	YIELD STRENGTH		CSA G40.21	YIELD STRENGTH		EN 10248	YIELD STRENGTH	
	(ksi)	(MPa)		(ksi)	(MPa)		(ksi)	(MPa)
A 328	39	270	Grade 260 W	38	260	S 240 GP	35	240
A 572 Grade 42	42	290	Grade 300 W	43	297	S 270 GP	39	270
A 572 Grade 50	50	345	Grade 355 W	51	355	S 320 GP	46	315
A 572 Grade 55	55	380	Grade 400 W	58	400	S 355 GP	51	355
A 572 Grade 60	60	415				S 390 GP	57	390
A 572 Grade 65	65	450				S 430 GP	62	430
A 690	50	345				S 460 AP*	67	460
A 690*	57	390						

* Not available for AZ 36-700N and larger.

Delivery Conditions & Tolerances

HZM & AZ PILES	ASTM A 6	EN 10248
Mass	± 2.5%	± 5%
Length	+ 5 inches - 0 inches	± 200 mm
Height		± 5 mm
Width		± 2%
Width interlocked		± 3%
Straightness		0.2% of the length
Ends out of Square		± 2% of the width
AZ PILE		
Thickness		≤ 8.5 mm ± 0.5 mm > 8.5 mm ± 6%
HZM PILE		
Thickness		≤ 12.5 mm + 2.0, -1.0 mm > 12.5 + 2.5, -1.5 mm

Maximum Rolled Lengths**

HZM	108.3 feet	(33.0 m)	
AZ	101.7 feet	(31.0 m)	
RZD/RZU	78.7 feet	(24.0 m)	(Length does not restrict wall height)
RH	78.7 feet	(24.0 m)	(Length does not restrict wall height)

** Longer lengths may be possible upon request.

H-Pile

Recycled Content: 100%
Recyclable: 100%

H-pile (also referred to as HBP or HP) is manufactured by Nucor and constitutes most of the steel pile supplied by Skyline Steel. For the first time in several decades, Nucor recently expanded the H-pile range. Traditionally, H-pile was made in 8-, 10-, 12-, and 14-inch sizes. The capacity of previous sections has been nearly doubled through the addition of new ranges of 16- and 18-inch pile. Like all other steel produced using the electric arc furnace, H-pile is made from 100% scrap and is 100% recyclable.

Applications of H-Pile

H-piles are commonly used as bearing piles and are driven into the ground to support bridges, buildings, factories, stadiums, and nearly every other type of structure. H-piles are most effective as end-bearing piles, but also resist load through skin friction. H-piles are also used for walers and bracing in cofferdams and in beam and lagging walls.

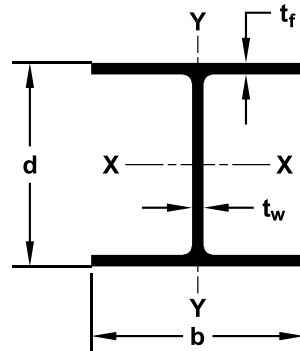

SECTION	Weight lb/ft (kg/m)	Area in ² (cm ²)	Depth d in (mm)	Flange Width b in (mm)	THICKNESS		Coating Area ft ² /ft (m ² /m)	ELASTIC PROPERTIES							
					Flange (t _f) in (mm)	Web (t _w) in (mm)		AXIS X-X				AXIS Y-Y			
								I in ⁴ (cm ⁴)	S in ³ (cm ³)	Z in ³ (cm ³)	r in (cm)	I in ⁴ (cm ⁴)	S in ³ (cm ³)	Z in ³ (cm ³)	r in (cm)
HP 8 HP 200	36	10.6	8.02	8.16	0.445	0.445	3.92	119	29.8	33.6	3.36	40.3	9.88	15.2	1.95
	54	68.4	204	207	11.3	11.3	1.19	4953	488	550.6	8.53	1677	162	249.1	4.95
HP 10 HP 250	42	12.4	9.70	10.10	0.420	0.415	4.83	210	43.4	48.3	4.13	71.7	14.2	21.8	2.41
	63	80.0	246	257	10.7	10.5	1.47	8741	711	791.5	10.5	2984	233	357.2	6.12
HP 12 HP 310	57	16.7	9.99	10.20	0.565	0.565	4.91	294	58.8	66.5	4.18	101	19.7	30.3	2.45
	85	108	254	259	14.4	14.4	1.50	12237	964	1089.7	10.6	4204	323	496.5	6.22
	53	15.5	11.80	12.00	0.435	0.435	5.82	393	66.7	74.0	5.03	127	21.1	32.2	2.86
	79	100	300	305	11.0	11.0	1.77	16358	1093	1212.6	12.8	5286	346	527.7	7.26
HP 14 HP 360	63	18.4	11.90	12.10	0.515	0.515	5.86	472	79.1	88.3	5.06	153	25.3	38.7	2.88
	94	119	302	307	13.1	13.1	1.79	19646	1296	1447.0	12.9	6368	415	634.2	7.32
	74	21.8	12.10	12.20	0.610	0.605	5.91	569	93.8	105	5.11	186	30.4	46.6	2.92
	110	141	307	310	15.5	15.4	1.80	23683	1537	1720.6	13.0	7742	498	763.6	7.42
HP 16 HP 410	84	24.6	12.30	12.30	0.685	0.685	5.97	650	106	120	5.14	213	34.6	53.2	2.94
	125	159	312	312	17.4	17.4	1.82	27055	1737	1966.4	13.1	8866	567	871.8	7.47
	73	21.4	13.60	14.60	0.505	0.505	6.96	729	107	118	5.84	261	35.8	54.6	3.49
	109	138	345	371	12.8	12.8	2.12	30343	1753	1933.7	14.8	10864	587	894.7	8.86
HP 18 HP 460	89	26.1	13.80	14.70	0.615	0.615	7.02	904	131	146	5.88	326	44.3	67.7	3.53
	132	168	351	373	15.6	15.6	2.14	37627	2147	2392.5	14.9	13569	726	1109.4	8.97
	102	30.1	14.00	14.80	0.705	0.705	7.06	1050	150	169	5.92	380	51.4	78.8	3.56
	152	194	356	376	17.9	17.9	2.15	43704	2458	2769.4	15.0	15817	842	1291.3	9.04
HP 18 HP 460	117	34.4	14.20	14.90	0.805	0.805	7.12	1220	172	194	5.96	443	59.5	91.4	3.59
	174	222	361	378	20.4	20.4	2.34	50780	2819	3179.1	15.1	18439	975	1497.8	9.12
	88	25.8	15.30	15.70	0.540	0.540	7.52	1110	145	161	6.56	349	44.5	68.2	3.68
	131	167	389	399	13.7	13.7	2.29	46201	2376	2638.3	16.7	14526	729	1117.6	9.35
	101	29.9	15.50	15.80	0.625	0.625	7.56	1300	168	187	6.59	412	52.2	80.1	3.71
	150	193	394	401	15.9	15.9	2.30	54110	2753	3064.4	16.7	17149	855	1312.6	9.42
	121	35.8	15.80	15.90	0.750	0.750	7.62	1590	201	226	6.66	504	63.4	97.6	3.75
180	231	401	404	19.1	19.1	2.32	66180	3294	3703.5	16.9	20978	1039	1599.4	9.53	
141	41.7	16.00	16.00	0.875	0.875	7.69	1870	234	264	6.70	599	74.9	116	3.79	
210	269	406	406	22.2	22.2	2.34	77835	3835	4326.2	17.0	24932	1227	1900.9	9.63	
162	47.7	16.30	16.10	1.000	1.000	7.75	2190	269	306	6.78	697	86.6	134	3.82	
241	308	414	409	25.4	25.4	2.36	91154	4408	5014.4	17.2	29011	1419	2195.9	9.70	
183	54.1	16.50	16.30	1.130	1.130	7.81	2510	304	349	6.81	818	100.0	156	3.89	
272	349	419	414	28.7	28.7	2.38	104473	4982	5719.1	17.3	34047	1639	2556.4	9.88	
HP 18 HP 460	135	39.9	17.50	17.80	0.750	0.750	8.54	2200	251	281	7.43	706	79.3	122	4.21
	201	257	445	452	19.1	19.1	2.60	91570	4113	4604.7	18.9	29386	1299	1999.2	10.7
	157	46.2	17.70	17.90	0.870	0.870	8.60	2570	290	327	7.46	833	93.1	143	4.25
	234	298	450	455	22.1	22.1	2.62	106971	4752	5358.5	18.9	34672	1526	2343.3	10.8
181	53.2	18.00	18.00	1.000	1.000	8.66	3020	336	379	7.53	974	108.0	167	4.28	
269	343	457	457	25.4	25.4	2.64	125701	5506	6210.7	19.1	40541	1770	2736.6	10.9	
204	60.2	18.30	18.10	1.130	1.130	8.73	3480	380	433	7.60	1120	124.0	191	4.31	
304	388	465	460	28.7	28.7	2.66	144847	6227	7095.6	19.3	46618	2032	3129.9	11.0	

Available Steel Grades								
AMERICAN			CANADIAN			EUROPEAN**		
ASTM	YIELD STRENGTH		CSA G40.21	YIELD STRENGTH		EN 10034	YIELD STRENGTH	
	(ksi)	(MPa)		(ksi)	(MPa)		(ksi)	(MPa)
A 36	36	250	Grade 300 W	44	300	HISTAR 355	51	355
A 572 Grade 50*	50	345	Grade 350 W	50	350	HISTAR 420	61	420
A 588	50	345				HISTAR 460	67	460
A 690	50	345						

* Standard grade for H-Pile.

**HISTAR only available in some sizes.

Splicer and H-Pile Point



Splicer



H-Pile Point

Delivery Conditions & Tolerances

	ASTM A 6	
Mass	± 2.5%	
Length [§]		
30 Feet and Under	± 0.375 inches	
Over 30 Feet	+ (0.375 inches + (length - 30)/80)	- 0.375 inches
Depth	± 0.125 inches	- 0.1875 inches
Flange Width	+ 0.25 inches	
Flanges out of Square		
HP 8 x 42 - HP 12 x 84	≤ 0.25 inches	
HP 14 x 73 - HP 14 x 117	≤ 0.3125 inches	
Web off Center	≤ 0.1875 inches	
Greatest Depth over Theoretical	≤ 0.25 inches	
Camber and Sweep***		
45 Feet and Under	(0.125")(Length in feet/10) but not over 0.375"	
Over 45 Feet	(0.375") + (0.125" (Length in feet - 45)/10)	

[§]For HP ordered as bearing piles, length tolerances are +5 in. and -0 in.

***For the HP 10 x 42, 12 x 53, 12 x 63, 14 x 73, and 14 x 89 ordered as columns, tolerances are subject to negotiation with manufacturer.

Maximum Rolled Lengths[†]

HPs	100'	30.5 m
-----	------	--------

[†] Longer lengths may be possible upon request.

Recycled Content: 70%
Recyclable: 100%

Skyline Steel manufactures two types of pipe, spiralweld, and rolled and welded. Spiralweld plants are located in Camp Hill, PA, luka, MS and Longview, WA. Rolled and welded pipe is manufactured in Newton, IL and Longview, WA. The differences in the manufacturing process make each of the products more useful for different applications.

Spiralweld Pipe

Spiralweld pipe is manufactured from steel coil. The coil is unwound and then welded while it is being turned into the shape of the pipe. Changing angle of the spiral and the thickness of the coil is all that is needed to change from one pipe size to another. The two sides of the double submerged arc weld penetrate the full thickness of the steel to ensure the strength of the finished pipe. Full scale tests have shown that high quality spiralweld pipe is as strong as API pipe. The strength and flexible manufacturing of spiralweld pipe make it the product of choice for a variety of applications.

Spiralweld pipe is ideal for bearing piles since it can be produced in such a wide variety of sizes, grades, and lengths. It is also easy to splice and can be driven open or closed ended. Closed end pipe can be filled with concrete. The American Society of Civil Engineers (ASCE) recommends a lower safety factor for concrete filled close-ended pipe than any other type of driven or drilled foundation, primarily due to the predictability of a quality installed product. Spiralweld pipe is also used for king piles for pipe-z sheet pile walls, casing for drilled shafts, bracing for cofferdams and sign poles.

Rolled and Welded Pipe

Rolled and welded pipe is made from sections of plate rolled into cans. The seam of the can is welded and then the separate cans are welded together to make the finished pipe. Rolled and welded pipe can be made in diameters up to sixteen feet and over two inches in thickness.

The size of rolled and welded pipe can be used for different types of projects. Vertical shafts for mines can be lined with large diameter casing. Casing can also be used for the ever increasing size of drilled shafts. Jack and bored pipe, high capacity piles, and tanks are other common uses for rolled and welded pipe.

Applications of Manufactured Pipe

Both types of pipe are deployed in non-structural applications such as transmission lines for sewers, force mains, dredge material, slurry, pump stations, cooling water, and irrigation.

Spiralweld Pipe

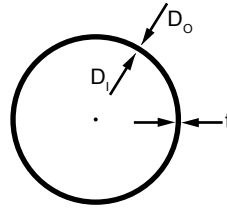

PIPE WEIGHT lbs/ft (kg/m)											
Outside Diameter (D_o) in (mm)	WALL THICKNESS (t) in (mm)										
	0.179 4.55	0.188 4.78	0.203 5.16	0.219 5.56	0.250 6.35	0.312 7.92	0.375 9.53	0.500 12.70	0.625 15.88	0.750 19.05	1.000 25.40
8.625 219.1	16.16 24.05	16.96 25.23	18.28 27.20	19.68 29.29	22.38 33.31						
10 254.0	18.79 27.97	19.72 29.35	21.26 31.64	22.90 34.08	26.06 38.78						
10.75 273.1	20.23 30.10	21.23 31.59	22.89 34.06	24.65 36.69	28.06 41.76	34.81 51.81	40.52 (0.365) 60.30				
12 304.8	22.62 33.66	23.74 35.33	25.60 38.10	27.58 41.04	31.40 46.73	38.98 58.01	46.60 69.35				
12.75 323.9	24.05 35.80	25.25 37.57	27.23 40.52	29.34 43.66	33.41 49.71	41.48 61.74	49.61 73.83				
14 355.6	26.45 39.36	27.76 41.31	29.94 44.56	32.26 48.01	36.75 54.69	45.65 67.94	54.62 81.28	72.16 107.38			
16 406.4	30.27 45.05	31.78 47.29	34.28 51.02	36.95 54.98	42.09 62.64	52.32 77.87	62.64 93.21	82.85 123.29			
18 457.2	34.10 50.75	35.80 53.27	38.62 57.47	41.63 61.95	47.44 70.59	58.99 87.79	70.65 105.15	93.54 139.20			
20 508.0	37.93 56.44	39.82 59.25	42.96 63.93	46.31 68.92	52.78 78.55	65.66 97.72	78.67 117.08	104.23 155.11	129.45 192.64		
24 609.6	45.58 67.83	47.86 71.22	51.64 76.85	55.67 82.85	63.47 94.46	79.01 117.57	94.71 140.94	125.61 186.92	156.17 232.41	186.41 277.40	
30 762.0					79.51 118.32	99.02 147.36	118.76 176.73	157.68 234.65	196.26 292.07	234.51 348.99	310.01 461.35
36 914.4					95.54 142.18	119.03 177.14	142.81 212.53	189.75 282.38	236.35 351.73	282.62 420.58	374.15 556.80
42 1067					111.58 116.05	139.04 206.92	166.86 248.32	221.82 330.10	276.44 411.38	330.72 492.17	438.29 652.25
48 1219					127.61 189.91	159.05 236.70	190.92 284.12	253.89 377.83	316.52 471.04	378.83 563.76	502.43 747.70
54 1372							214.97 319.91	285.96 425.55	356.61 530.70	426.93 635.35	566.57 843.15
60 1524							239.02 355.70	318.03 473.28	396.70 590.35	475.04 706.93	630.71 938.60
72 1829							287.13 427.29	382.17 568.73	476.87 709.67	571.25 850.11	758.99 1129.50
84 2134							335.23 498.88	446.31 664.18	557.05 828.98	667.46 993.29	887.27 1320.41
96 2438								510.45 759.63	637.22 948.30	763.67 1136.46	1015.55 1511.31
108 2743								574.59 855.08	717.40 1067.61	859.88 1279.64	1143.83 1702.21
120 3048								638.73 950.53	797.57 1186.92	958.09 1422.82	1272.11 1893.11

Please inquire about other diameters and thicknesses.

APPROXIMATE VALUES

Pipe Weight (lbs/ft) = 10.69*t*(d-t)
d (in) - outside diameter
t (in) - thickness of pipe

Pipe Weight (kg/m) = 0.0247*t*(d-t)
d (mm) - outside diameter
t (mm) - thickness of pipe

Spiralweld Pipe

Available Steel Grades								
ASTM	YIELD STRENGTH		ASTM	YIELD STRENGTH		ASTM	YIELD STRENGTH	
	(ksi)	(MPa)		(ksi)	(MPa)		(ksi)	(MPa)
A 139 Grade A	30	205	A 252 Grade 1	30	205	A 588	50	345
A 139 Grade B	35	240	A 252 Grade 2	35	240	A 690	50	345
A 139 Grade C	42	290	A 252 Grade 3	45	310	A 572	50	345
A 139 Grade D	46	315	A 252 Grade 3 (Mod)*	50-80	345-555	A 709	50	345
A 139 Grade E	52	360				A 1011/1018	50	345
						Abrasion Resistant	Brinell Hardness - 190	

*Availability is dependent on pipe diameter and thickness.

Easy Weight Calculator (All Dimensions in inches. Density of steel = 0.2836 lbs/in³)

Rectangles and Squares

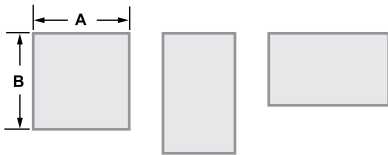

$$\text{Weight (lbs)} = A \times B \times \text{Thickness} \times 0.2836$$

Rings

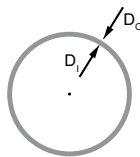

$$\text{Weight (lbs)} = \text{Thickness} \times \frac{\pi}{4} (D_o^2 - D_i^2) \times 0.2836$$

$$\text{Area} = \frac{\pi}{4} (D_o^2 - D_i^2)$$

Circular Plates



$$\text{Weight (lbs)} = \text{Thickness} \times \frac{\pi}{4} (D^2) \times 0.2836$$

$$\text{Area} = \frac{\pi}{4} D^2$$

Delivery Conditions & Tolerances**

	ASTM
Pipe Piles:	± 1%
Outside Diameter	- 5%
Weight/Thickness	± 1 inch
Length	

**Tighter specifications may be possible upon request.

Maximum Rolled Lengths***

Spiralweld	130 feet	(39.6 m)
------------	----------	----------

*** Longer lengths may be possible upon request.

Rolled and Welded Pipe

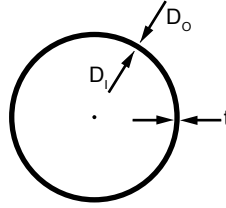

APPROXIMATE VALUES

Pipe Weight (lbs/ft) = $10.69 \cdot t \cdot (D_o - t)$
 D_o (in) - outside diameter
 t (in) - thickness of pipe

Pipe Weight (kg/m) = $0.0247 \cdot t \cdot (D_o - t)$
 D_o (mm) - outside diameter
 t (mm) - thickness of pipe

PIPE WEIGHT lbs/ft (kg/m)														
Outside Diameter (D_o) in (mm)	Wall Thickness (t) in (mm)													
	0.250 6.35	0.312 7.92	0.375 9.52	0.438 11.13	0.500 12.70	0.562 14.27	0.625 15.87	0.688 17.48	0.750 19.05	0.875 22.22	1.000 25.40	1.250 31.75	1.375 34.92	1.50 - 2.25 38.10 - 57.15
24 609.6	63.47 94.45	79.01 117.58	94.71 140.94	110.32 164.17	125.61 186.93	141.05 209.91	156.17 232.41	171.45 255.15	186.41 277.41					
30 762.0	79.51 118.32	99.02 147.36	118.76 176.73	138.42 205.99	157.68 234.65	176.86 263.20	196.26 292.07	215.58 320.82	234.51 348.99	272.43 405.42	310.01 461.35	384.17 571.71		
36 914.4	95.54 142.18	119.03 177.14	142.81 212.53	166.51 247.79	189.75 282.38	212.90 316.83	236.35 351.73	259.71 386.49	282.62 420.59	328.55 488.94	374.15 556.80	464.35 691.03	508.94 757.39	
42 1067	111.58 166.05	139.04 206.91	166.86 248.32	194.60 289.60	221.82 330.11	248.95 370.48	276.44 411.39	303.84 452.16	330.72 492.17	384.67 572.45	438.29 652.25	544.52 810.34	597.14 888.64	Max. wall thickness of 1.50" (38.1mm). Please call for weight.
48 1219	127.61 189.90	159.05 236.69	190.92 284.12	222.70 331.41	253.89 377.83	285.00 424.13	316.52 471.03	347.97 517.84	378.83 563.76	440.80 655.98	502.43 747.70	624.70 929.66	685.33 1019.89	
54 1372	143.65 213.78	179.06 266.47	214.97 319.91	250.79 373.22	285.96 425.56	321.04 477.76	356.61 530.70	392.09 583.50	426.93 635.34	496.92 739.50	566.57 843.15	704.87 1048.96	773.52 1151.13	Max. wall thickness of 1.625" (41.3mm). Please call for weight.
60 1524	159.68 237.63	199.08 296.26	239.02 355.70	278.88 415.02	318.03 473.28	357.09 531.41	396.70 590.36	436.22 649.17	475.04 706.94	553.04 823.02	630.71 938.60	785.05 1168.29	861.71 1282.37	
66 1676	175.72 261.50	219.09 326.04	263.07 391.49	306.98 456.84	350.10 521.01	393.14 585.06	436.79 650.02	480.35 714.84	523.14 778.52	609.16 906.53	694.85 1034.05	865.22 1287.59	949.91 1413.62	Max. wall thickness of 1.75" (44.4mm). Please call for weight.
72 1829	191.75 285.36	239.10 355.82	287.13 427.30	335.07 498.64	382.17 568.73	429.18 638.69	476.87 709.66	524.48 780.51	571.25 850.12	665.29 990.06	758.99 1129.50	945.40 1406.91	1038.10 1544.87	
78 1981	207.79 309.23	259.11 385.60	311.18 463.09	363.16 540.44	414.24 616.46	465.23 692.34	516.96 769.32	568.61 846.19	619.35 921.70	721.41 1073.58	823.13 1224.95	1025.57 1526.22	1126.29 1676.11	Max. wall thickness of 2.00" (50.8mm). Please call for weight.
84 2134	223.82 333.08	279.12 415.38	335.23 498.88	391.26 582.26	446.31 664.18	501.28 745.99	557.05 828.98	612.74 911.86	667.46 993.29	777.53 1157.09	887.27 1320.41	1105.75 1645.54	1214.48 1807.35	
90 2286	239.86 356.95	299.13 445.16	359.28 534.67	419.35 624.06	478.38 711.91	537.32 799.62	597.14 888.64	656.86 977.52	715.56 1064.87	833.65 1240.61	951.41 1415.86	1185.92 1764.85	1302.68 1938.61	Max. wall thickness of 2.25" (57.1mm). Please call for weight.
96 2438	255.89 380.81	319.15 474.95	383.34 570.47	447.44 665.87	510.45 759.63	573.37 853.27	637.22 948.29	700.99 1043.19	763.67 1136.47	889.78 1324.14	1015.55 1511.31	1266.10 1884.17	1390.87 2069.85	
102 2591	271.93 404.68	339.16 504.73	407.39 606.26	475.54 707.68	542.52 807.36	609.42 906.92	677.31 1007.95	745.12 1108.86	811.77 1208.05	945.90 1407.66	1079.69 1606.76	1346.27 2003.47	1479.06 2201.09	Max. wall thickness of 2.25" (57.1mm). Please call for weight.
108 2743	287.96 428.53	359.17 534.50	431.44 642.05	503.63 749.49	574.59 855.09	645.46 960.55	717.40 1067.61	789.25 1174.54	859.88 1279.65	1002.02 1491.17	1143.83 1702.21	1426.45 2122.80	1567.25 2332.33	
114 2896	304.00 452.40	379.18 564.28	455.49 677.85	531.72 791.29	606.66 902.81	681.51 1014.20	757.49 1127.27	833.38 1240.21	907.98 1351.23	1210.48 1801.40	1207.97 1797.66	1506.62 2242.10	1655.45 2463.59	Max. wall thickness of 2.25" (57.1mm). Please call for weight.
120 3048	320.03 476.26	399.19 594.06	479.55 713.65	559.82 833.11	638.73 950.54	717.56 1067.85	797.57 1186.92	877.51 1305.88	956.09 1422.82	1274.62 1896.85	1272.11 1893.11	1586.80 2361.42	1743.64 2594.83	
126 3200		419.20 623.84	503.60 749.44	587.91 874.91	670.80 998.26	753.60 1121.48	837.66 1246.58	921.63 1371.54	1004.19 1494.40	1338.76 1992.30	1336.25 1988.56	1666.97 2480.73	1831.83 2726.07	Max. wall thickness of 2.25" (57.1mm). Please call for weight.
132 3353		439.22 653.63	527.65 785.23	616.00 916.71	702.87 1045.99	789.65 1175.13	877.75 1306.24	965.76 1437.21	1052.30 1566.00	1402.90 2087.75	1400.39 2084.01	1747.15 2600.05	1920.02 2857.31	
138 3505			551.70 821.02	644.10 958.53	734.94 1093.71	825.70 1228.78	917.84 1365.90	1009.89 1502.88	1100.40 1637.58	1467.07 2183.25	1464.53 2179.36	1827.32 2719.36	2008.22 2988.57	Max. wall thickness of 2.25" (57.1mm). Please call for weight.
144 3657.6			575.76 856.83	672.19 1000.33	767.01 1141.44	861.74 1282.41	957.92 1425.54	1054.02 1568.56	1148.51 1709.17	1531.18 2278.65	1528.67 2274.92	1907.50 2838.68	2096.41 3119.81	
150 3810			599.81 892.62	700.28 1042.13	799.08 1189.16	897.79 1336.06	998.01 1485.21	1098.15 1634.23	1196.61 1780.76	1595.32 2374.10	1592.81 2370.37	1987.67 2957.98	2184.60 3251.05	Max. wall thickness of 2.25" (57.1mm). Please call for weight.
156 3962			623.86 928.41	728.38 1083.95	831.15 1236.89	933.84 1389.71	1038.10 1544.87	1142.28 1699.90	1244.72 1852.35	1659.46 2469.55	1656.95 2465.82	2067.85 3077.31	2272.79 3382.29	
162 4115				756.47 1125.75	863.22 1284.62	969.88 1443.34	1078.19 1604.53	1186.40 1765.56	1292.82 1923.93	1723.82 2565.33	1721.09 2561.27	2148.02 3196.61	2360.99 3513.55	Max. wall thickness of 2.25" (57.1mm). Please call for weight.
168 4267				784.56 1167.56	895.29 1332.34	1005.93 1496.99	1118.27 1664.17	1230.53 1831.23	1340.93 1995.53	1787.74 2660.46	1785.23 2656.72	2228.20 3315.93	2449.18 3644.79	
169-204 4293 - 5182	Please call for weight.													

Rolled and Welded Pipe

Available Steel Grades								
ASTM	YIELD STRENGTH		ASTM	YIELD STRENGTH		ASTM	YIELD STRENGTH	
	(ksi)	(MPa)		(ksi)	(MPa)		(ksi)	(MPa)
A 36	36	250	A 252 Grade 1	30	205	A 516 Grade 70	38	260
A 139 Grade A	30	205	A 252 Grade 2	35	240	A 572 Grade 42	42	290
A 139 Grade B	35	240	A 252 Grade 3	45	310	A 572 Grade 50	50	345
A 139 Grade C	42	290	A 252 Grade 3 (Mod)	50	345	A 572 Grade 55	55	380
A 139 Grade D	46	315	A 516 Grade 55	30	205	A 572 Grade 60	60	415
A 139 Grade E	52	360	A 516 Grade 60	32	220	A 572 Grade 65	65	450
			A 516 Grade 65	35	240	A 588	50	345

Additional grades available upon request.

Additional Capabilities

Installation of:

Bands, Cutting Shoes, End Plates, Carbide Teeth, Rolled Channel and Angle Iron, Twisting Slots, Picking Eyes, Lifting Lugs, etc.

Fabrication of Segmented Fittings:

Elbows, Wyes, Laterals, Tees, Concentric and Eccentric Reducers.

Manufacturers of concentric tapered pipe from .250" to 2" wall thickness.

Pipe manufactured to American Welding Society. Structural welding code AWS D1.1 or D1.5 is also available.

Delivery Conditions & Tolerances

	ASTM
Outside Diameter	± 1%
Weight/Thickness	Per Specification
Length	± 1 inch

Maximum Rolled Lengths*

Rolled & Welded	120 feet	(36.6 m)
-----------------	----------	----------

* Longer lengths may be possible upon request.

Pile Accessories

Recycled Content: 100%
Recyclable: 100%

Since geotechnical exploration and pile driving are not exact sciences, it is often challenging to predict the difficulty of driving piles and also to determine what their final lengths will be. To assist engineers and contractors in the construction of deep foundations, pile splicers, shoes, points, and other accessories are available.

Applications of Pile Accessories

Pile splicers are used to splice steel, concrete, and wood piles. They are used in situations where final pile lengths need to be longer than what could otherwise be reasonably handled and delivered, or in low head room applications. Shoes and points protect the ends of piles, ease installation and in the case of pipe, prevent soil intrusion so the pipe can be filled with concrete. Extruded corner piles are also available to ease construction of sheet pile walls. Pile accessories can be custom-made to fit any almost any requirement.

Pile Accessories

HP Accessories



HP Point



HP Splicer



HP Point



HP Point

Sheet Pile Accessories



Sheet Pile Protector



Sheet Pile Protector

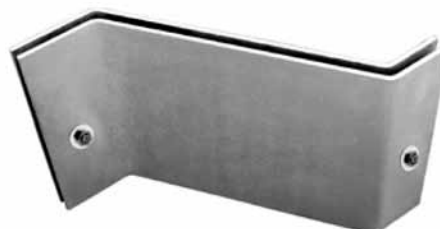

Sheet Pile Splicer

Pile Accessories

Pipe Accessories

Open-Ended Cutting Shoes



Outside Flange



Inside Flange

Drive-On Pipe Pile Splicer



Conical Points



Inside Flange (60°)



Inside Flange (60°)

Drive-Tite Boot



Backing Ring

Timber Accessories



Timber Boot



Timber Point

Contact Information

Associated Pile & Fitting
Tel: (973) 773-8400
Toll Free: (800) 526-9047
Fax: (973) 428-5146
apf@associatedpile.com
www.associatedpile.com

Threaded Bar

Recycled Content: 100%
Recyclable: 100%

A threaded bar is a long piece of hot-rolled bar with cold-pressed threads. The threads are pressed instead of cut for two reasons. Cut threads disrupt the grain pattern of the steel more than pressed threads, and therefore weaken the bar more. Pressed threads are also easier to manufacture than cut threads.

Applications of Threaded Bar

Threaded bar is used for a wide variety of applications, including tie rods and tie backs, to support retaining walls, which are too high to cantilever. Threaded bar is also used as reinforcement for micropiles and high capacity drilled shafts. Its advantage over traditional reinforcement is that it can be made in much higher grades and is coupled (versus being tied). In addition to its use in traditional deep foundations, threaded bar is also suitable for soil nails, rock bolts, roof bolts, and reinforcement of post-tensioned slabs.

Threaded Bar and Accessories

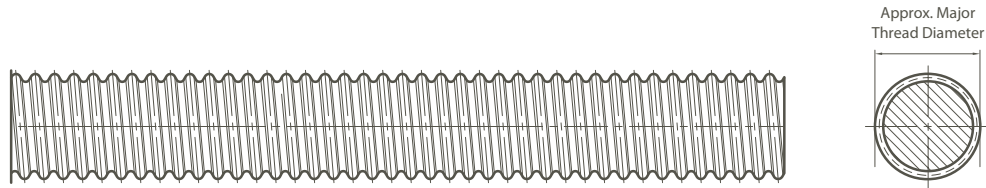

Threaded Bar - Grade 75								
Bar Designation	Nominal Diameter	Minimum Net Area Thru Threads	Minimum Ultimate Strength	Minimum Yield Strength	Nominal Weight	Approx. Major Thread Diameter	Thread Orientation*	Max. Length
	in (mm)	in ² (mm ²)	kips (kN)	kips (kN)	lbs/ft (kg/m)	in (mm)		
#8	1 25	0.790 510.0	79 351.4	59.3 263.8	2.70 4.0	1 1/8 28.5	Left Hand	60 18.3
#9	1 1/8 28	1.000 645.0	100 444.8	75 333.6	3.40 5.1	1 1/4 32.0	Left Hand	60 18.3
#10	1 1/4 32	1.270 819.0	127 564.9	95.3 423.9	4.30 6.4	1 3/8 35.0	Left Hand	60 18.3
#11	1 3/8 35	1.560 1006.0	156 694.0	117 520.5	5.30 7.9	1 1/2 38.1	Left Hand	60 18.3
#14	1 3/4 45	2.250 1452.0	225 1000.9	168.7 750.4	7.65 11.4	1 7/8 47.6	Right Hand	60 18.3
#18	2 1/4 55	4.000 2581.0	400 1779.4	300 1334.5	13.60 20.2	2 3/8 62.0	Right Hand	60 18.3
#20**	2 1/2 64	4.910 3168.0	491 2184.0	368 1637.0	16.69 24.8	2 3/4 70.0	Right Hand	60 18.3
#24**	3 76	7.070 4417.0	707 3142.0	530 2356.0	24.10 35.9	3 1/4 82.6	Right Hand	60 18.3
#28**	3 1/2 89	9.610 6200.0	960 4274.0	720 3206.0	32.70 48.7	3 3/4 95.3	Right Hand	60 18.3

#8-#18: ASTM A615. #20-#28: Meet physical properties. *Other thread orientation available upon request.

** The yield and tensile strength are verified through the industry standard 505 section test. Full section testing is available upon request.

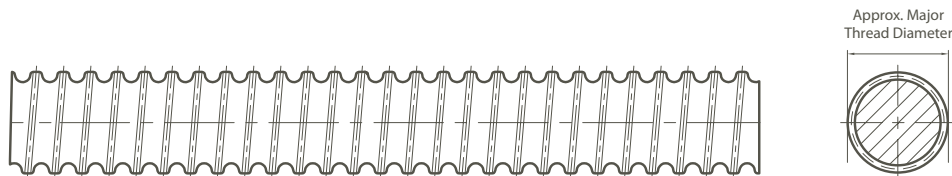

Threaded Bar - Grade 150							
Nominal Diameter	Minimum Net Area Thru Threads	Minimum Ultimate Strength	Minimum Yield Strength	Nominal Weight	Approx. Major Thread Diameter	Thread Orientation*	Max. Length
in (mm)	in ² (mm ²)	kips (kN)	kips (kN)	lbs/ft (kg/m)	in (mm)		
1 26	0.850 549	128 567	102 454	3.1 4.6	1 1/8 28.6	Left Hand	60 18.3
1 1/4 32	1.250 807	188 834	150 667	4.5 6.7	1 1/2 38.1	Left Hand	60 18.3
1 3/8 36	1.580 1019	237 1054	190 843	5.7 8.5	1 5/8 41.3	Left Hand	60 18.3
1 3/4 46	2.600 1664	400 1779	320 1423	9.1 13.5	2 50.8	Left Hand	50 15.2
2 1/2 65	5.190 3350	778 3457	622 2766	18.3 27.2	2 3/4 69.9	Left Hand	50 15.2
3 75	7.060 4169	1059 4702	847 3766	24.0 35.7	3 1/4 82.6	Left Hand	50 15.2

1 inch to 1 1/8 inch: ASTM A-722. 1 1/8 inch to 3 inches: Certified ksi only. *Other thread orientation available upon request.

Threaded Bar and Accessories

Threaded Bar Connectors

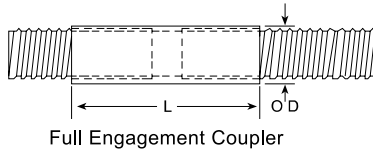

Hex Nuts (Full and Jam Nuts)

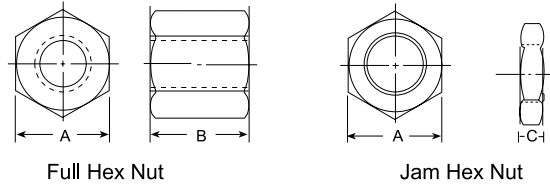

Grade 75 Bar			
Bar Designation	OD in (mm)	L in (mm)	Weight lbs (kg)
#8	1.625 41.3	4.500 114.3	1.64 0.74
#9	1.875 47.6	5.000 127.0	2.51 1.14
#10	2.125 54.0	5.500 139.7	3.00 1.36
#11	2.250 57.2	6.000 152.4	4.25 1.93
#14	2.875 73.0	7.875 200.0	9.29 4.21
#18	3.500 88.9	9.125 231.8	14.40 6.53
#20	4.000 101.6	9.500 241.3	22.40 10.16
#24	4.750 120.6	10.750 243.0	31.00 14.06
#28	5.500 139.7	12.000 304.8	48.20 21.86

Grade 75 Bar					
Bar Designation	A in (mm)	B in (mm)	C in (mm)	Weight lbs (kg)	
				Full	Jam
#8	1.625 41.3	2.000 50.8	0.500 12.7	0.88 0.40	0.22 0.10
#9	1.750 44.5	2.000 50.8	0.563 14.3	0.96 0.44	0.27 0.12
#10	2.000 50.8	2.187 55.5	0.625 15.9	1.43 0.65	0.40 0.18
#11	2.250 57.2	2.500 63.5	0.688 17.5	2.12 0.96	0.58 0.26
#14	2.750 69.9	3.250 82.6	0.938 23.8	3.90 1.77	1.10 0.50
#18*	3.500 88.9	3.500 88.9	1.000 25.4	6.73 3.05	1.92 0.87
#20*	4.000 101.6	4.000 101.6	1.125 28.6	10.40 4.72	2.93 1.33
#24**	4.750 120.6	4.500 114.3	1.500 38.1	13.70 6.21	4.30 1.95
#28**	5.500 139.7	6.000 152.4	1.563 39.7	28.92 13.12	7.53 3.42

*Round collar nut available **Round collar nut with flats

Grade 150 Bar			
Nominal Diameter in (mm)	OD in (mm)	L in (mm)	Weight lbs (kg)
1 26	1.750 44.5	4.250 108.0	1.96 0.89
1 ¼ 32	2.125 54.0	5.250 133.4	3.46 1.57
1 ⅝ 36	2.375 60.3	5.750 146.1	4.81 2.18
1 ¾ 46	3.000 76.2	8.500 215.9	11.26 5.11
2 ½ 65	4.250 108.0	10.000 254.0	25.04 11.36
3 75	5.000 127.0	12.000 308.0	42.60 19.32

Grade 150 Bar					
Nominal Diameter in (mm)	A in (mm)	B in (mm)	C in (mm)	Weight lbs (kg)	
				Full	Jam
1 26	1.750 44.5	2.000 50.8	0.500 12.7	1.11 .50	0.28 0.13
1 ¼ 32	2.250 57.2	2.500 63.5	0.625 15.9	2.34 1.06	0.47 0.21
1 ⅝ 36	2.500 63.5	2.750 69.9	0.750 19.1	3.21 1.46	1.17 0.53
1 ¾ 46	3.000 76.2	3.500 88.9	1.250 31.8	5.56 2.52	1.19 0.54
2 ½ 65	4.000 101.6	4.750 120.7	1.000 25.4	15.02 6.81	3.163 1.43
3* 75	5.000 127.0	6.125 155.6	2.000 50.8	21.30 9.66	5.30 2.40

*Round collar nut with flats with outside diameter of 5" (127mm).

Threaded Bar and Accessories

Hardened Washers

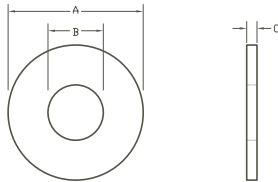

Round Beveled Washers

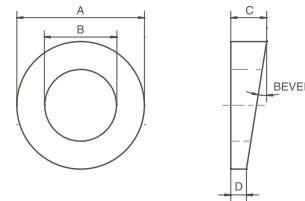

Grade 75 Bar				
Bar Designation	A in (mm)	B in (mm)	C in (mm)	Weight lbs (kg)
#8	2.250 57.2	1.380 34.9	0.150 3.8	0.11 0.05
#9	2.250 57.2	1.500 38.1	0.150 3.8	0.13 0.06
#10	2.250 57.2	1.630 41.3	0.150 3.8	0.20 0.09
#11	3.000 76.2	1.750 44.5	0.220 5.6	0.20 0.09
#14	3.375 85.7	2.130 54.0	0.280 7.1	0.30 0.14
#18	4.600 116.8	2.630 66.7	0.280 7.1	0.65 0.29
#20	5.000 127.0	3.000 76.2	0.280 7.1	0.90 0.41
#24	5.500 139.7	3.500 88.9	0.280 7.1	1.70 0.77
#28	6.000 152.4	4.000 101.6	0.313 8.0	1.85 0.84

Grade 75 Bar						
Bar Designation	A in (mm)	B in (mm)	C in (mm)	D in (mm)	Bevel degrees	Weight lbs (kg)
#8	1.75 44.5	1.25 31.8	0.270 6.9	0.188 4.8	15	1.70 0.77
#9	2.625 66.7	1.25 31.8	0.80 20.3	0.34 8.6	15	1.80 0.82
#10	2.75 44.5	1.63 41.4	1.64 41.7	0.23 5.8	15	2.00 0.91
#11	3.09 78.4	1.75 44.5	1.64 41.7	0.23 5.8	15	2.00 0.91
#14	4.00 101.6	2.13 54.1	1.64 41.7	0.23 10.9	15	2.40 1.09
#18	4.60 116.8	2.63 66.7	1.25 31.8	0.37 9.4	10	2.50 1.13
#20	5.00 127.0	3.00 76.2	1.75 44.5	0.43 10.9	10	2.80 1.27
#24	7.50 190.5	3.50 88.9	1.75 44.5	0.43 10.9	10	4.30 1.95
#28	8.00 203.2	4.00 101.6	2.25 57.2	0.84 21.3	10	5.40 2.45

Grade 150 Bar				
Nominal Diameter in (mm)	A in (mm)	B in (mm)	C in (mm)	Weight lbs (kg)
1 26	2.250 57.2	1.250 31.8	0.156 4.0	0.14 0.06
1 ¼ 32	2.750 69.9	1.500 38.1	0.156 4.0	0.21 0.10
1 ½ 36	3.000 76.2	1.625 41.3	0.156 4.0	0.28 0.13
1 ¾ 46	3.750 95.3	2.130 54.1	0.218 5.5	0.34 0.15
2 ½ 65	5.000 127.0	2.875 73.0	0.218 5.5	0.94 0.43
3 75	6.000 152.4	3.375 85.7	0.313 8.0	1.06 0.48

Grade 150 Bar						
Nominal Diameter in (mm)	A in (mm)	B in (mm)	C in (mm)	D in (mm)	Bevel degrees	Weight lbs (kg)
1 26	2.625 66.7	1.25 31.8	1.64 41.7	0.23 5.8	15	0.60 0.27
1 ¼ 32	2.750 69.9	1.63 41.4	1.64 41.7	0.23 9.4	15	0.61 0.28
1 ½ 36	3.090 78.5	1.75 44.5	1.64 41.7	0.23 10.9	15	0.85 0.39
1 ¾ 46	4.000 101.6	2.13 54.1	1.64 41.7	0.23 10.9	15	1.75 0.79
2 ½ 65	5.000 127.0	3.00 76.2	1.75 44.5	0.43 10.9	10	2.77 1.26
3 75	8.000 203.2	3.50 88.9	1.75 44.5	0.43 10.9	10	4.30 1.95

Threaded Bar and Accessories

Bearing Plates

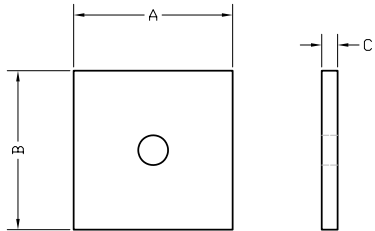

Bearing plate dimensions reflect typical sizes.
Actual design criteria should be used for specific plate sizing.

Grade 75 Bar				
Bar Designation	A in (mm)	B in (mm)	C in (mm)	Weight lbs (kg)
#8	8 203.20	8 203.20	¾ 19.05	13.40 6.08
#9	8 203.20	8 203.20	¾ 19.05	13.35 6.06
#10	8 203.20	8 203.20	1 25.40	17.73 8.04
#11	10 254.00	10 254.00	1 25.40	27.86 12.64
#14	10 254.00	10 254.00	1 ½ 38.10	41.37 18.76
#18	10 254.00	10 254.00	2 50.80	54.21 24.59
#20	10 254.00	10 254.00	2 ½ 63.50	67.06 30.42
#24	10 254.00	10 254.00	2 ½ 63.50	65.46 29.69
#28	12 304.80	12 304.80	2 ¾ 69.85	104.26 47.29

Grade 150 Bar				
Nominal Diameter in (mm)	A in (mm)	B in (mm)	C in (mm)	Weight lbs (kg)
1 26	6 152.4	6 152.4	1 ¼ 31.8	12.76 5.79
1 ¼ 32	7 177.8	7 177.8	1 ½ 38.1	20.84 9.45
1 ¾ 36	8 203.2	8 203.2	1 ¾ 44.5	31.76 14.41
1 ¾ 46	9 228.6	9 228.6	1 ¾ 44.5	40.20 18.23
2 ½ 65	10 254.0	10 254.0	2 ½ 63.5	70.89 32.16
3 75	12 304.8	12 304.8	2 ¾ 69.9	112.31 50.94

Corrosion Protection Options

All threaded bars can be supplied with a protective smooth-walled PVC tube. While the standard PVC tube is 0.035 inch thick, other options are available upon request.

The following additional corrosion protection options are available for all threaded bars:

Single Corrosion Protection (SCP)

Double Corrosion Protection (DCP) Options

- Encapsulating: Grease or Grout
- Epoxy Coating
- Galvanizing
- Painting
- Plating
- Taping
- Teflon Coating

Oversized accessories are provided to accommodate galvanized and coated bars.

Micropile

Recycled Content: n/a*
Recyclable: 100%

Micropiles were first developed in Italy in the 1950's to retrofit the foundation of structures damaged during World War II. The combination of small size and vibration-free installation made them ideal for foundation repair in old basements. A micropile is a short piece of threaded pipe, usually less than 12" in diameter. Since the lengths of pipe are threaded together as the pile is drilled into the ground, the clearance needed to install the pile is reduced.

To increase load-carrying capacity, a micropile is grouted in place using a variety of methods. The bond strength between pile and soil is improved with increases in grout pressure. The addition of smaller diameter casing or high strength threaded bar to the inside of the pile also increases its structural strength.

Pipe lengths are often made from secondary pipe, which is also known as oil country reject. Although secondary pipe is rejected for use in wells, because of extremely high tolerances, it is a high quality pipe that is perfectly suitable for structural applications.

Applications of Micropile

Some common uses for micropile are seismic retrofit for bridges and buildings, deep foundations on projects with low headroom or space limitations, vibration-less installation, and slope stability on projects with access restrictions.

* Due to the nature of sourcing micropile pipe, the percent of recycled content is not verifiable.

Micropile

Threaded Casing

Outside Diameter	Thickness	Inside Diameter	Weight	Cross Sectional Area	Total Area of Shaft	Internal Volume	External Surface Area	Moment of Inertia	Section Modulus
5.500 139.7	0.415 10.5	4.670 118.6	22.56 33.5	6.63 42.77	23.76 153.3	0.12 0.011	1.44 0.44	21.57 897.8	7.84 128.5
5.500 139.7	0.500 12.7	4.500 114.3	26.73 39.8	7.85 50.67	23.76 153.3	0.11 0.010	1.44 0.44	24.79 1032	9.01 147.7
7.000 177.8	0.408 10.4	6.184 157.1	28.75 42.8	8.45 54.51	38.48 248.3	0.21 0.019	1.83 0.56	46.07 1918	13.16 215.7
7.000 177.8	0.453 11.5	6.094 154.8	31.70 47.2	9.32 60.11	38.48 248.3	0.20 0.019	1.83 0.56	50.16 2088	14.33 234.9
7.625 193.7	0.430 10.9	6.765 171.8	33.07 49.2	9.72 62.71	45.66 294.6	0.25 0.023	2.00 0.61	63.12 2627	16.56 271.3
7.625 193.7	0.500 12.7	6.625 168.3	38.08 56.7	11.19 72.21	45.66 294.6	0.24 0.022	2.00 0.61	71.37 2971	18.72 306.8
9.625 244.5	0.545 13.8	8.535 216.8	52.90 78.7	15.55 100.3	72.76 469.4	0.40 0.037	2.52 0.77	160.80 6693	33.41 547.5
9.625 244.5	0.650 16.510	8.325 211.455	62.36 92.8	18.33 118.24	72.76 469.42	0.38 0.04	2.52 0.77	185.50 7721.18	38.55 631.65
10.750 273.1	0.500 12.7	9.750 247.7	54.79 81.5	16.10 103.9	90.76 585.6	0.52 0.048	2.81 0.86	211.95 8822	39.43 646.2
11.875 301.6	0.582 14.8	10.711 272.1	70.26 104.6	20.65 133.2	110.75 714.5	0.63 0.058	3.11 0.95	330.04 13737	55.59 910.9
13.375 339.7	0.480 12.2	12.415 315.3	66.17 98.5	19.45 125.5	140.50 906.5	0.84 0.078	3.50 1.07	404.73 16846	60.52 991.8

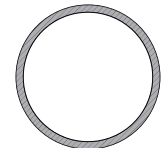

Cross Sectional Area

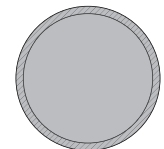

Total Area of Shaft

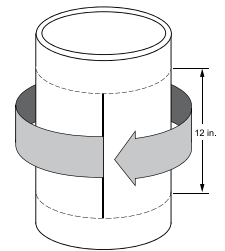

External Surface Area



Starter casing available with carbide button or carbide sinter (ictology) bits



Female and male casing cut and bundled to specifications



Subs available to fit all sizes of casing

Micropile

Casing Accessories

Skyline Steel's GeoStructural Group is positioned to deliver complete accessory packages with your threaded casing. We understand the urgency of your project and stock a wide range of casing accessories for immediate delivery.

J-Teeth	Grout Heads	Duplex Adapters
Ring Bits	Shear Rings	Flange Adapters
Casing Shoes	Protective Caps	Casing Crossover Subs

Tooling Items

Custom machining is available for duplex and flange adapters to match casing, drill, and drill system requirements. We can also fabricate crossover subs to fit any existing tooling items.

Skyline Steel offers the following tooling items for the installation of micropile casing:

Air Swivels	API Crossover Subs	API Drill Rods (2 3/8 in to 6 5/8 in)
Breakout Wrenches	Casing Crowns	Cushion Subs
Diverter Heads	Downhole Hammers	Downhole Hammer Bits
Drag Bits	Floating Subs	Flushing Heads
Grout Swivels	Ictology Bits	Stabilizers
Tricone Bits		



Casing accessories include duplex and flange adapters



Downhole hammers and bits are available in various sizes and shank configurations



API drill rods and casing subs are typical tooling items

Structural Sections

Recycled Content: 100%

Recyclable: 100%

Skyline Steel takes great pride in providing a wide range of structural sections from several different mills. All sections (including jumbo beams and columns) found in the American Institute of Steel Construction (AISC) manual are available.

Applications of Structural Sections

Foundation contractors utilize beams and columns for bracing systems of cofferdams, beam and lagging walls, and secant pile walls. Channel and miscellaneous channel sections are often used to make walers for anchorage systems and caps for sheet pile walls.

Structural Sections

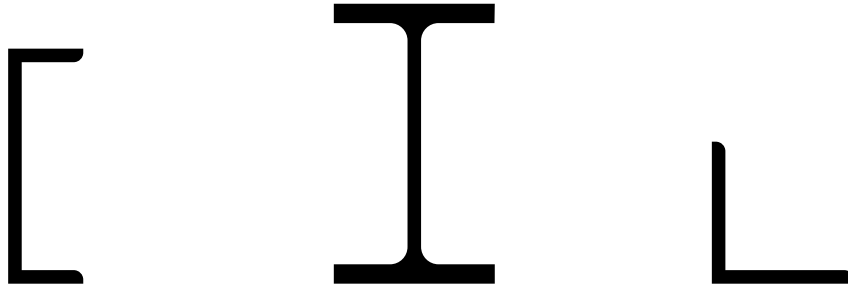

BEAM Available Steel Grades								
AMERICAN			CANADIAN			EUROPEAN*		
ASTM	YIELD STRENGTH		CSA G40.21	YIELD STRENGTH		EN 10025 & EN 10113	YIELD STRENGTH	
	(ksi)	(MPa)		(ksi)	(MPa)		(ksi)	(MPa)
A 36	36	250	Grade 350 W	50	350	S 235	34	235
A 572 Grade 50	50	345				S 275	40	275
A 588	50	345				S 355	51	355
A 709	50	345				S 460 HISTAR	67	460
A 913	50	345						
A 913	65	450						
A 992	50	345						

*HISTAR only available in some sizes.

Delivery Conditions & Tolerances

ASTM A 6	
Mass	± 2.5%
Depth	± 0.125 inches
Length	30 feet and Under Over 30 Feet
Beams W 24 and Under	± 0.375 inches + (0.375 inches + (Length - 30) / 80 -0.375 inches
Beams Over W 24	± 0.5 inches + (0.5 inches + (Length - 30) / 80 -0.375 inches
Flanges out of Square	
Beams W 12 and Under	≤ 0.25 inches
Beams Over W 12	≤ 0.3125 inches
Web off Center	≤ 0.1875 inches
Greatest Depth over Theoretical	≤ 0.25 inches
Camber and Sweep	(0.125 in) * (Length / 10)
Camber and Sweep for Columns*	
45 Feet and Under	(0.125 in) * (Length / 10) but not over 0.375 inches
Over 45 Feet	(0.375 in) + (0.125 in * (Length - 45) / 10)

*W 8 x 31 and heavier, W 10 x 49 and heavier, W 12 x 65 and heavier, and W 14 x 90 and heavier order as columns. If other sections are ordered as columns, the tolerances are subject to negotiation with manufacturer.

Structural Sections

CHANNEL Available Steel Grades								
AMERICAN			CANADIAN			EUROPEAN		
ASTM	YIELD STRENGTH		CSA G40.21	YIELD STRENGTH		EN 10248	YIELD STRENGTH	
	(ksi)	(MPa)		(ksi)	(MPa)		(ksi)	(MPa)
A 36	36	250	Grade 350 W	50	350	S 235 GP	34	235
A 572 Grade 50	50	345				S 355 GP	51	355
A 572 Grade 60	60	415						
A 588	50	345						
A 242	50	345						

Delivery Conditions & Tolerances

Mass	± 2.5%						
Depth	3 to 7 in		7 to 14 in			Over 14 in	
	+ 0.9375 in	- 0.0625 in	+ 0.125 in	- 0.9375 in	+ 0.1875 in	- 0.125	
Length	5 to 10 ft		10 to 20 ft		20 to 30 ft		30 to 40 ft
	+ 1.0 in	+ 1.5 in	+ 1.75 in	+ 2.25 in	+ 2.75 in	+ 2.75 in	
Flange Width	3 to 7 in		7 to 14 in			Over 14 in	
	± 0.125 in		+ 0.125 in	- 0.9375 in	+ 0.125 in	- 0.1875	
Flanges out of Square	≤ 0.03125 in						
Camber	(0.125 in) * (Length / 5)						
Sweep	Subject to negotiation with manufacturer						

ANGLE Available Steel Grades								
AMERICAN			CANADIAN			EUROPEAN		
ASTM	YIELD STRENGTH		CSA G40.21	YIELD STRENGTH		EN 10248	YIELD STRENGTH	
	(ksi)	(MPa)		(ksi)	(MPa)		(ksi)	(MPa)
A 36	36	250	Grade 350 W	50	350	S 235	34	235
A 572 Grade 50	50	345				S 355	51	355
A 572 Grade 60	60	415						
A 588	50	345						
A 242	50	345						

Delivery Conditions & Tolerances

Mass	± 2.5%						
Length	5 to 10 ft		10 to 20 ft		20 to 30 ft		30 to 40 ft
	+ 1.0 in	+ 1.5 in	+ 1.75 in	+ 2.25 in	+ 2.75 in	+ 2.75 in	
Leg Length*	1 to 2 in		2 to 3 in		3 to 4 in		4 to 6 in
	± 0.046875 in		± 0.0625 in		+ 0.125 in		- 0.09375 in
Flanges out of Square	± 1.5 degrees						
Thickness	≤ 0.1875 in		0.1875 in to 0.375 in			Over 0.375 in	
1 to 2 in.	± 0.010 in		± 0.010 in			± 0.012 in.	
2 to 3 in.	± 0.012 in		± 0.015 in			± 0.015 in.	
Camber	(0.125 in) * (Length / 5)						
Sweep	Subject to negotiation with manufacturer						

* Longer leg length determines classification.

Maximum Rolled Lengths**

All Sections	60 feet
Most Sections	85 feet
Some Sections	120 feet

** Longer lengths may be possible upon request.



Find the district sales office that's most convenient for you:

North America

United States

Birmingham, AL
205-262-9909

Denver, CO
303-629-9253

Duluth, GA
770-242-9007

Earth City, MO
314-739-1303

Exeter, RI
401-667-5970

Fife, WA
253-922-2727

Houston, TX
281-992-4000

Mandeville, LA
985-624-3620

Middletown, NJ
732-671-5900

Orlando, FL
407-622-6001

Pittsburgh, PA
412-437-1100

Sacramento, CA
916-463-0105

Springfield, VA
703-978-2500

United States (cont'd)

Taunton, MA
508-821-4700

Tinley Park, IL
708-444-0999

West Chester, OH
513-777-7039

Specialty Pipe Sales

Cartersville, GA
866-736-PIPE (7473)

México

Querétaro
+52-442-218-5511

Caribbean

Orlando, FL
407-622-6001

Canada

St. Albert, AB
780-460-8363

St. Bruno, QC
450-461-6366

Port Moody, BC
604-461-6367

Central America

Panamá City, Panamá
507-392-4800

South America

Argentina

Buenos Aires
+54-11-4719-8516

Brazil

Belém
+55-91-3665-2052

Belo Horizonte
+55-31-3379-6045

Curitiba
+55-41-2112-4011

Fortaleza
+55-85-3499-7012

Rio de Janeiro
+55-21-2797-2928

São Paulo
+55-11-3636-6518

Chile

Santiago
+56-2-949-2800

Colombia

Bogotá
+57-1-623-4022

Perú

Lima
+51-1-421-4364

For technical questions and engineering support, please contact us via our technical hotline at:

1-866-875-9546 or email us at: engineering@skylinesteel.com.

Corporate Headquarters 8 Woodhollow Road Parsippany, NJ 07054

Phone: 973-428-6100 Fax: 973-428-7399 Toll-Free: 1-888-450-4330 www.skylinesteel.com info@skylinesteel.com

About Skyline Steel

A premier steel foundation supplier serving the US, Canada, Mexico, Central America, Caribbean and South American markets, Skyline Steel is a wholly-owned subsidiary of ArcelorMittal, the world's leading steel company with operations in more than 60 countries.

About ArcelorMittal Projects (AMP):

The projects division of ArcelorMittal provides complete and customized steel solutions for its partners. In addition to an easily accessible worldwide network of mills, ArcelorMittal Projects offers its customers a one-stop show through: its own production and processing facilities; project management and pre-fabrication services; and, engineering support.