



PilePro

**The World Leader in
Sheet Piling Connections**

Also including



WADIT

PilePro.com

For Larssen
Page 7

For Ball & Socket
Page 25

For Flat Sheet
Page 47

For Cold Formed
Page 61

For Pipe Sheet Pile
Page 75



Table of Contents

About PilePro	SWC	3
Page 3	Any-Z	3
	O-Pile	4
	iSheetPile	4
	WADIT	5

For Larssen Page 7

Any-Z	11	Omega Tee	15	P-Tank I / P-Tank II	20
V 20	12	AZ Tee	16	V 22	22
AZ 90	13	PL	17	Tank	23
Omega	14	B-Tank I / B-Tank II.....	18		

For Ball & Socket Page 25

Any-Z	28	PZT-S	33	WOM/WOF	40
PZ 90	29	Joker	34	WOM-XL/WOF-XL	42
Colt	30	Bullhead	35	WOM-XXL/WOF-XXL	44
Cobra	31	BBS-M/BBS-F	36		
PZ Tee	32	PBS-M/PBS-F	38		

For Flat Sheet Page 47

120 Flat Sheet.....	51	SWC 60 A/B	54	SWC	58
SWC 30 A/B	52	SWC 90 A/B.....	56		

For Cold Formed Page 61

CFC 90	64	Any-Z.....	67	CF Weld-on.....	72
CF 90	65	BCF I/II.....	68		
CF Tee.....	66	PCF II/I.....	70		

For Pipe Sheet Pile Page 75

WOM-XL/WOF-XL	80	WOM-XXL/WOF-XXL	82	WOM-S/WOF-S	84
---------------------	----	-----------------------	----	-------------------	----



About PilePro®

The PilePro core of companies uniquely integrates every facet of the SSP industry, all in one place.

The PilePro Group



iSheetPile

WADIT

The Industry's Foremost Innovator in Sheet Piling Connections

PilePro transformed the sheet piling corner and junction pile business through the introduction of innovative extruded steel connectors. The foundation construction industry quickly recognized the advantages of the PilePro extruded connectors, namely: their light weight and ease of use; the elimination of costly fabrication; and, specifically, removing welded connections that are susceptible to increased rates of corrosion.

PilePro's innovation in connector design has led to the development of sheet piling solutions that lead the market.

1. The use of the SWC flat sheet pile connector has simplified the Open Cell construction design method and removed concerns about corrosion on the highly stressed piles. Now, with the introduction of the 120 Flat Sheet, we have further simplified the installation process.



Photograph © PND Engineers, Inc.

2. New for 2013: Introducing Any-Z. The Any-Z combines the functionality of a number of Z connectors. The Any-Z helps reduce the need for keeping a number of different connectors on site. It also gives on-demand installation change capability.

This connector works with all AZ, cold formed, and Ball & Socket sheet piles. Also, it is a transition from AZ to cold formed, and from cold formed to PZ/PZC.

Any-Z gives unmatched flexibility in a single connector, enabling sheet pile wall components to be extended at an angle, either as a corner section with 90°, or with a wider angle of between 90° and 180°.

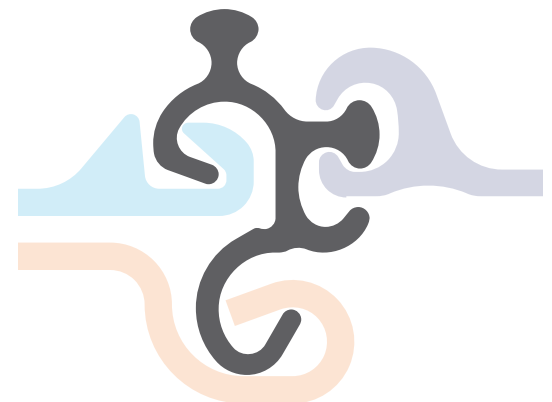

Any-Z works with all kinds of sheet pile interlocks.



3. The introduction of the WOM/WOF-XL connector has enabled designers and contractors to pursue the use of the high capacity and highly efficient Pipe Sheet Pile system. Pipe to pipe is not new; however, previous methods of trying to connect the pipe piles have been highly problematic, involving difficult welding attachments, resulting in connections that have been prone to declutching during driving and, thus, in need of grouting. The WOM/WOF-XL has solved these issues with a high capacity and simple-to-install connection.

O-Pile® is the brand name for the high capacity Pipe to Pipe wall concept using the WOM/WOF-XL or WOM/WOF-XXL connectors, and a franchise opportunity from PilePro to interested pipe producers or sheet piling distributors interested in becoming a PilePro partner company and having exclusive regional representation for the Pipe to Pipe wall system.



4. PilePro's innovation extends beyond product development, with the launch of the iSheetPile® on-line platform. In essence, iSheetPile is an easy-to-use yet sophisticated software program that gives the foundation construction industry the ability to research sheet pile systems – whether sheet pile, Combi-walls with pipe or king piles, or Pipe to Pipe – from manufacturers all over the world, in one location.

The key aim is to ensure that the user can find and configure the most efficient sheet pile solution from over 180,000+ possible options. Hopefully, the process will guide the user to a solution in steel rather than concrete.



iSheetPile



The iSheetPile.com home page.

5. Why trust imitations? WADIT® is the *real* deal.

WADIT is a globally proven sheet piling interlock sealant that can be used with all types of hot rolled and cold formed sheet piling interlocks in every possible environment (tropical to arctic) and particularly in marine conditions.

WADIT



If your sheet piling project involves cofferdams, dewatering, cutoff walls for site remediation, or any application where water leakage through the wall presents a problem, WADIT is the solution.

Tests have demonstrated that leakage through sheet pile walls is reduced up to 95% when interlock sealants are used, and sealed joint sheet pile cutoff walls are anywhere from 100 to 10,000 times more effective as groundwater flow barriers than unsealed interlock walls. (Sealed walls typically exhibit hydraulic conductivity in the 10⁻⁷ to 10⁻¹⁰ cm/sec range.)

WADIT is the smart choice sealant from a cost, safety and convenience standpoint.

Please call PilePro at 866-666-7453 to find an authorized WADIT distributor in your area and/or to receive a quote for PilePro to carry out the WADIT installation. PilePro has trained and tested WADIT installation crews with certified equipment that can quickly deploy to your mill location or project site to install WADIT into any sheet pile type or interlock.

PilePro Connectors

PilePro manufactures corners and connectors for all types of sheet pile used around the world. The connectors are made to highly stringent standards that form precise, seamless connections between steel sheet pile and other support systems, such as H-Beam, I-Beam and Pipes/Tubes.

These connectors are often modular in nature and come to the contractor or end user as a “ready-to-install” component. In addition to ready stock in our main markets, PilePro also offers specialty made-to-order connectors that form high-value engineering solutions.

PilePro connectors have effectively rendered fabricating corners and other connection processes in steel piling construction projects a relic of the past.

PilePro connectors are rapidly emerging as the “go-to” product in port, cofferdam, and other construction projects around the world.

Reliable

- PilePro corner connectors offer a one-piece construction that does not rely on a single vertical weld seam. There is never a risk of “unzipping” at the corner or junction pile.
- PilePro connectors are interlocked and attached to the sheet piling; thus, single-unit integrity of the steel wall unit is always maintained.
- Durability: The risk of preferential weld corrosion that is common with fabricated connectors is eliminated with PilePro’s extruded shapes.

Flexible

- Design: Superior design means PilePro connectors have greater flexibility within the interlock – typically 20° to 30° of swing versus the 2° to 5° of swing found in most sheet pile interlocks.
- Less expense: PilePro connectors provide superior cornering and connection solutions on a Customary Quick Delivery (CQD) basis through an efficient logistics network. Through this network, products may be delivered directly to the job site.

For Larssen

The Larssen connector range includes the multi-use Any-Z along with two-way and three-way corners, junction piles, and T connections. Connectors are also included for transitions, combined sheet pile walls with pipe piles, wide flange beams, and Peiner beams.

Angle rotation and interlock flexibility figures shown on following pages may vary subject to product rolling tolerances.

Any-Z	11	PL	17
V 20	12	B-Tank I/B-Tank II	18
AZ 90	13	P-Tank I/P-Tank II	20
Omega	14	V 22	22
Omega Tee	15	Tank	23
AZ Tee	16		

System Overview

Don't see the best solution?
Call us at
(866) 666-7453

For Larsen AZ Sheet Pile

Any-Z, p. 11

For 90° corners ($\pm 60^\circ$)

Omega Tee, p. 15

For T-corners, and 90° corners

AZ Tee, p. 16

For T-corners and 90° corners

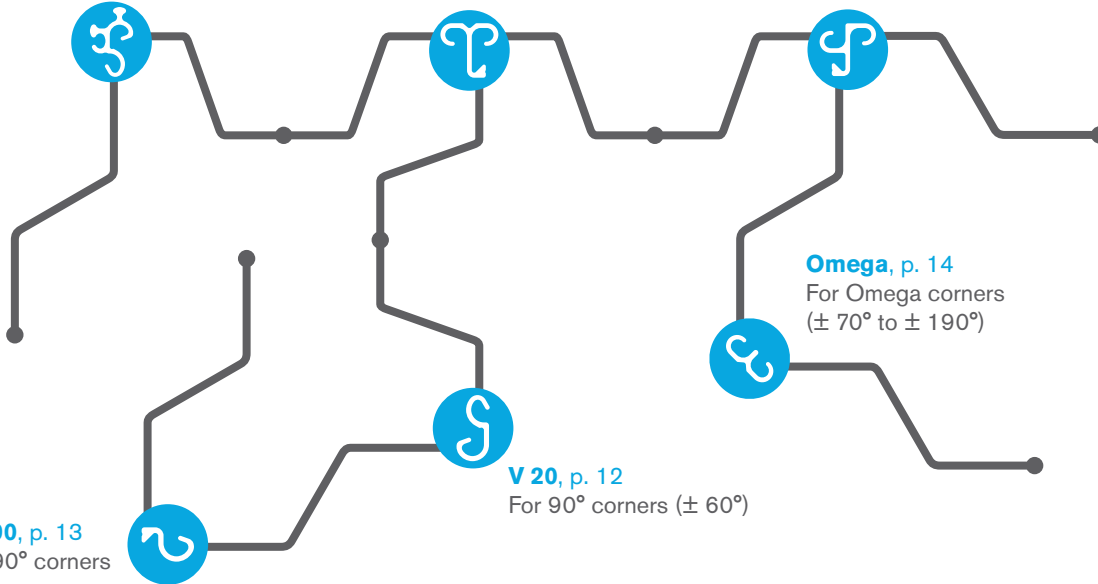

AZ 90, p. 13

For 90° corners

V 20, p. 12

For 90° corners ($\pm 60^\circ$)

Omega, p. 14

For Omega corners ($\pm 70^\circ$ to $\pm 190^\circ$)

For Larsen U Sheet Pile

Omega, p. 16

For omega corners ($\pm 70^\circ$ to $\pm 190^\circ$)

Omega Tee, p. 17

For T-corners, and 90° corners

V 20, p. 14

For 90° corners ($\pm 60^\circ$)

AZ Tee, p. 18

For T-corners and 90° corners

AZ 90, p. 15

For 90° corners

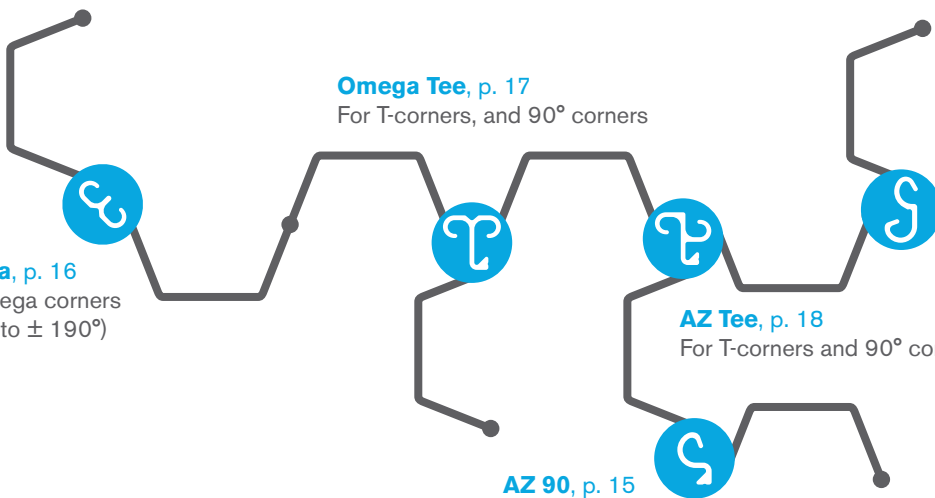

We have the right connector for all of your Larssen sheet pile projects.

Having trouble finding the best solution? Call us at (866) 666-7453 or email sales@pilepro.com and we will find the solution with you.

Combined Sheet Piles

B-Tank I/II, p. 18/19

For ultra-sturdy combined sheet pile walls (Peiner beams)

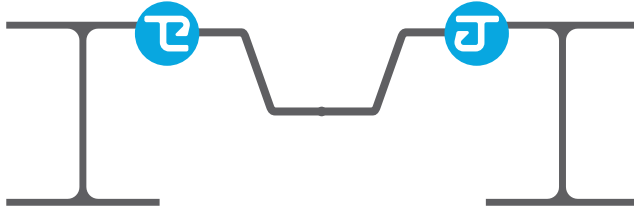

PL, p. 17

For combined sheet pile walls (Peiner beams)

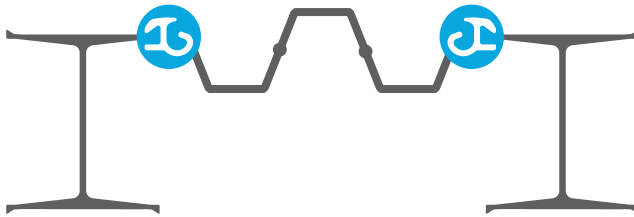

P-Tank I/II, p. 21

For ultra-sturdy combined sheet pile walls (Peiner beams)

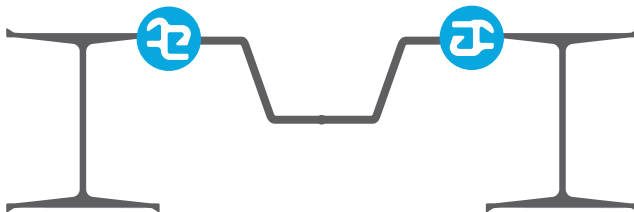

Tank, p. 23

For ultra-sturdy combined sheet pile walls (pipes)



V 22, p. 22

For combined sheet pile walls (pipes)



Transition Piles

Any-Z, p. 11

For PZ/PZC ↔ AZ/Larssen transitions

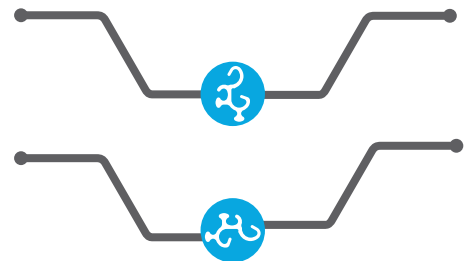

For AZ/Larssen ↔ Cold formed transitions



V 20, p. 12

For AZ/Larssen ↔ Cold formed transitions





Flexibility

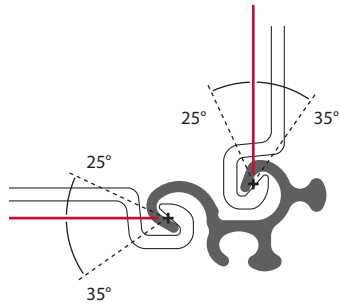

Dimensions

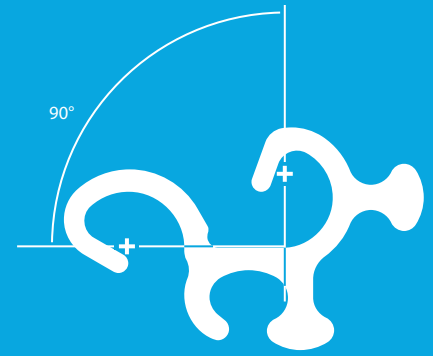
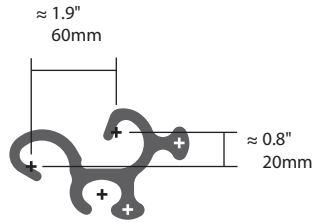

Any-Z[®]

For 90° corners,
for PZ/PZC ↔ AZ/Larssen,
for PZ/PZC ↔ CF/Cold formed

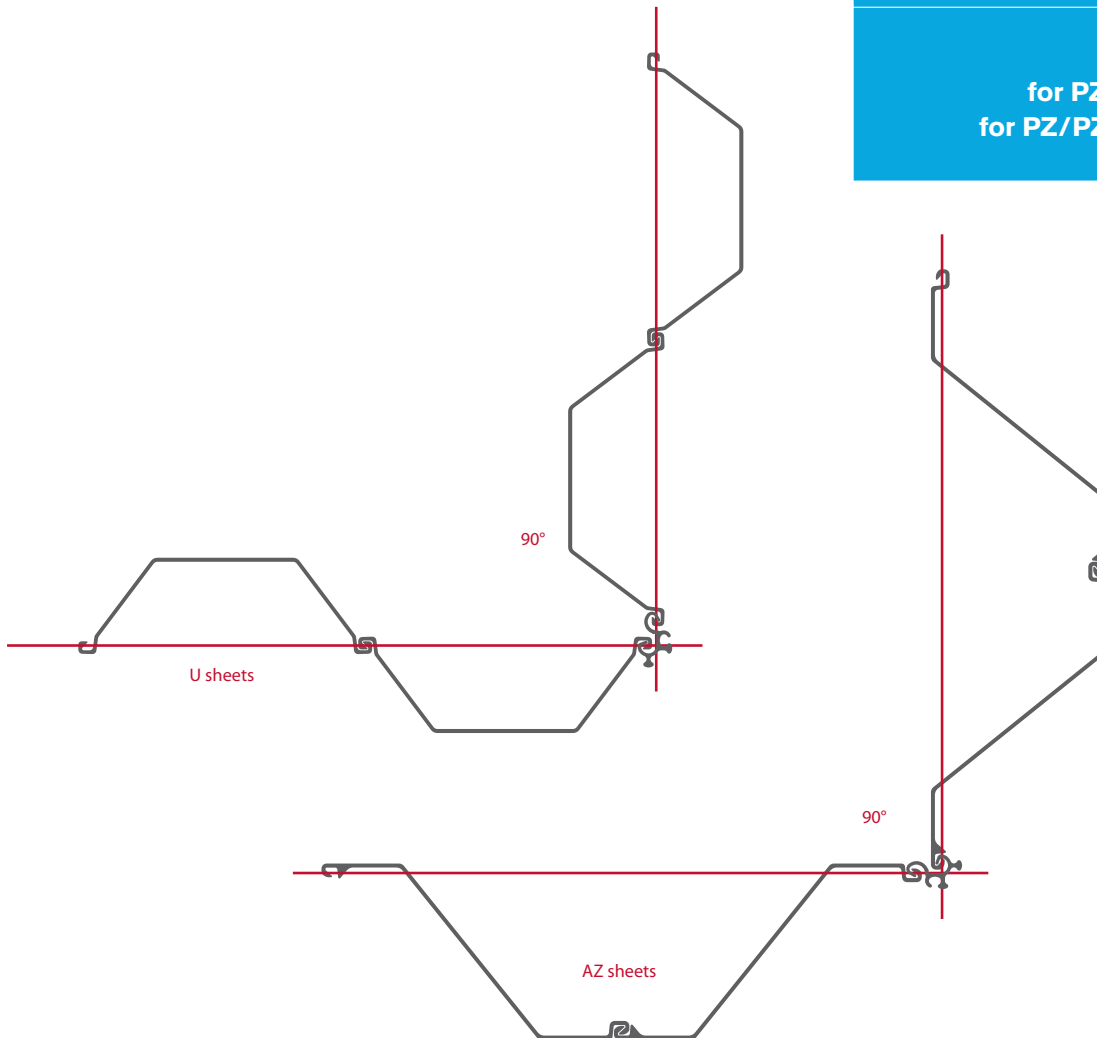

For additional details:
pilepro.com/anyz

WEIGHT:
~14.6 lb/ft
~ 21.7 kg/m

TYPICAL STEEL GRADES:
ASTM A572 Gr. 50/60
ASTM A690

Other steel grades available upon request.



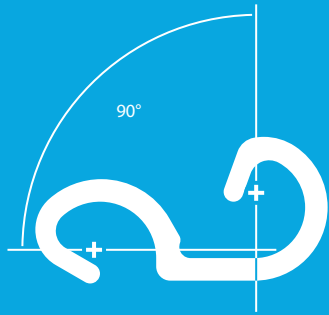

V 20

For 90° corners (± 60°),
For Larsen ↔ Cold formed
transitions

Flexibility

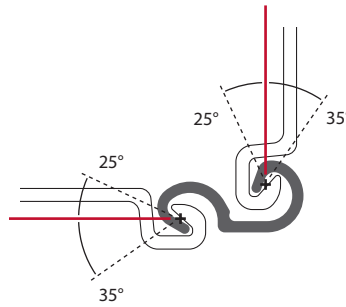

Dimensions

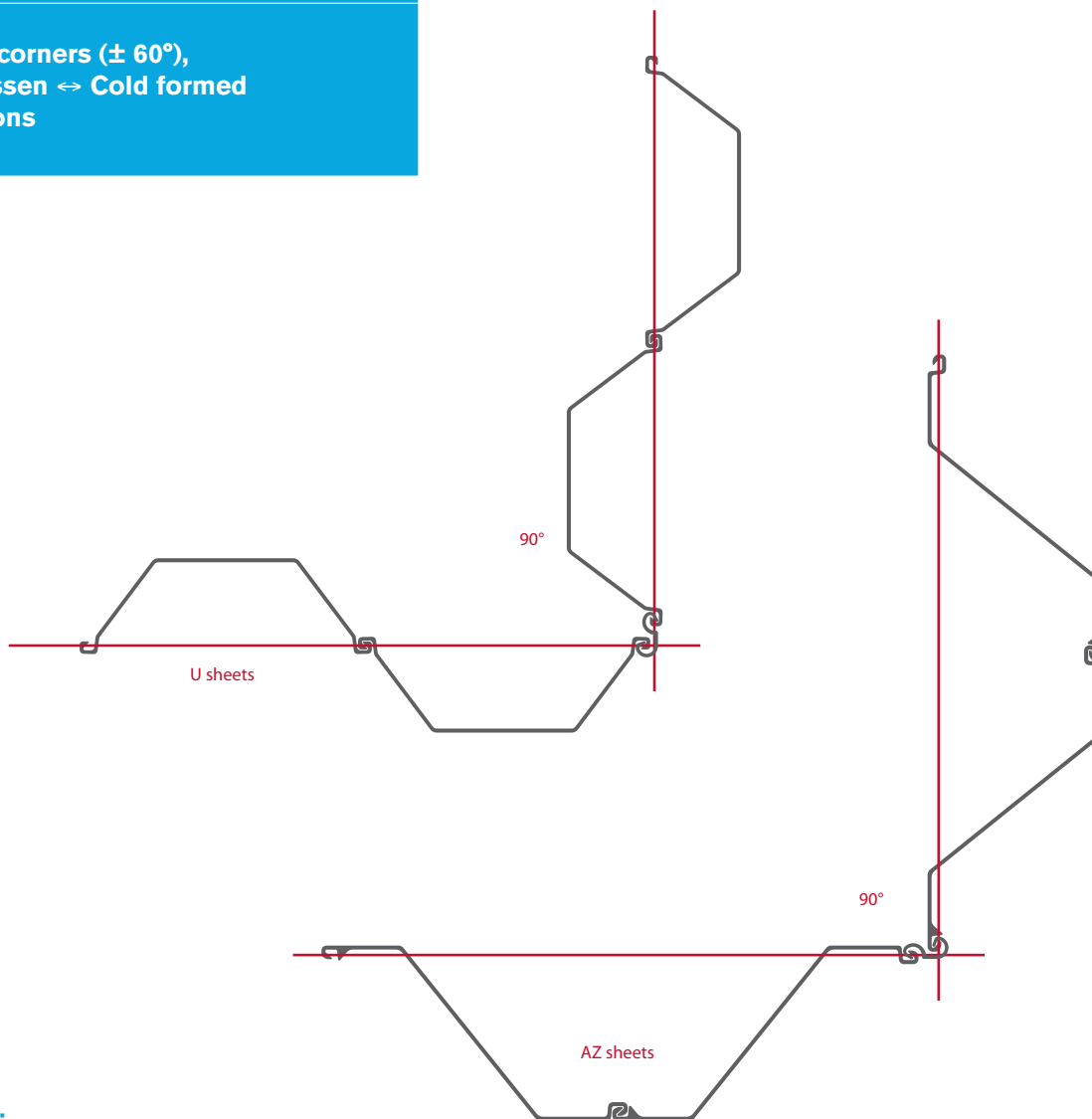
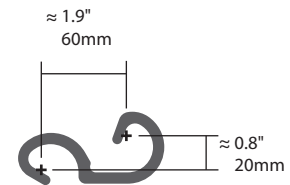

WEIGHT:
~ 8.9 lb/ft
~ 13.2 kg/m

STEEL GRADE:
ASTM A572 Gr. 50/60
ASTM A690 MARINER Steel



For additional details:
pilepro.com/v20



Flexibility

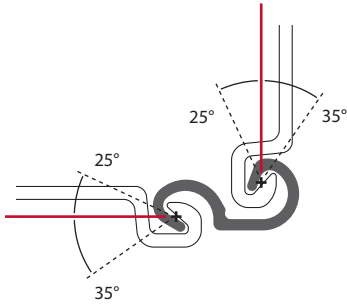

Dimensions

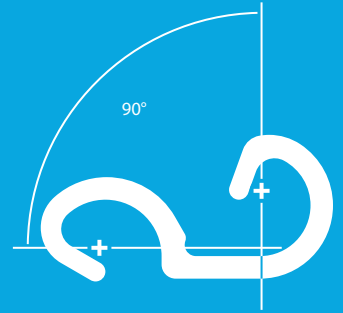
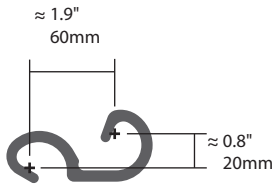

AZ 90

For 90° corners

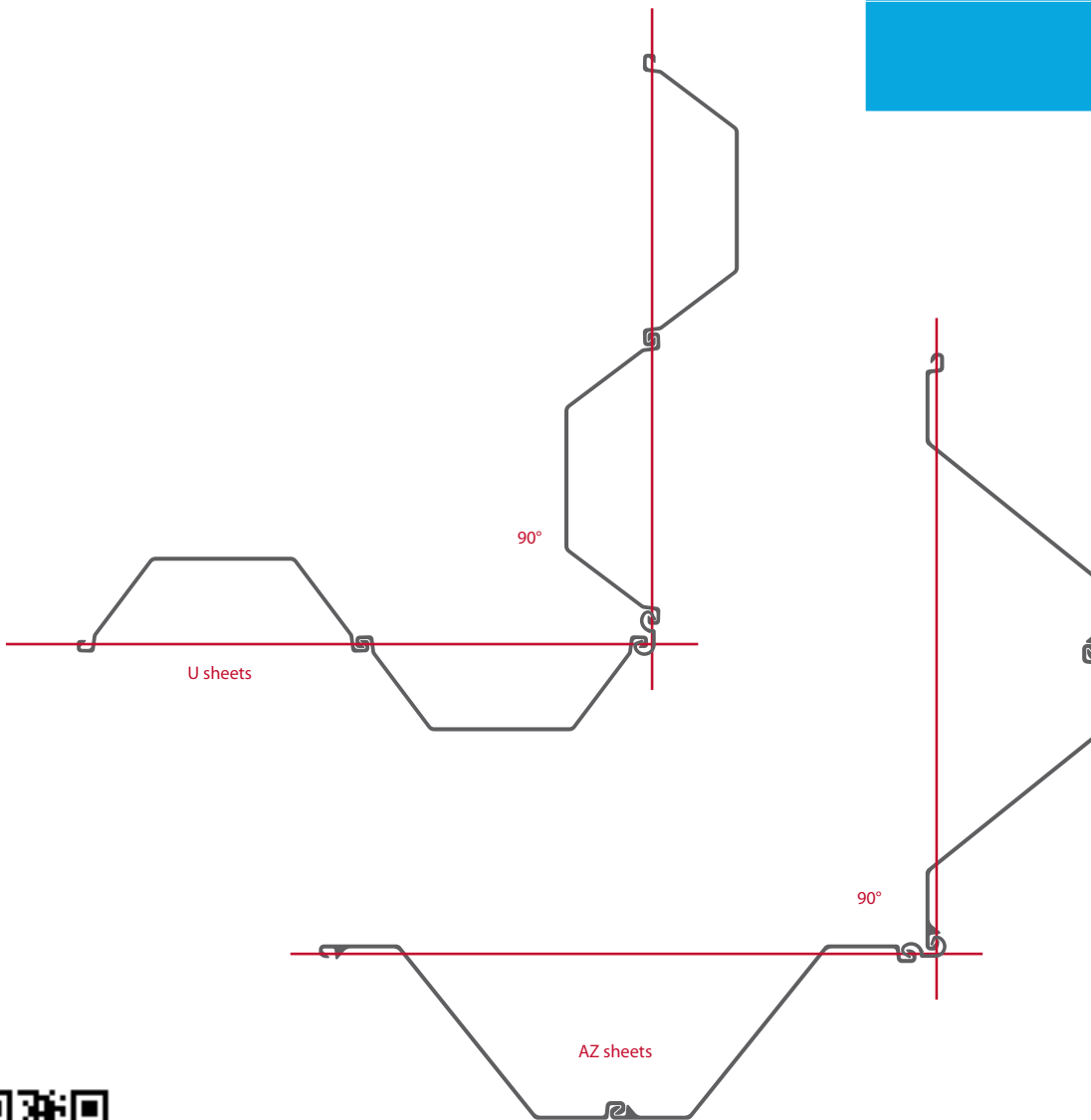

For additional details:
pilepro.com/v20

WEIGHT:
~ 8.9 lb/ft
~ 13.2 kg/m

STEEL GRADE:
ASTM A572 Gr. 50/60
ASTM A690 MARINER Steel



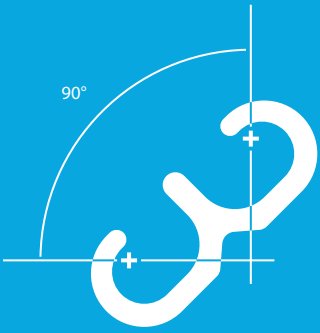

Omega

For Omega corners
(± 70° to ± 190°)

Flexibility

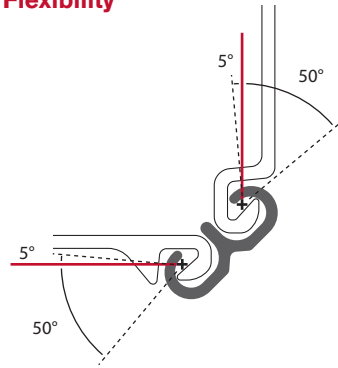

Dimensions

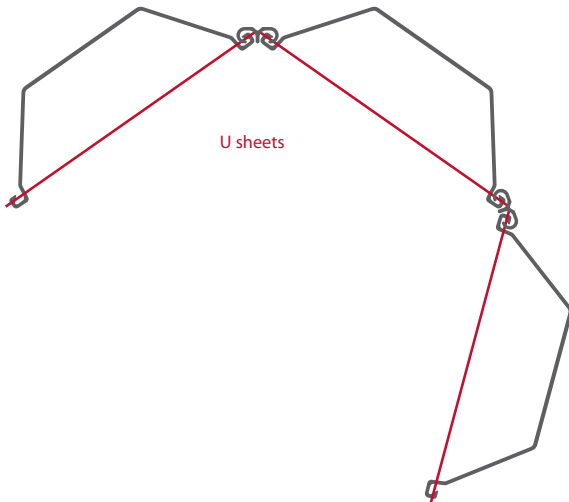
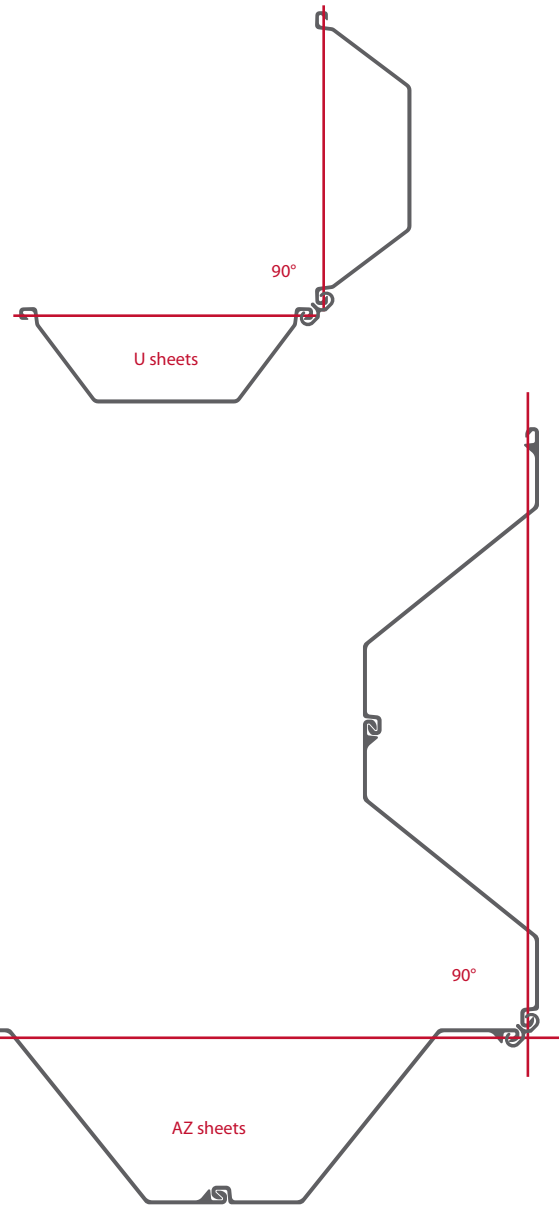
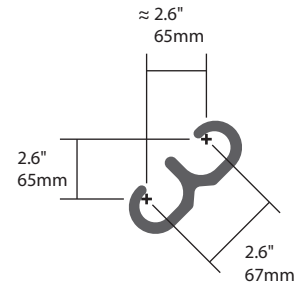

WEIGHT:
~ 8.1 lb/ft
~ 12.1 kg/m

STEEL GRADE:
ASTM A572 Gr. 50/60
ASTM A690 MARINER Steel



For additional details:
pilepro.com/omega

Flexibility

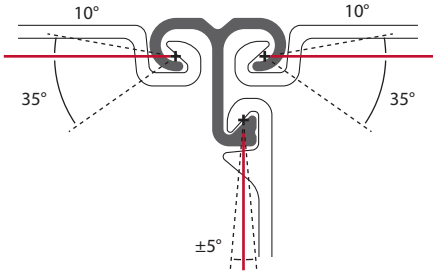

Dimensions

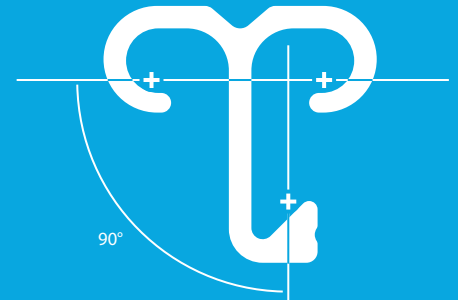
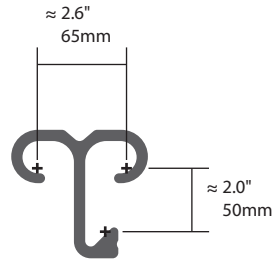

Omega Tee

For omega corners ($\pm 70^\circ$ to $\pm 190^\circ$),
T-corners, and 90° corners

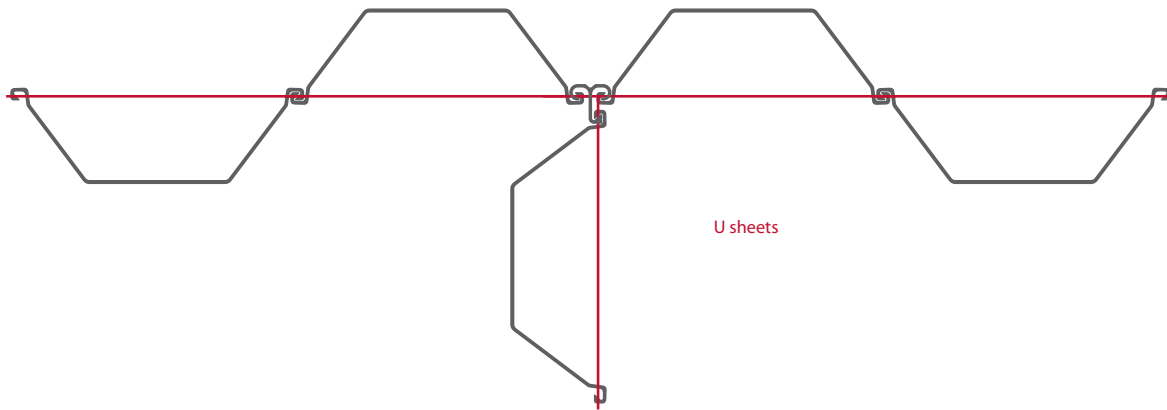

U sheets

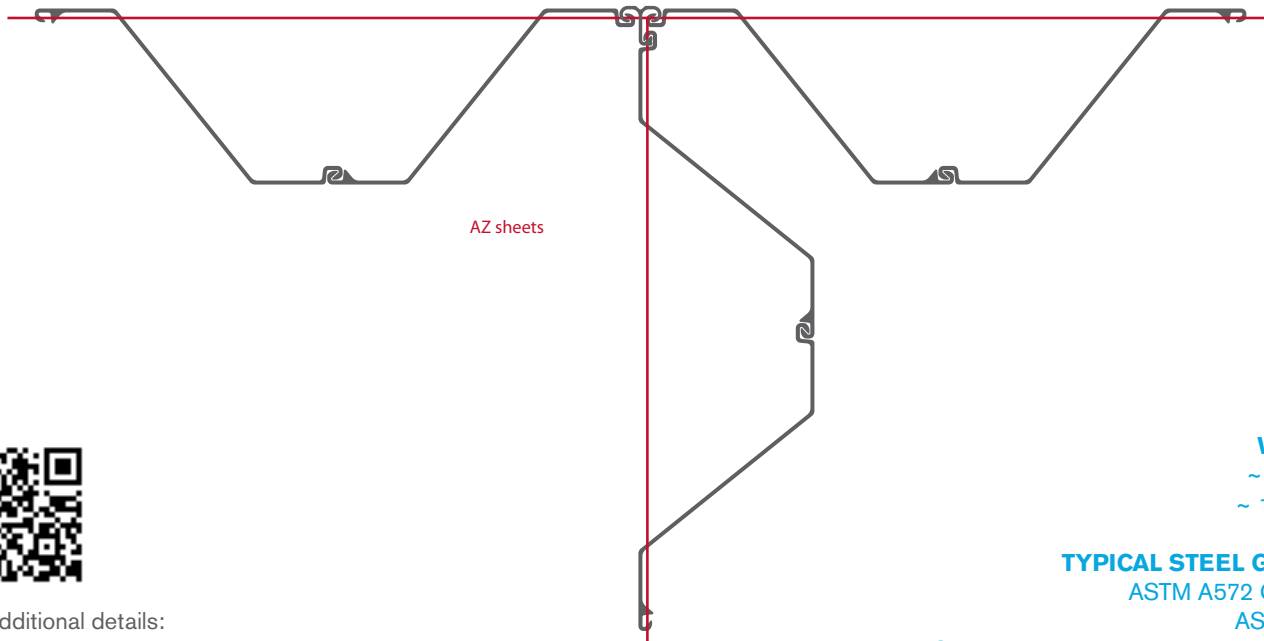

AZ sheets



For additional details:
pilepro.com/omegat

WEIGHT:
~ 12.1 lb/ft
~ 18.0 kg/m

TYPICAL STEEL GRADES:
ASTM A572 Gr. 50/60
ASTM A690

Other steel grades available upon request.

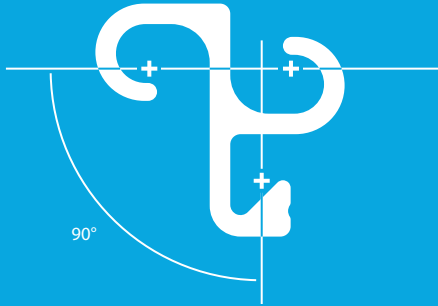

AZ Tee™

For T-corners and 90° corners

Flexibility

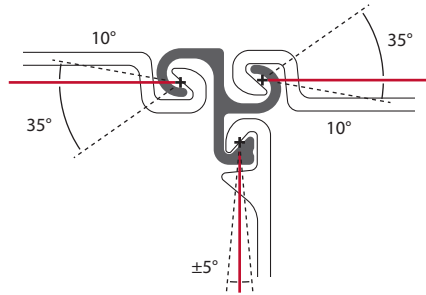

Dimensions

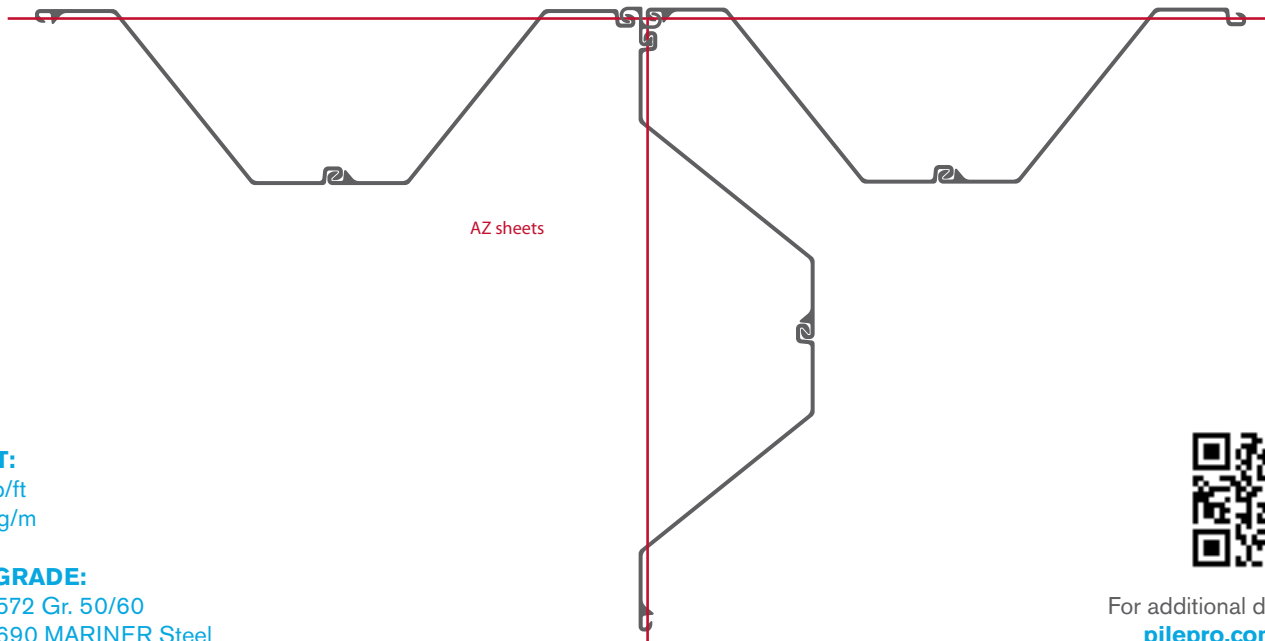
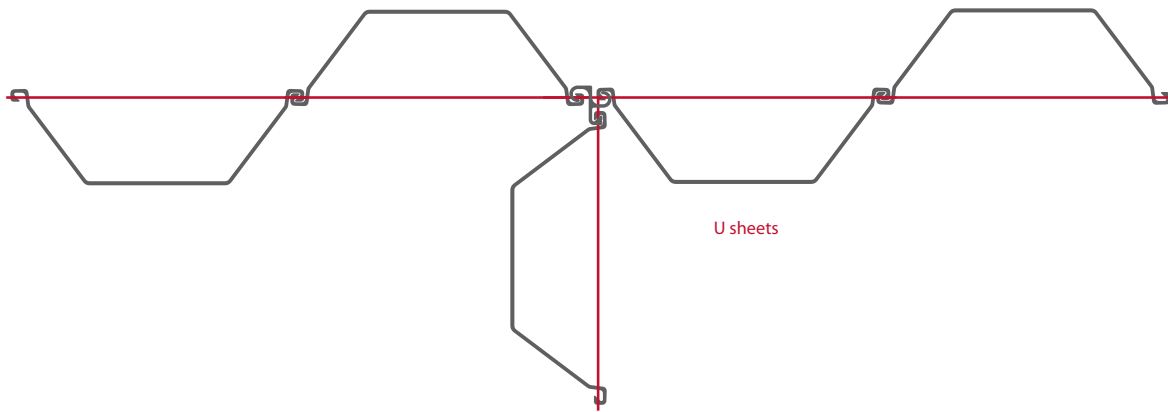
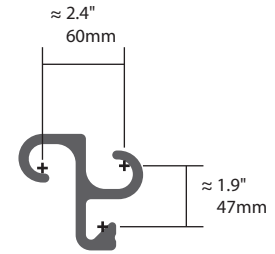

WEIGHT:
 ~ 12.4 lb/ft
 ~ 18.4 kg/m

STEEL GRADE:
 ASTM A572 Gr. 50/60
 ASTM A690 MARINER Steel



For additional details:
pilepro.com/azt

Flexibility

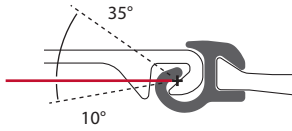

Dimensions



PL

**For combined sheet pile walls
(Peiner beams)**

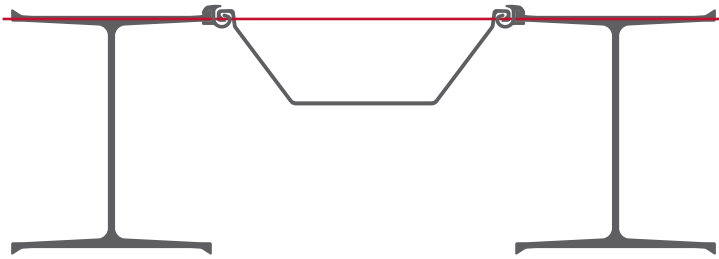

U sheets + Peiner beams

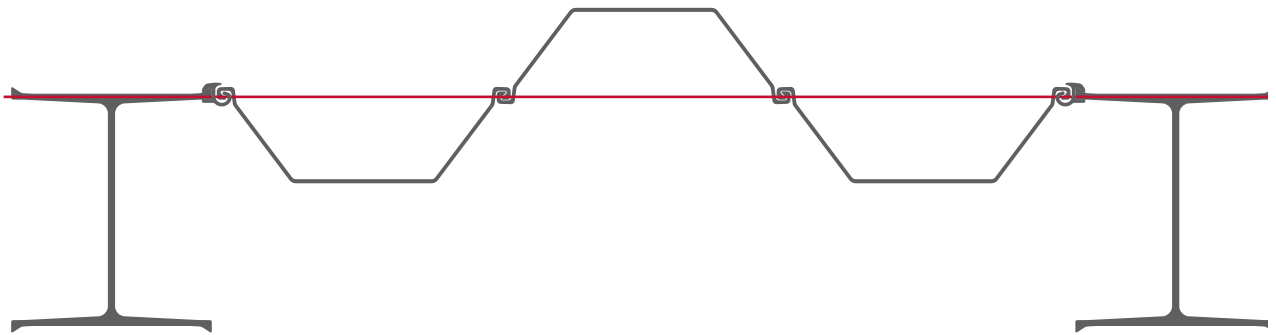

For additional details:
pilepro.com/pl

WEIGHT:
~ 11.7 lb/ft
~ 17.4 kg/m

TYPICAL STEEL GRADES:
ASTM A572 Gr. 50/60
ASTM A690

Other steel grades available upon request.





B-Tank I

For ultra-sturdy combined
sheet pile walls
(Wide-flange beams)

Flexibility

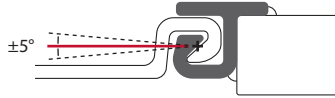

Dimensions

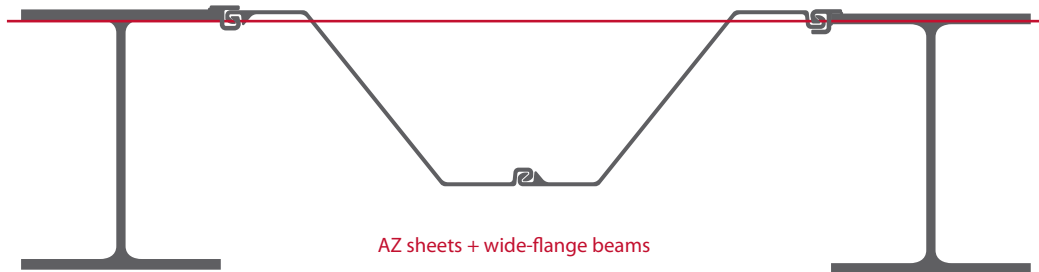

WEIGHT:
~ 13.2 lb/ft
~ 19.6 kg/m

STEEL GRADE:
ASTM A572 Gr. 50/60
ASTM A690 MARINER Steel



For additional details:
pilepro.com/btank1

Flexibility

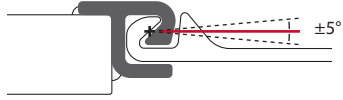

Dimensions

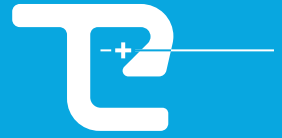
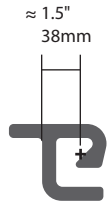

B-Tank II

For ultra-sturdy combined
sheet pile walls
(wide-flange beams)

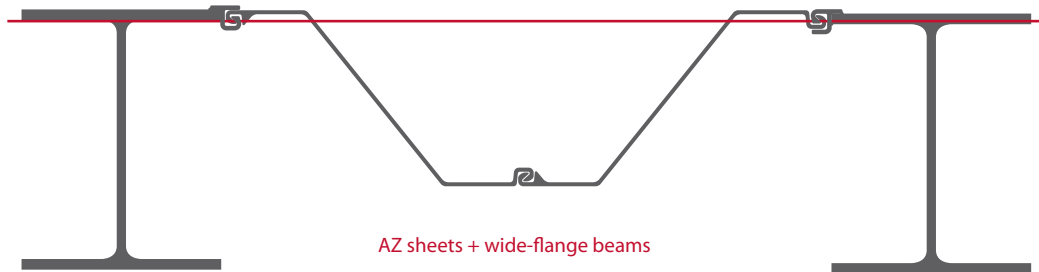

For additional details:
pilepro.com/btank2

WEIGHT:
~ 13.3 lb/ft
~ 19.8 kg/m

TYPICAL STEEL GRADES:
ASTM A572 Gr. 50/60
ASTM A690

Other steel grades available upon request.



Flexibility

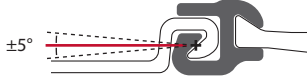

Dimensions



P-Tank I

For ultra-sturdy combined
sheet pile walls (Peiner beams)

AZ sheets + Peiner beams

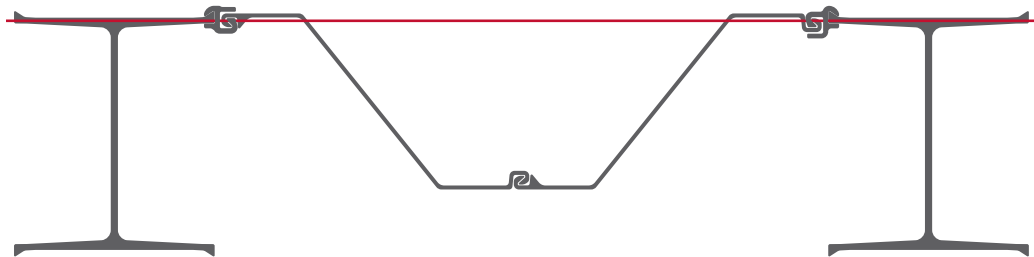

WEIGHT:
~ 15.5 lb/ft
~ 23.1 kg/m

STEEL GRADE:
ASTM A572 Gr. 50/60
ASTM A690 MARINER Steel



For additional details:
pilepro.com/ptank1

Flexibility

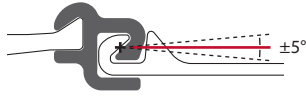

Dimensions

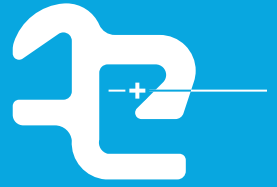

P-Tank II

For ultra-sturdy combined
sheet pile walls (Peiner beams)

AZ sheets + Peiner beams

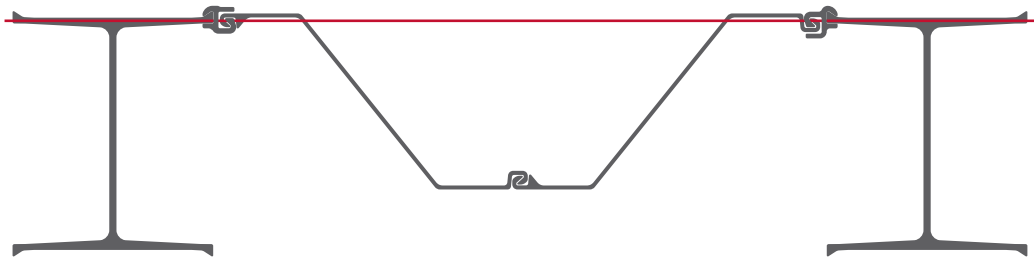

For additional details:
pilepro.com/ptank2

WEIGHT:
~ 16.2 lb/ft
~ 24.1 kg/m

TYPICAL STEEL GRADES:
ASTM A572 Gr. 50/60
ASTM A690

Other steel grades available upon request.





V 22

For combined sheet pile walls (pipes)

Flexibility

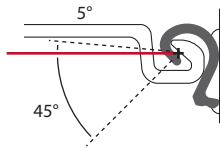

Dimensions

≈ 1.2"
31mm

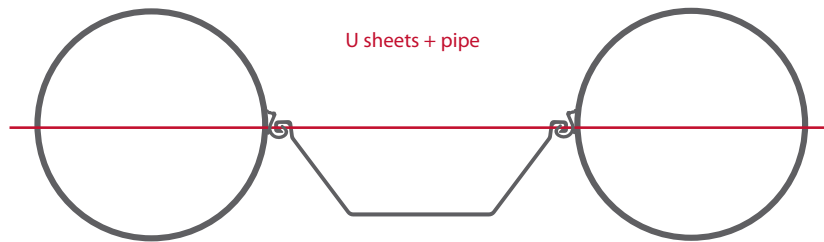

U sheets + pipe

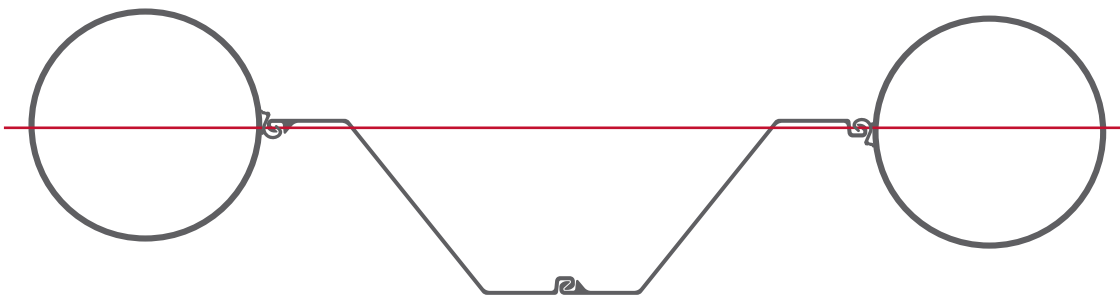

AZ sheets + pipe

WEIGHT:

~ 5.2 lb/ft
~ 7.7 kg/m

STEEL GRADE:

ASTM A572 Gr. 50/60
ASTM A690 MARINER Steel



For additional details:
pilepro.com/v22

Flexibility

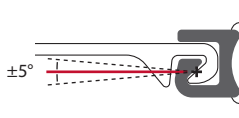

Dimensions

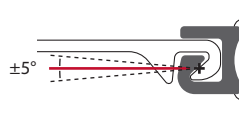

Tank

For ultra-sturdy combined
sheet pile walls (pipes)

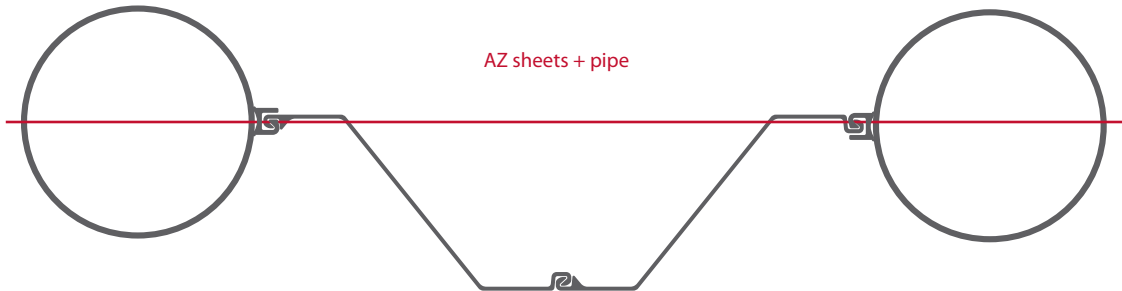

For additional details:
pilepro.com/tank

WEIGHT:
~ 13.0 lb/ft
~ 19.4 kg/m

TYPICAL STEEL GRADES:
ASTM A572 Gr. 50/60
ASTM A690

Other steel grades available upon request.



Installation Guide

Any-Z, V 20, AZ 90, Omega, Omega Tee, VTS

1. Please review the proper interlocking examples that are listed.
2. Thread the connector into the interlock while the sheet pile is out of the ground.
3. Adjust the connector to the appropriate position.
4. Tack or spot-weld the connector in place. Typically, a ~250mm (~10") weld attaching the connector to the sheet pile to the top is sufficient.
5. Drive/extract the sheet pile (with the connector attached) as you would normally.

B-Tank

1. The beams are delivered with the connectors already attached.
2. First, install the king piles (beams) as you would in any combined sheet pile wall application.
3. Grasp the sheet piling and thread between the already installed beams.
4. All welding seams are a minimum ~6mm (~0.25").
5. Both sides have a continuous minimum tip and toe welding of ~500mm (~20").
6. Both sides are tack welded in the free length between tip and toe welding with ~200mm/m (~8"/yd). The distance from seam to seam is ~800mm (~31.5") or less.
7. In salt water, the water side is continuously welded on the whole pile length. Follow the instructions above for the reverse side of the pile, if it is not in contact with salt water.

P-Tank, PL

1. Install the Peiner beams first.
2. Lay the sheet piling horizontally and thread the connector into the interlock of the sheet piling, adjusting the connector to the appropriate position (please review the proper interlocking examples). This can be done at the mill, at a distributor's yard, or on the job site (go here: www.pilepro.com/thread).
3. Tack or spot-weld the connector in place. Typically, a ~250mm (~10") weld attaching the connector to the sheet pile to the top is sufficient.
4. Grasp the sheet pile (with connectors already attached) and thread between the already installed Peiner type beams.
5. Lower/drive the sheet piling to the level of the Peiner type beam.

V 22, Tank

1. The pipes are delivered with the connectors already attached.
2. First, install the king piles (pipes) as you would in any combined sheet pile wall application.
3. Grasp the sheet piling and thread between the already installed pipe piles.
4. Increase flexibility in the middle interlocks of the sheet piles, combined with the swing of the connectors, to enable easier threading of the intermediate sheet piling.
5. All welding seams are a minimum ~6mm (~0.25").
6. Both sides have a continuous minimum tip and toe welding of ~500mm (~20").
7. Both sides are tack welded in the free length between tip and toe welding with 200mm/m (8"/yd). The distance from seam to seam is ~800mm (~31.5") or less.
8. In salt water, the water side is continuously welded on the whole pile length. Follow the instructions above for the reverse side of the pile, if it is not in contact with salt water.

Interlocking Guide

Proper Use

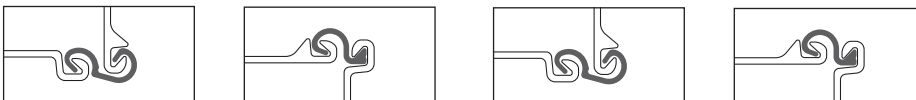

For Ball & Socket

PilePro is the exclusive manufacturer of domestic Ball & Socket connectors in North America. The range includes corners and junction piles along with numerous options for pipe-Z combined walls and Beam combined walls. It also includes the multi-use Any-Z connector which can be used to transition from Larsen Z to Ball & Socket.

Angle rotation and interlock flexibility figures shown on following pages may vary subject to product rolling tolerances.

Any-Z	28	Bullhead™	35
PZ 90™	29	BBS-M/BBS-F	36
Colt	30	PBS-M/PBS-F	38
Cobra	31	WOM/WOF™	40
PZ Tee™	32	WOM-XL/WOF-XL™	42
PZT-S	33	WOM-XXL/WOF-XXL™	44
Joker™	34		



System Overview

For PZ/PZC Sheet Pile

Don't see the
best solution?
Call us at
(866) 666-7453

PZ 90, p. 29

For 90° corners ($\pm 40^\circ$)

Joker, p. 34

For T-corners,
For 90° Corners ($\pm 40^\circ$)

PZT-S, p. 33

For T-corners,
For 90° Corners ($\pm 40^\circ$)

Any-Z, p. 28

For 90° corners ($\pm 40^\circ$)

PZ Tee, p. 32

For T-corners,
For 90° Corners ($\pm 40^\circ$)

Cobra, p. 31

For 135° corners ($\pm 40^\circ$)

Colt, p. 30

For 45° corners ($\pm 40^\circ$)

Bullhead, p. 35

For T-corners,
For 90° Corners ($\pm 40^\circ$)

We have the right connector for all of your Ball & Socket sheet pile projects.

Having trouble finding the best solution? Call us at (866) 666-7453 or email sales@pilepro.com and we will find the solution with you.

For Combined Sheet Piles

BBS-M/BBS-F, p. 36

For combined sheet pile walls (wide flange beams)

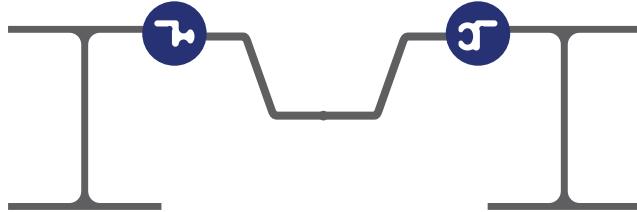

PBS-M/PBS-F, p. 38

For combined sheet pile walls (Peiner beams)

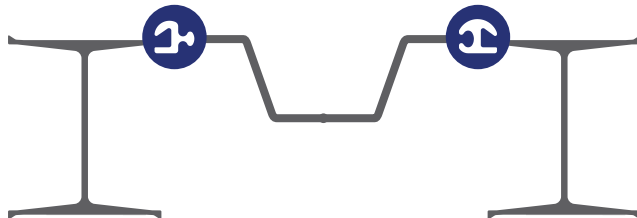

WOM/WOF, p. 40

For combined sheet pile walls (pipes)



WOM-XL/ WOF-XL, p. 42

For combined sheet pile walls (pipes), for Pipe Sheet Pile walls



WOM-XXL/ WOF-XXL, p. 44

For combined sheet pile walls (pipes), for Pipe Sheet Pile walls



For Transition Piles

Any-Z, p. 28

For PZ/PZC ↔ AZ/Larssen transitions

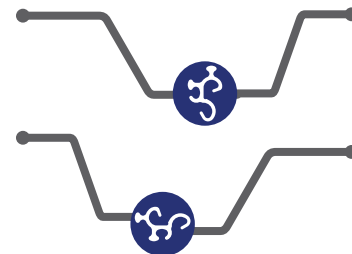

PZ/PZC ↔ CF/Cold formed transitions



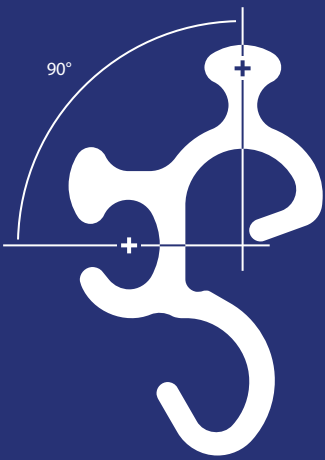

Any-Z

For 90° corners ($\pm 40^\circ$),
for PZ/PZC \leftrightarrow AZ/Larssen,
for PZ/PZC \leftrightarrow CF/Cold formed

Flexibility

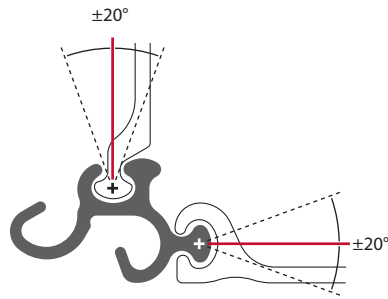

Dimensions

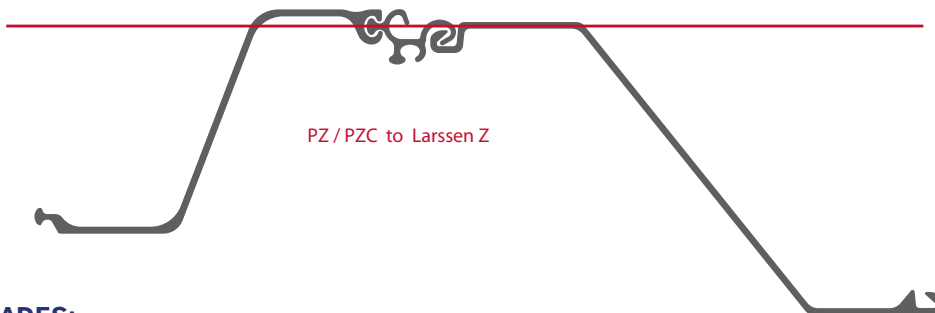
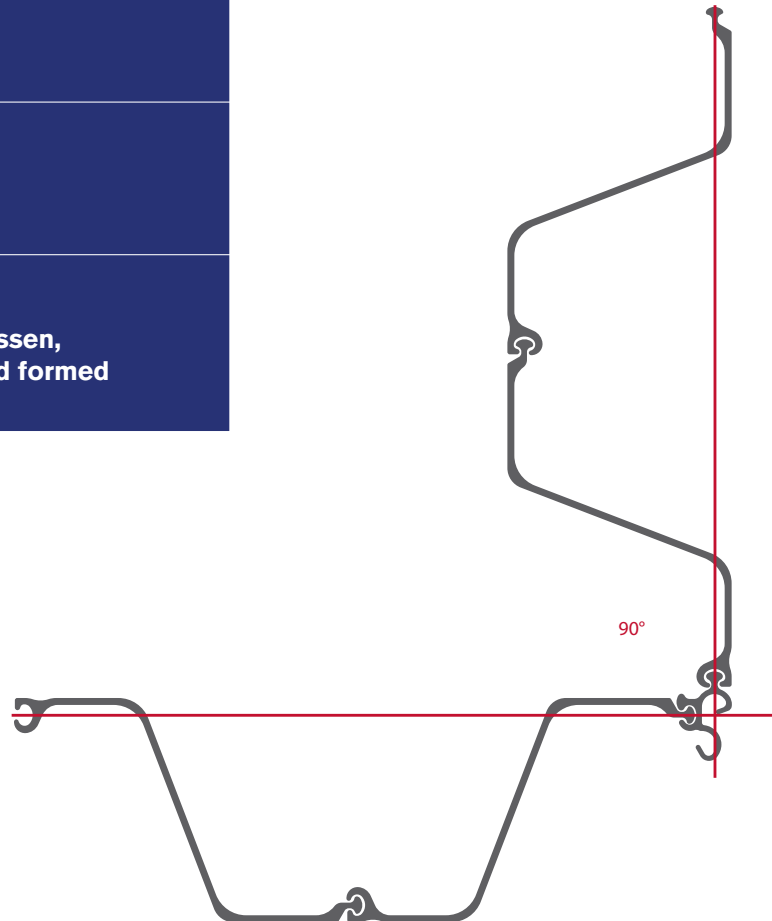
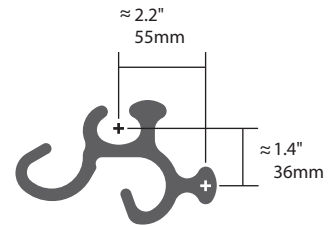

WEIGHT:
~ 14.6 lb/ft
~ 21.7 kg/m

TYPICAL STEEL GRADES:
ASTM A572 Gr. 50/60
ASTM A690
Other steel grades available upon request.



For additional details:
pilepro.com/anyz



Flexibility

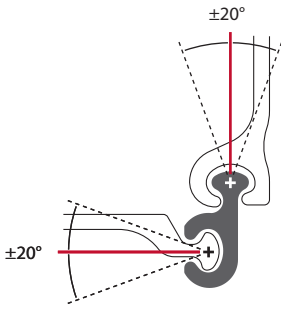

Dimensions

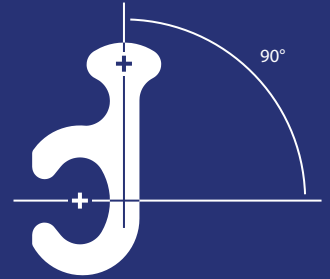
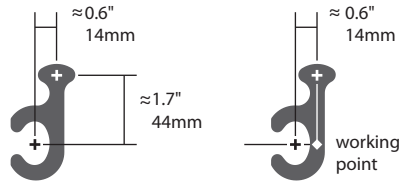

PZ 90

For 90° corners (± 40°)

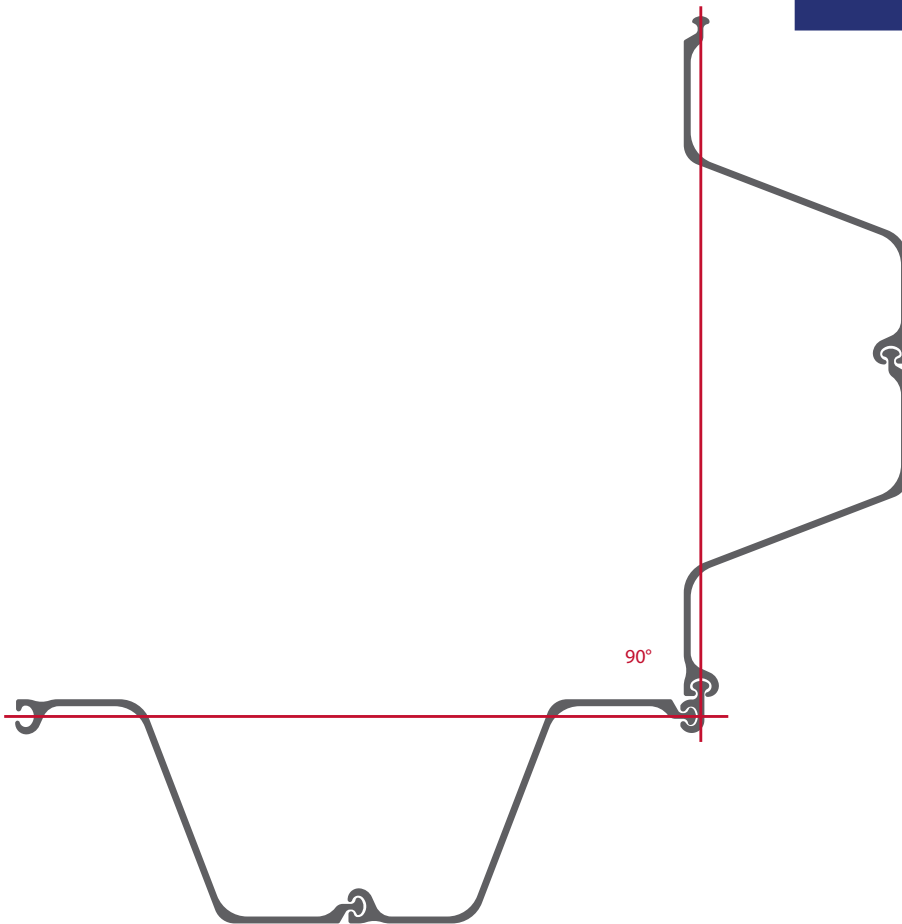

For additional details:
pilepro.com/pz90

WEIGHT:
~ 7.3 lb/ft
~ 10.9 kg/m

TYPICAL STEEL GRADES:
ASTM A572 Gr. 50/60
ASTM A690

Other steel grades available upon request.



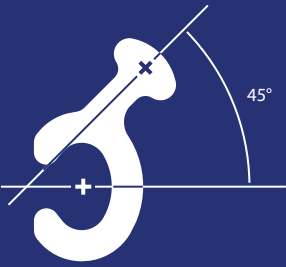

Colt

For 45° corners ($\pm 40^\circ$)

Flexibility

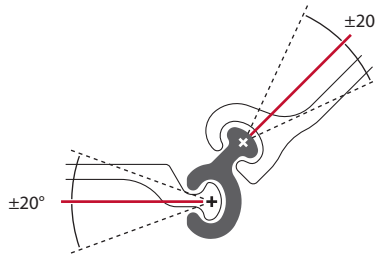

Dimensions

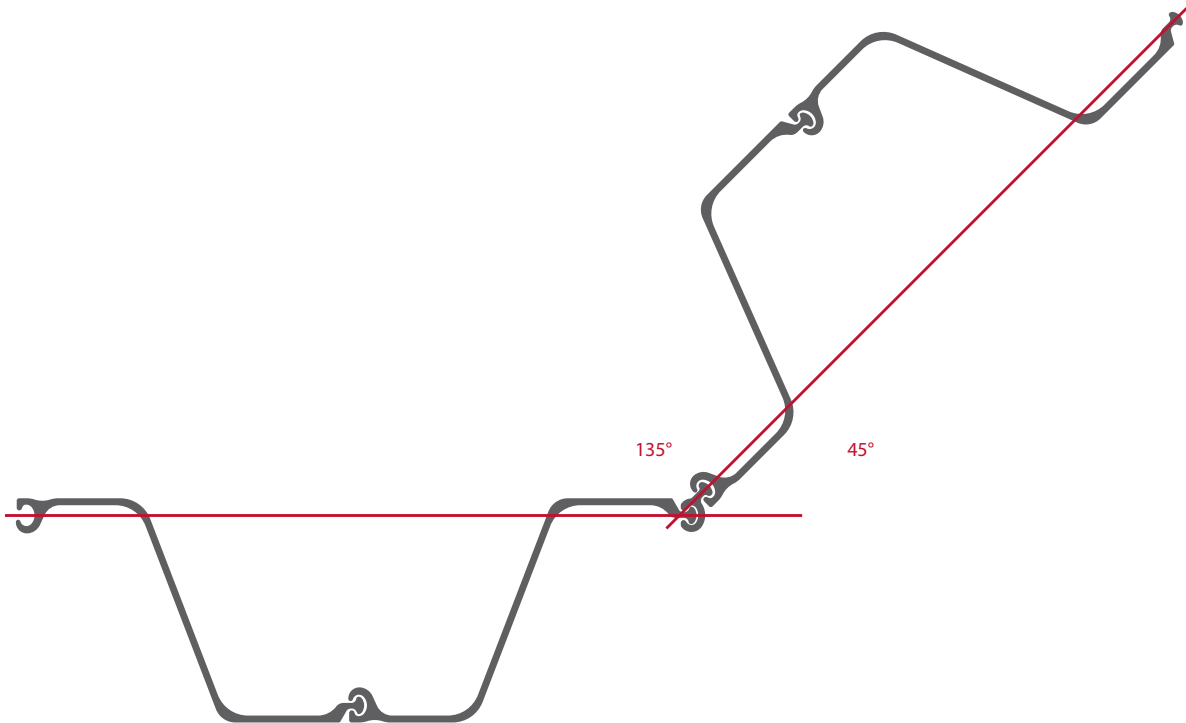
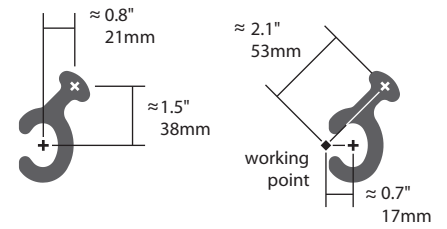

WEIGHT:

~ 6.9 lb/ft
~ 10.2 kg/m

TYPICAL STEEL GRADES:

ASTM A572 Gr. 50/60
ASTM A690
Other steel grades available upon request.



For additional details:
pilepro.com/colt

Flexibility

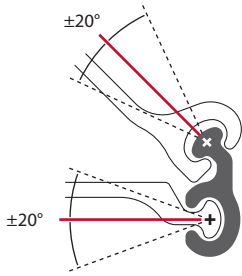

Dimensions

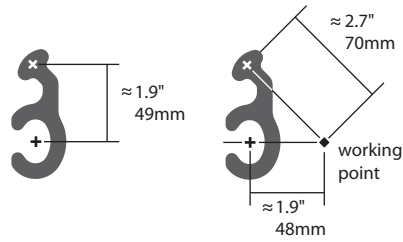

Cobra

For 135° corners (± 40°)

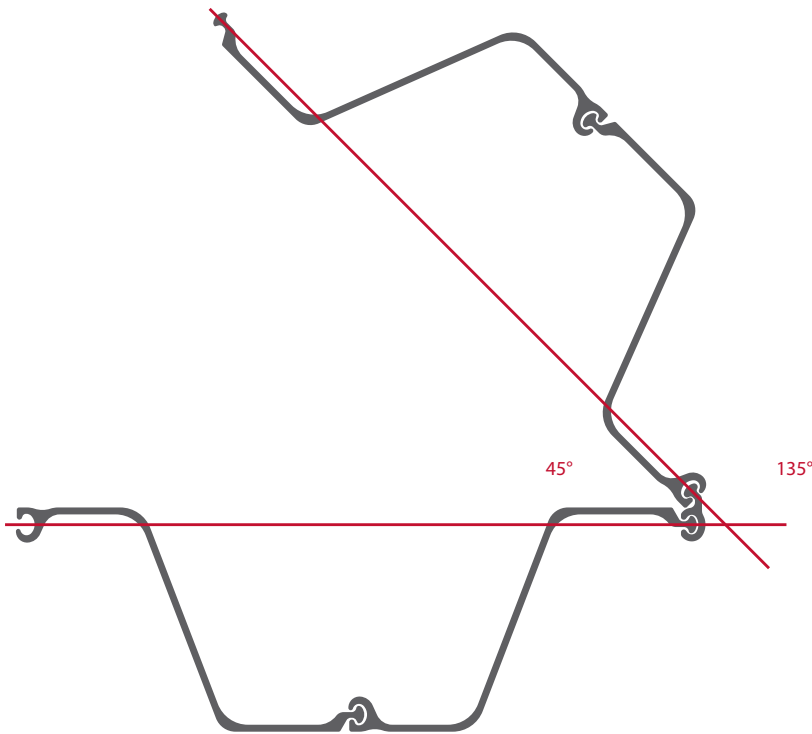

For additional details:
pilepro.com/cobra

WEIGHT:
~ 7.5 lb/ft
~ 11.1 kg/m

TYPICAL STEEL GRADES:
ASTM A572 Gr. 50/60
ASTM A690

Other steel grades available upon request.



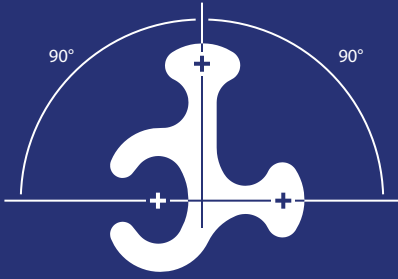

PZ Tee

For T-corners, For 90° corners (± 40°)

Flexibility

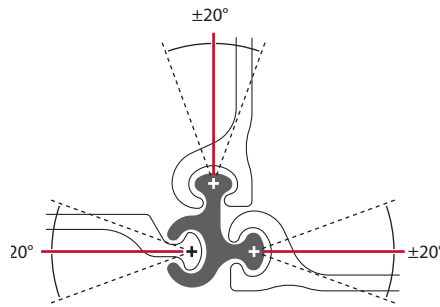

Dimensions

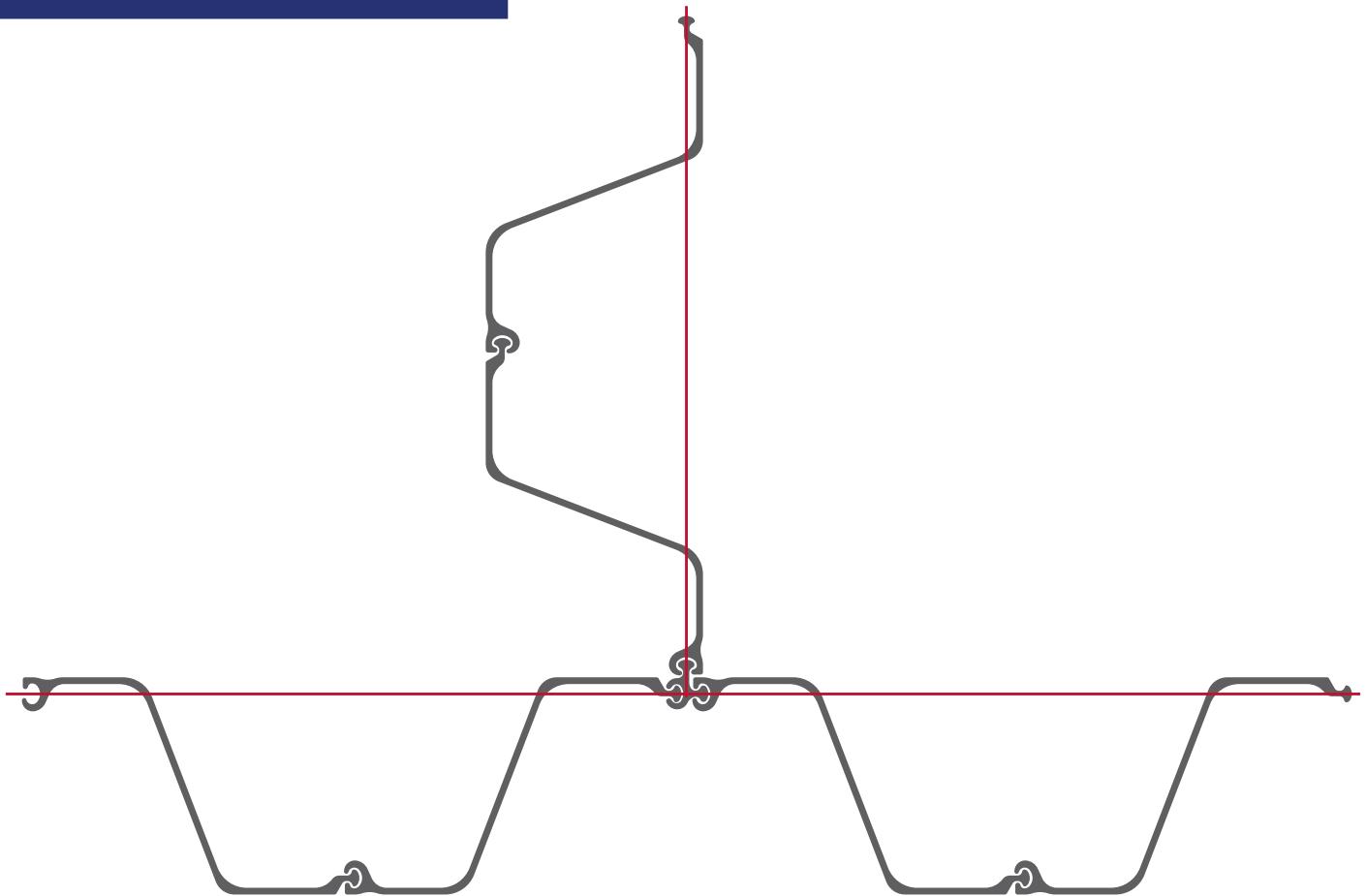
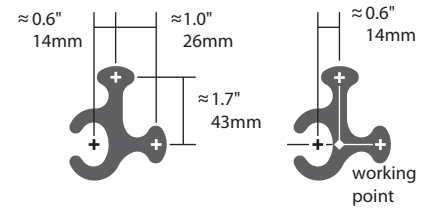

WEIGHT:

~ 9.0 lb/ft
~ 13.4 kg/m

TYPICAL STEEL GRADES:

ASTM A572 Gr. 50/60
ASTM A690
Other steel grades available upon request.



For additional details:
pilepro.com/pztee

Flexibility

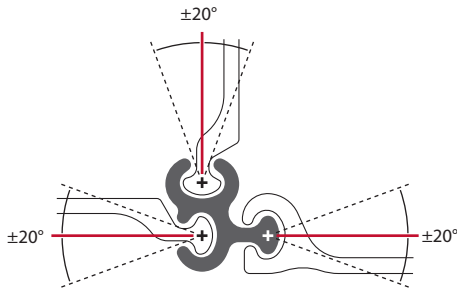

Dimensions

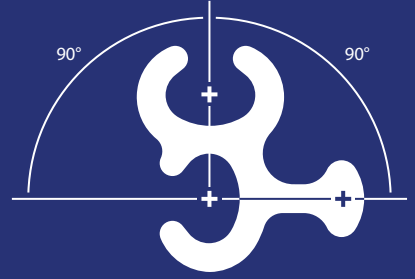
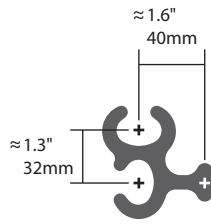

PZT-S

For T-corners, For 90° corners ($\pm 40^\circ$)

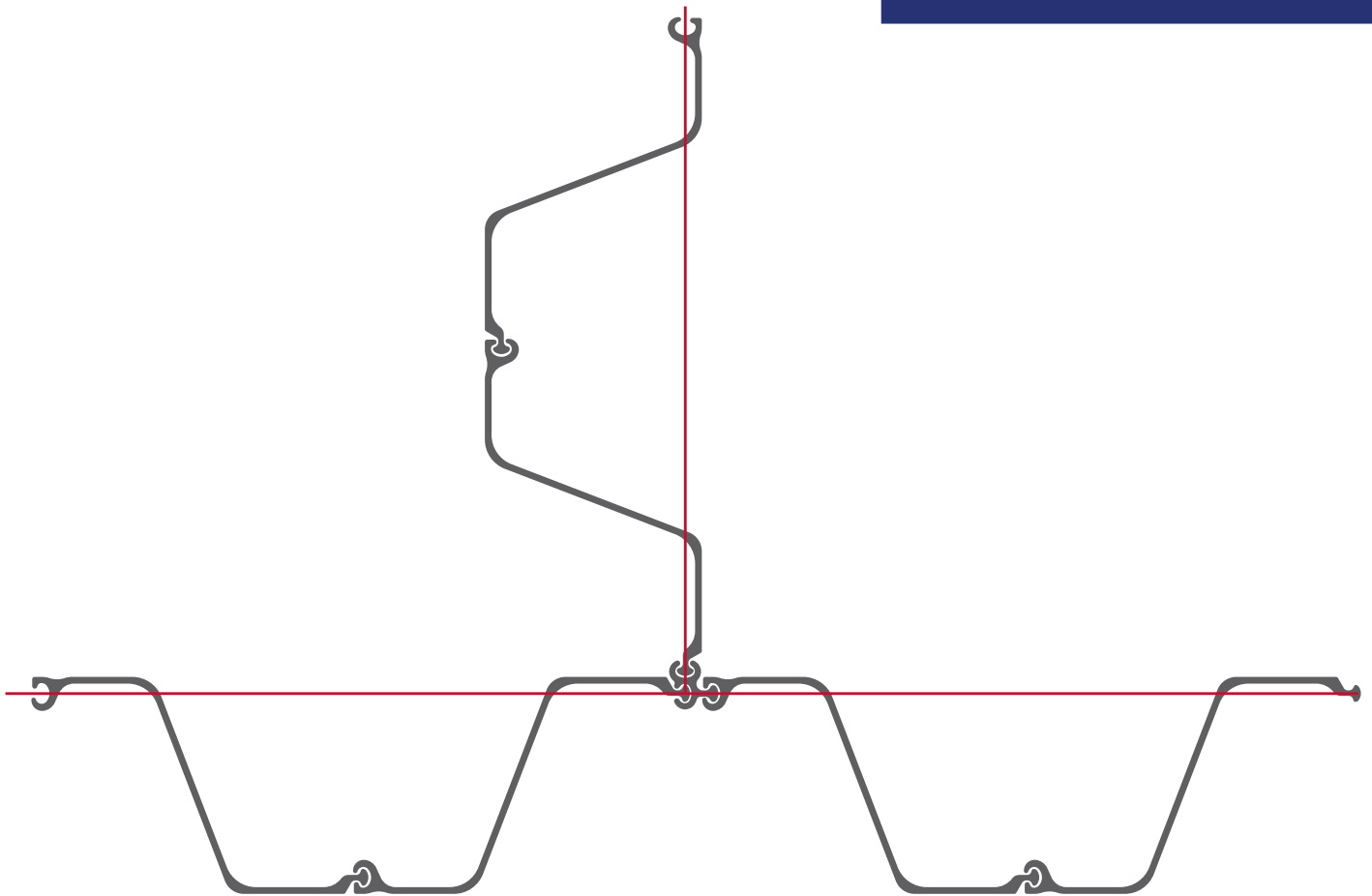

For additional details:
pilepro.com/ptzs

WEIGHT:
~ 9.7 lb/ft
~ 14.4 kg/m

TYPICAL STEEL GRADES:
ASTM A572 Gr. 50/60
ASTM A690

Other steel grades available upon request.



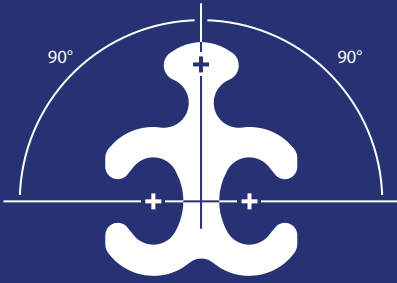

Joker®

For T-corners, For 90° corners ($\pm 40^\circ$)

Flexibility

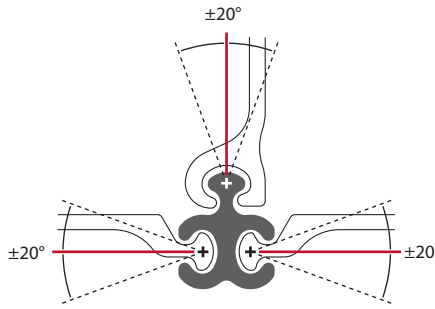

Dimensions

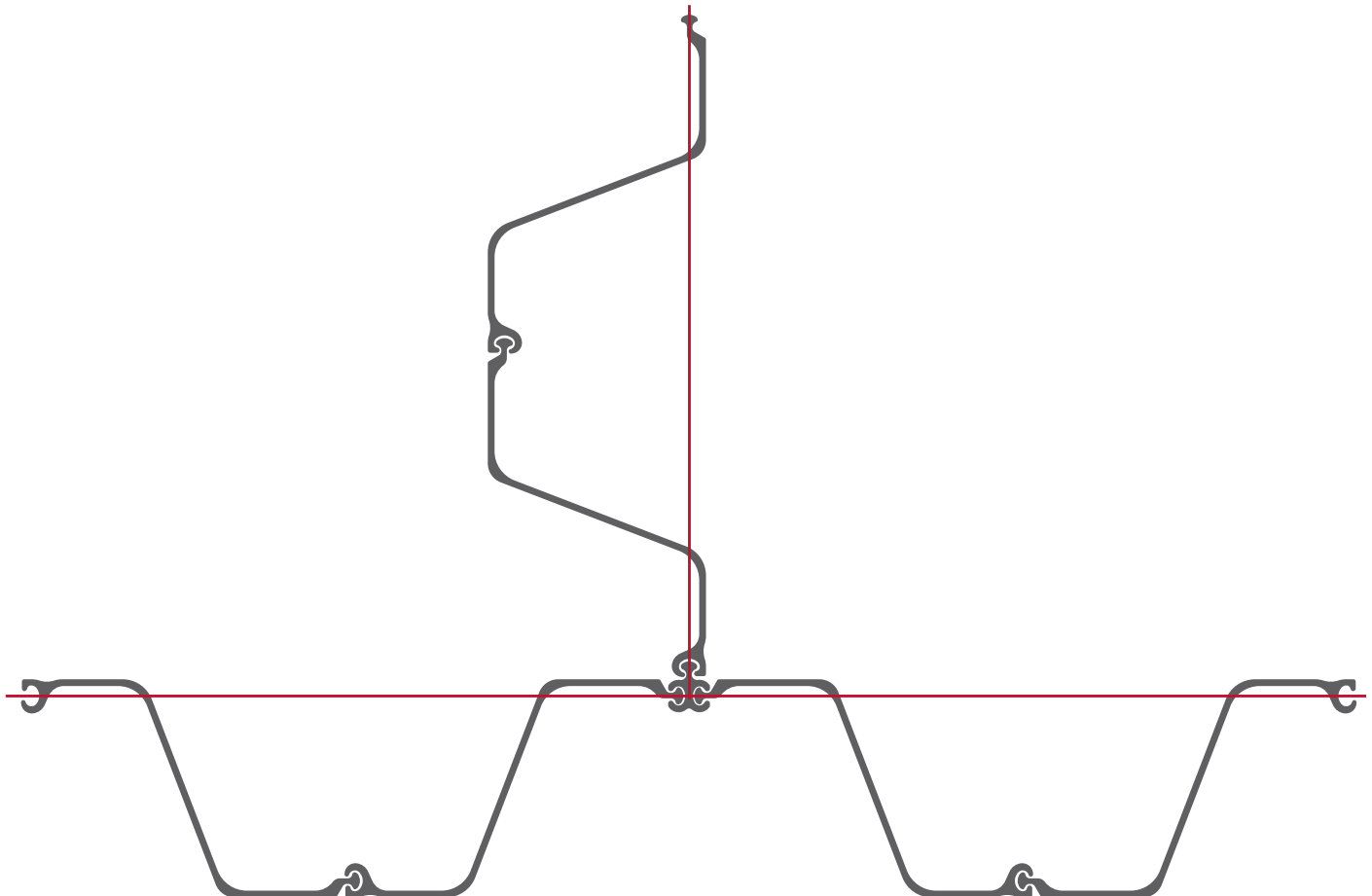
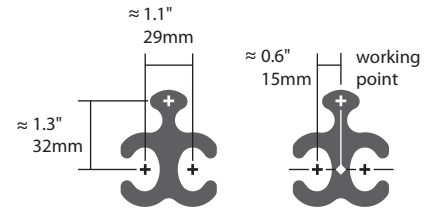

WEIGHT:
 ~ 10.9 lb/ft
 ~ 16.2 kg/m

TYPICAL STEEL GRADES:
 ASTM A572 Gr. 50/60
 ASTM A690
 Other steel grades available upon request.



For additional details:
pilepro.com/joker

Flexibility

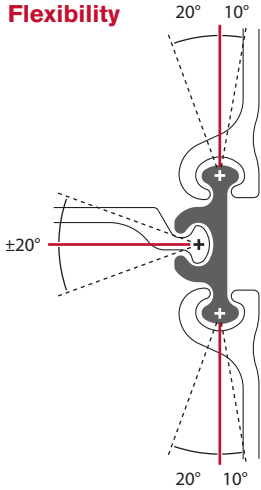

Dimensions

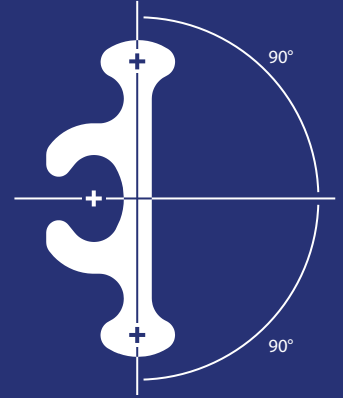
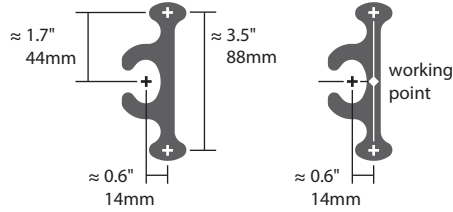

Bullhead®

For T-corners, For 90° corners (± 40°)

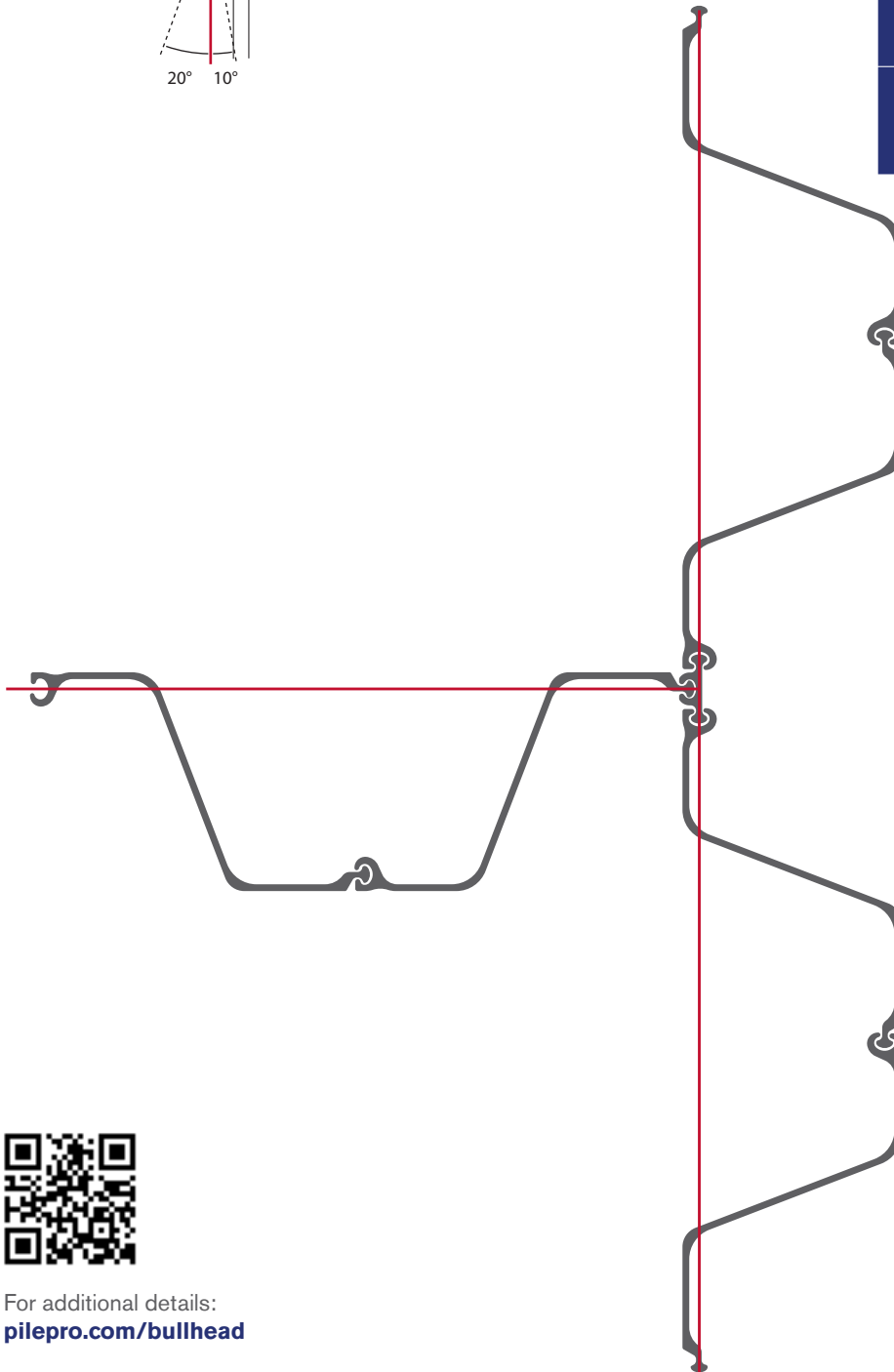

For additional details:
pilepro.com/bullhead

WEIGHT:
 ~ 9.7 lb/ft
 ~ 14.5 kg/m

TYPICAL STEEL GRADES:
 ASTM A572 Gr. 50/60
 ASTM A690

Other steel grades available upon request.



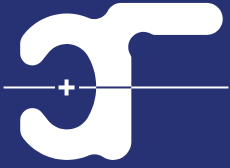

BBS-F

For combined walls
(wide flange beams)

Flexibility

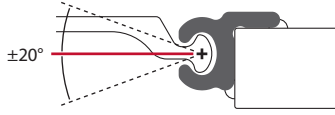

Dimensions

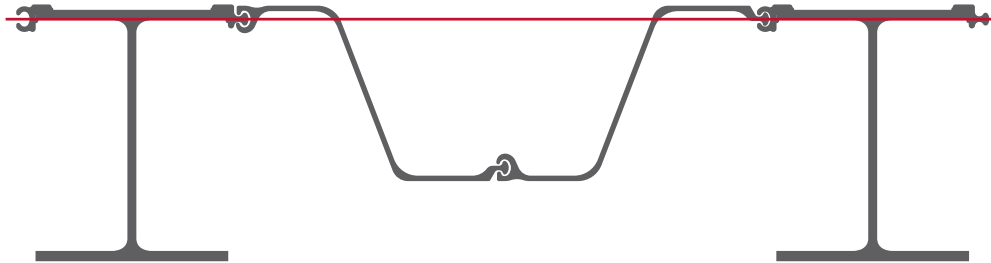
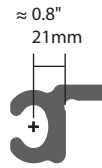

WEIGHT:

~ 7.5 lb/ft
~ 11.2 kg/m

TYPICAL STEEL GRADES:

ASTM A572 Gr. 50/60
ASTM A690
Other steel grades available upon request.



For additional details:
pilepro.com/bbsf

Flexibility

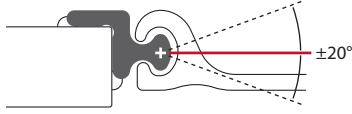

Dimensions

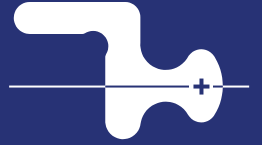
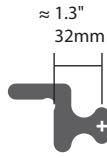

BBS-M

For combined walls
(wide flange beams)

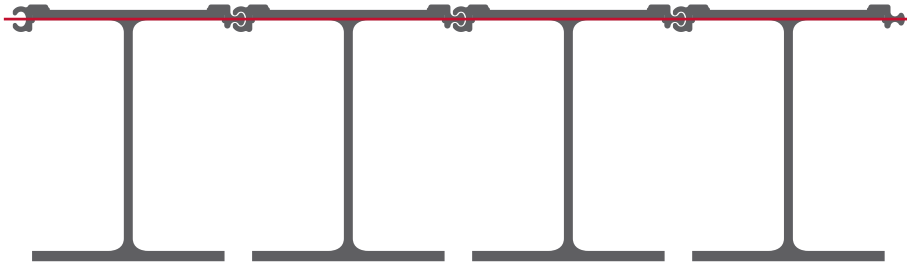

For additional details:
pilepro.com/bbsm

WEIGHT:
~ 6.5 lb/ft
~ 9.6 kg/m

TYPICAL STEEL GRADES:
ASTM A572 Gr. 50/60
ASTM A690

Other steel grades available upon request.



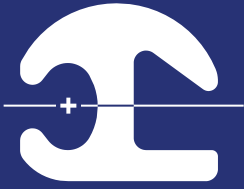

PBS-F

For combined walls (Peiner beams)

Flexibility

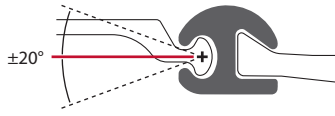

Dimensions

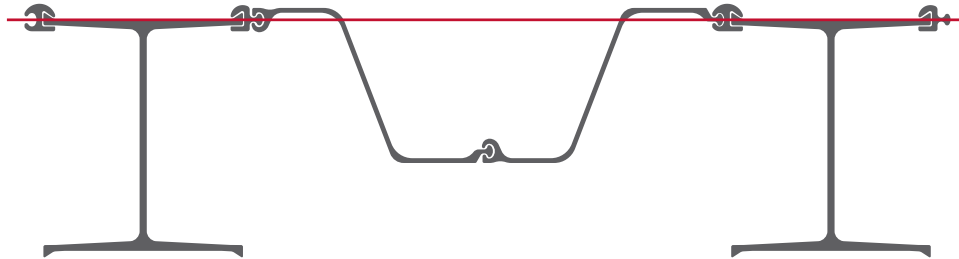

WEIGHT:
~ 10.7 lb/ft
~ 15.9 kg/m

TYPICAL STEEL GRADES:
ASTM A572 Gr. 50/60
ASTM A690
Other steel grades available upon request.



For additional details:
pilepro.com/pbsf

Flexibility

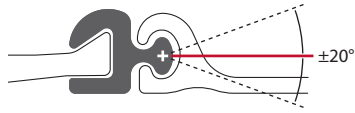

Dimensions

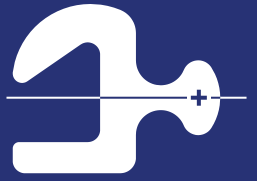
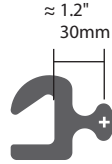

PBS-M

For combined walls (Peiner beams)

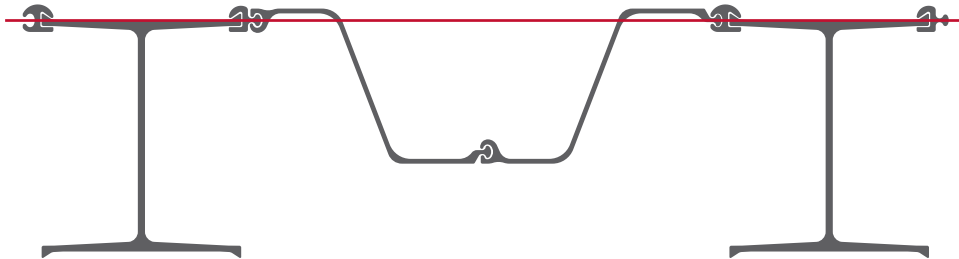

For additional details:
pilepro.com/pbsm

WEIGHT:
~ 9.0 lb/ft
~ 13.4 kg/m

TYPICAL STEEL GRADES:
ASTM A572 Gr. 50/60
ASTM A690

Other steel grades available upon request.





WOF

For combined sheet pile walls (pipes)

Flexibility

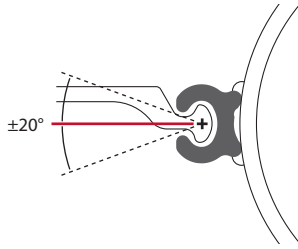

Dimensions

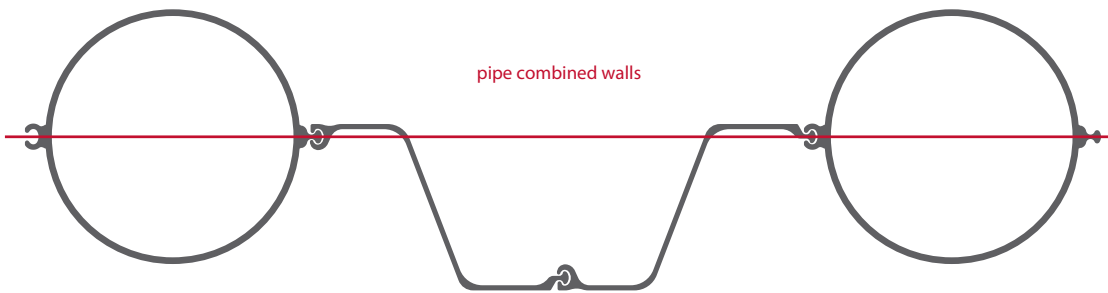
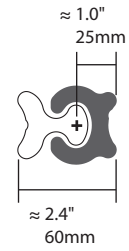

WEIGHT:

~ 5.6 lb/ft
~ 8.3 kg/m

TYPICAL STEEL GRADES:

ASTM A572 Gr. 50/60
ASTM A690
Other steel grades available upon request.



For additional details:
pilepro.com/wof

Flexibility

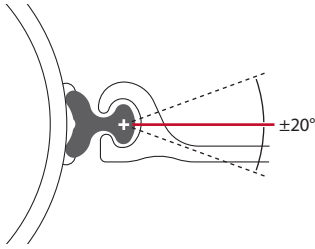

Dimensions

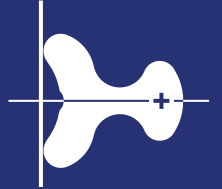

WOM

For combined sheet pile walls (pipes)

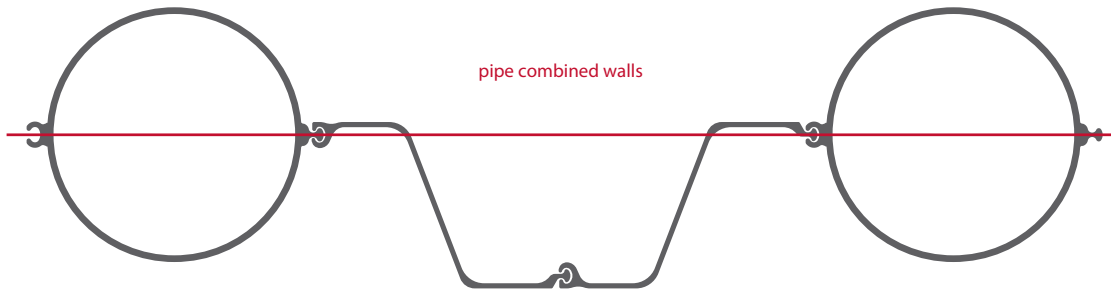

For additional details:
pilepro.com/wom

WEIGHT:
~ 4.6 lb/ft
~ 6.9 kg/m

TYPICAL STEEL GRADES:
ASTM A572 Gr. 50/60
ASTM A690

Other steel grades available upon request.



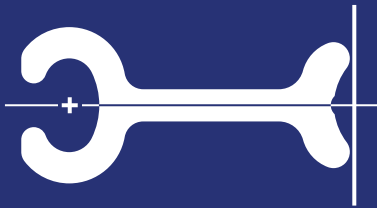

WOF-XL

For combined sheet pile walls (pipes),
For Pipe Sheet Pile walls

Flexibility

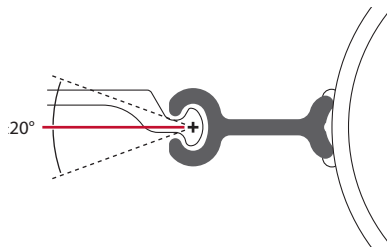

Dimensions

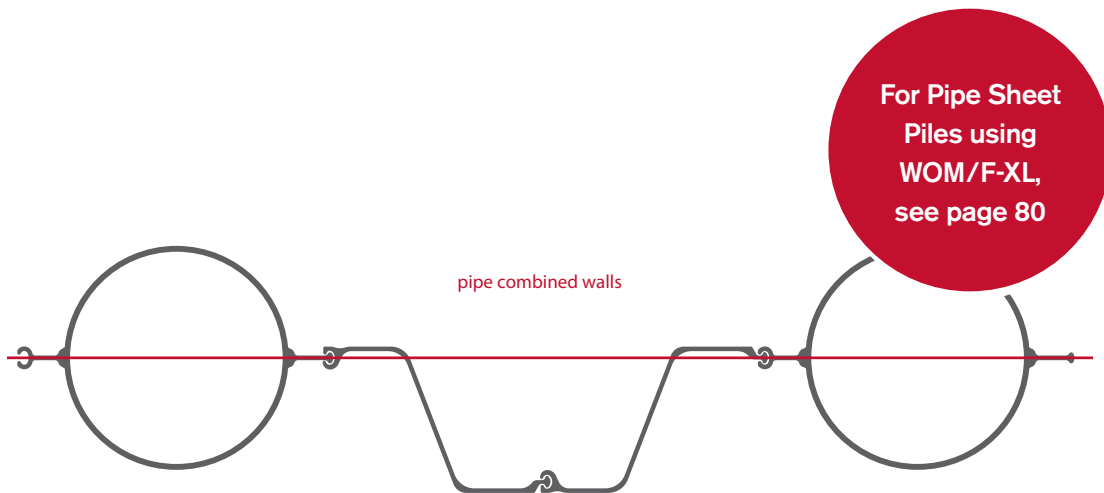
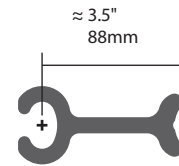

WEIGHT:
~ 12.0 lb/ft
~ 17.8 kg/m

TYPICAL STEEL GRADES:
ASTM A572 Gr. 50/60
ASTM A690
Other steel grades available upon request.



For additional details:
pilepro.com/wof-xl



Flexibility

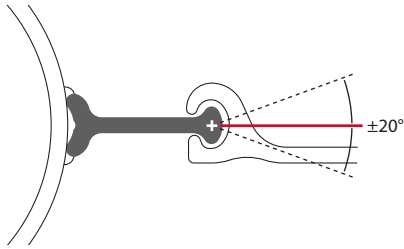

Dimensions

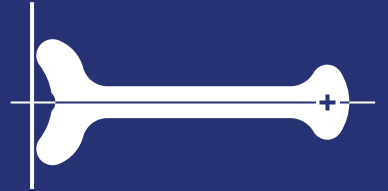
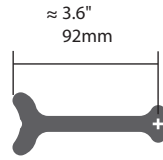

WOM-XL

For combined sheet pile walls (pipes),
For Pipe Sheet Pile walls

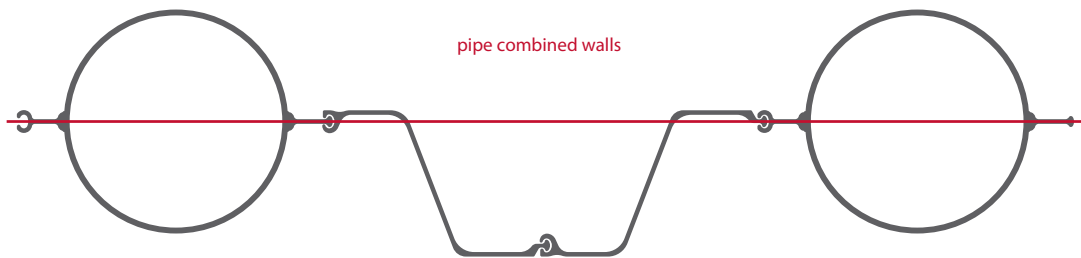

For additional details:
pilepro.com/wom-xl

WEIGHT:
~ 8.5 lb/ft
~ 12.7 kg/m

TYPICAL STEEL GRADES:
ASTM A572 Gr. 50/60
ASTM A690

Other steel grades available upon request.



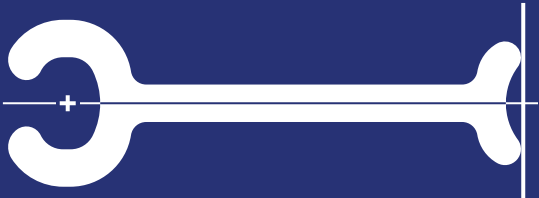

WOF-XXL

For combined sheet pile walls (pipes),
For Pipe Sheet Pile walls

Flexibility

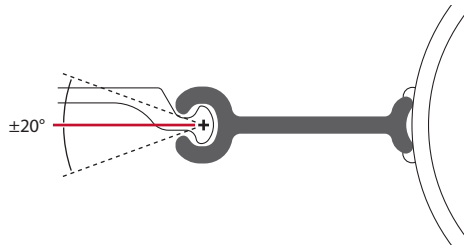

Dimensions

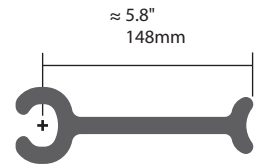

For Pipe Sheet
Piles using
WOM/F-XL,
see page 82

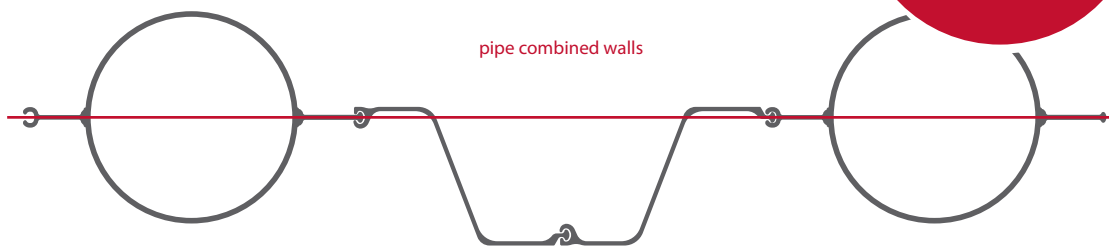

WEIGHT:

~ 15.8 lb/ft
~ 23.5 kg/m

TYPICAL STEEL GRADES:

ASTM A572 Gr. 50/60
ASTM A690
Other steel grades available upon request.



For additional details:
pilepro.com/wof-xxl

Flexibility

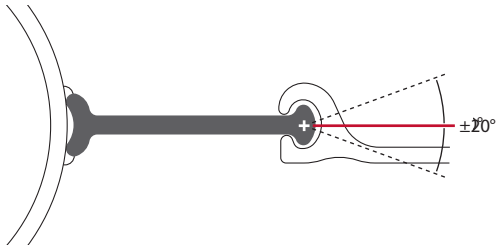

Dimensions

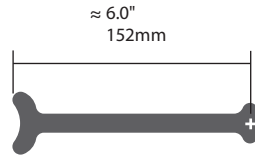

WOM-XXL

For combined sheet pile walls (pipes),
For Pipe Sheet Pile walls

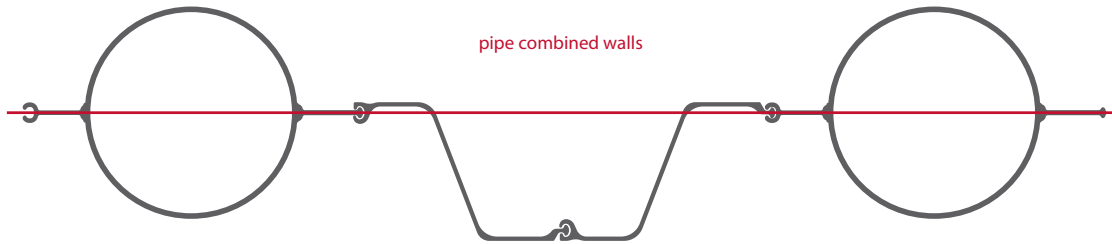

For additional details:
pilepro.com/wom-xxl

WEIGHT:
~ 12.4 lb/ft
~ 18.5 kg/m

TYPICAL STEEL GRADES:
ASTM A572 Gr. 50/60
ASTM A690

Other steel grades available upon request.



Installation Guide

Any-Z, Colt, PZ 90, Cobra, PZ Tee, PZT-S, Joker®, Bullhead™

1. Please review the proper interlocking examples that are listed.
2. Thread the connector into the interlock while the sheet pile is out of the ground.
3. Adjust the connector to the appropriate position.
4. Tack or spot-weld the connector in place. Typically, a ~250mm (~10") weld attaching the connector to the sheet pile to the top is sufficient.
5. Drive/extract the sheet pile (with the connector attached) as you would normally.

BBS-M/BBS-F

1. The beams are delivered with the connectors already attached.
2. First, install the king piles (beams) as you would in any combined sheet pile wall application.
3. Grasp the sheet piling and thread between the already installed beams.
4. All welding seams are a minimum ~6mm (~0.25").
5. Both sides have a continuous minimum tip and toe welding of ~500mm (~20").
6. Both sides are tack welded in the free length between tip and toe welding with ~200mm/m (~8"/yd). The distance from seam to seam is ~800mm (~31.5") or less.
7. In salt water, the water side is continuously welded on the whole pile length. Follow the instructions above for the reverse side of the pile, if it is not in contact with salt water.

PBS-M/PBS-F

1. Install the Peiner beams first.
2. Lay the sheet piling horizontally and thread the connector into the interlock of the sheet piling, adjusting the connector to the appropriate position (please review the proper interlocking examples). This can be done at the mill, at a distributor's yard, or on the job site (go here: www.pilepro.com/thread).
3. Tack or spot-weld the connector in place. Typically, a ~250mm (~10") weld attaching the connector to the sheet pile to the top is sufficient.
4. Grasp the sheet pile (with connectors already attached) and thread between the already installed Peiner type beams.
5. Lower/drive the sheet piling to the level of the Peiner type beam.

WOM/WOF, WOM-XL/WOF-XL, WOM-XXL/WOF-XXL

1. The pipes are delivered with the connectors already attached.
2. First, install the king piles (pipes) as you would in any combined sheet pile wall application.
3. Grasp the sheet piling and thread between the already installed pipe piles.
4. Increase flexibility in the middle interlocks of the sheet piles, combined with the swing of the connectors, to enable easier threading of the intermediate sheet piling.
5. All welding seams are a minimum ~6mm (~0.25").
6. Both sides have a continuous minimum tip and toe welding of ~500mm (~20").
7. Both sides are tack welded in the free length between tip and toe welding with 200mm/m (8"/yd). The distance from seam to seam is ~800mm (~31.5") or less.
8. In salt water, the water side is continuously welded on the whole pile length. Follow the instructions above for the reverse side of the pile, if it is not in contact with salt water.

Interlocking Guide

Proper Use

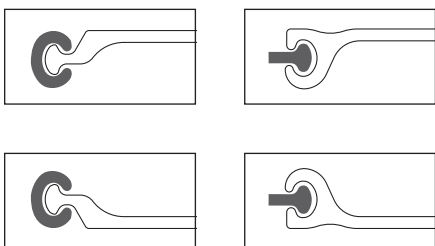

Improper Use

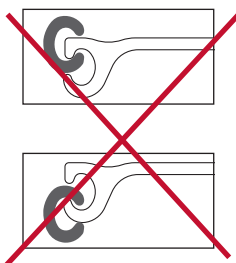

For Flat Sheet

The SWC flat sheet pile connectors enable cellular cofferdams to be constructed without the need for extensively welded fabricated junction piles.

The range of SWC connectors from 30° to 120° meets all requirements for cell formation.

ALSO, flat-sheet models in addition to the 120 Flat Sheet shown here are available in 30°, 60°, 90° by request.

Angle rotation and interlock flexibility figures shown on following pages may vary subject to product rolling tolerances.

120 Flat Sheet	51
SWC 30 A/B	52/53
SWC 60 A/B	54/55
SWC 90 A/B	56/57
SWC	58

System Overview

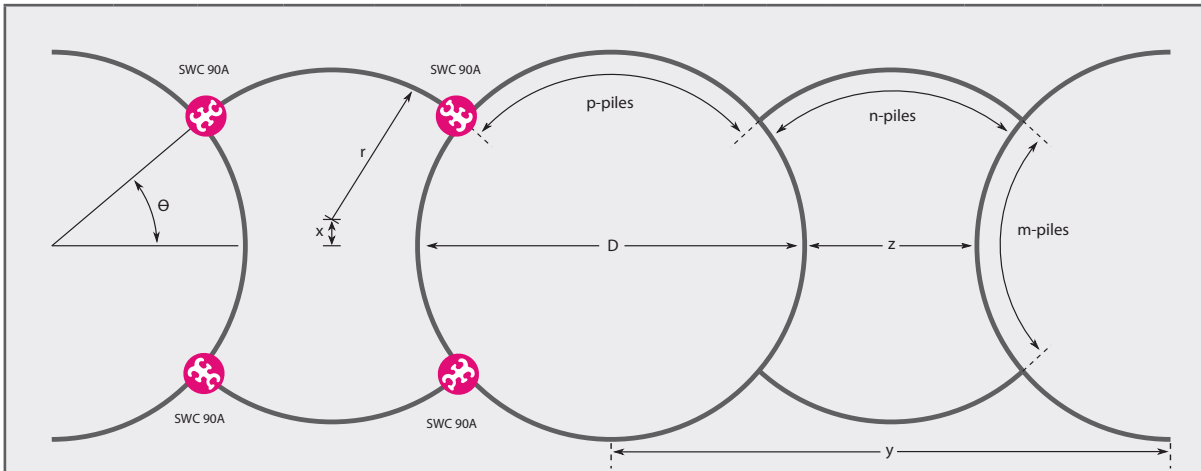

For SWC 90 A Connectors

Number of Piles/Cell	D ft	z ft	y ft	r ft	X ft	θ deg	Number of Piles			Area		Average Width ft
							m	n	p	within circle sq ft	between circles sq ft	
For θ deg at approximately 30°												
84	42.21	12.47	54.61	9.10	10.66	31.6	14	17	26	1399	566	35.9
96	48.48	13.72	62.19	10.15	12.23	31.4	16	19	30	1846	711	41.1
108	54.74	14.97	69.71	11.20	13.80	31.3	18	21	34	2354	873	46.3
120	61.01	16.22	77.23	12.24	15.36	31.1	20	23	38	2923	1051	51.5
132	67.28	19.56	86.83	14.33	16.93	31.0	22	27	42	3555	1406	57.1
144	73.55	20.81	94.35	15.37	18.50	31.0	24	29	46	4248	1631	62.3
156	79.81	22.06	101.87	16.42	20.06	30.9	26	31	50	5003	1871	67.5
For θ deg at approximately 45°												
44	21.20	7.53	28.73	9.72	0.68	45.3	10	9	10	353	197	19.2
52	25.38	6.31	31.69	9.73	2.15	45.2	12	9	12	506	210	22.6
60	29.56	5.09	34.64	9.73	3.62	45.2	14	9	14	686	218	26.1
76	37.91	5.59	43.51	11.83	5.09	45.1	18	11	18	1129	324	33.4
92	46.27	6.10	52.37	13.92	6.57	45.1	22	13	22	1681	450	40.7
100	50.45	4.88	55.33	13.92	8.04	45.1	24	13	24	1999	451	44.3
108	54.63	6.61	61.24	16.01	8.05	45.1	26	15	26	2344	596	48.0
116	58.80	5.39	64.19	16.01	9.52	45.1	28	15	28	2716	595	51.6

We have the right connector for all of your flat sheet pile projects.

Having trouble finding the best solution? Call us at (866) 666-7453 or email sales@pilepro.com and we will find the solution with you.

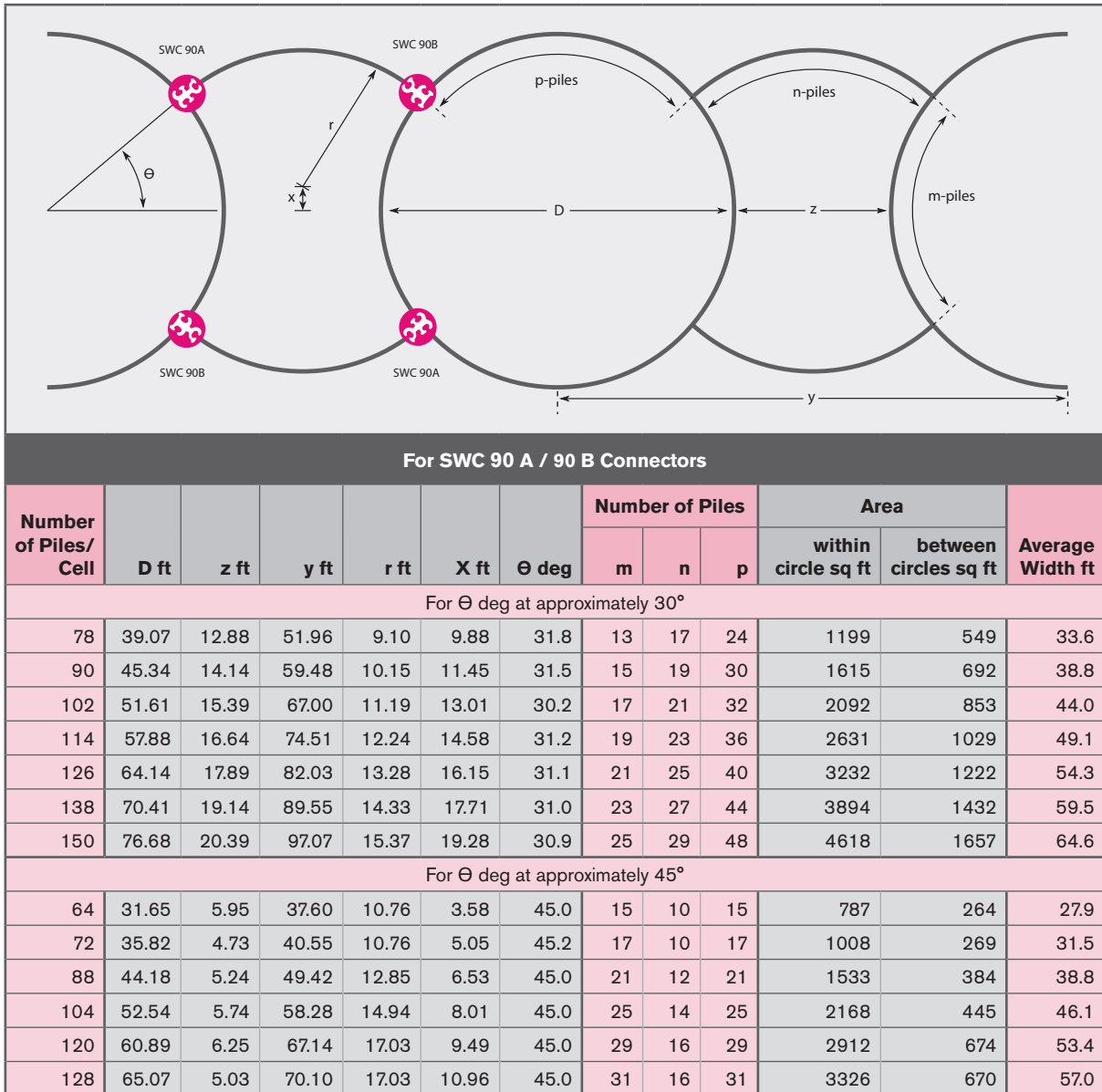

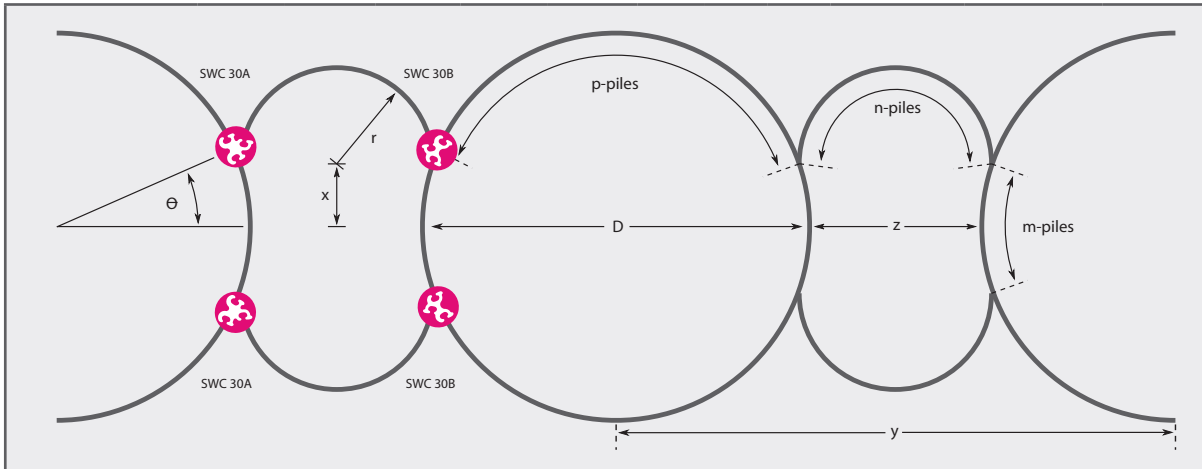

For SWC 30 A / 30 B Connectors

Number of Piles/Cell	D ft	z ft	y ft	r ft	X ft	θ deg	Number of Piles			Area		Average Width ft
							m	n	p	within circle sq ft	between circles sq ft	
68	33.73	5.42	39.15	10.82	4.28	45	16	10	16	894	269	29.7
84	42.09	5.92	48.02	12.91	5.76	45	20	12	20	1391	386	37.0
124	62.98	5.71	68.70	17.08	10.19	45	30	16	30	3116	677	55.2

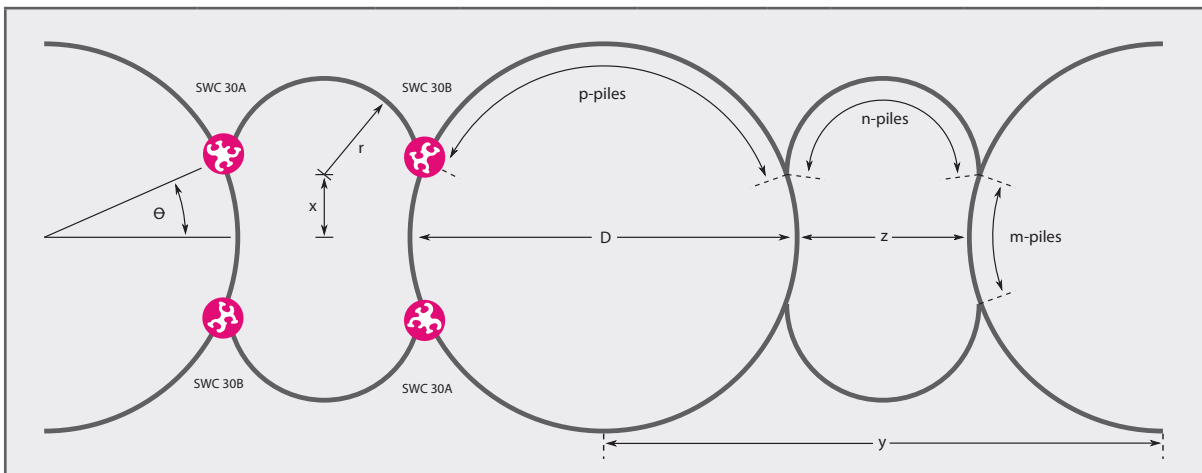

For SWC 30 A / 30 B Connectors

Number of Piles/Cell	D ft	z ft	y ft	r ft	X ft	θ deg	Number of Piles			Area		Average Width ft
							m	n	p	within circle sq ft	between circles sq ft	
48	23.29	6.84	30.13	9.67	1.45	45.2	11	9	11	426	203	20.9
56	27.47	5.62	33.09	9.68	2.92	45.2	13	9	13	593	213	24.3
80	40.00	4.91	44.91	11.77	5.87	45.1	19	11	19	1257	323	35.2
96	48.36	5.42	53.77	13.86	7.34	45.1	23	13	23	1837	448	42.5
112	56.72	5.92	62.64	15.95	8.82	45.1	27	15	27	2526	592	49.8

Flexibility

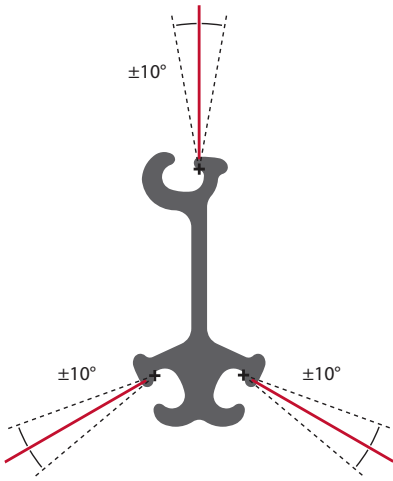

Dimensions

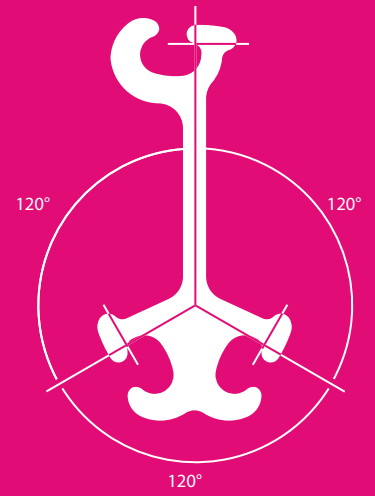
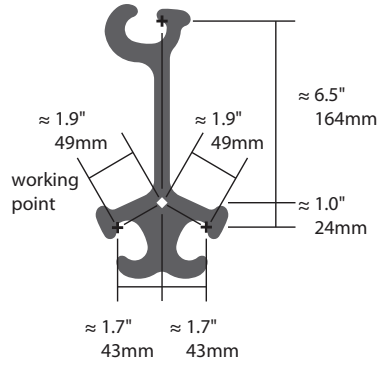

120 Flat Sheet

For 120° Y-corners

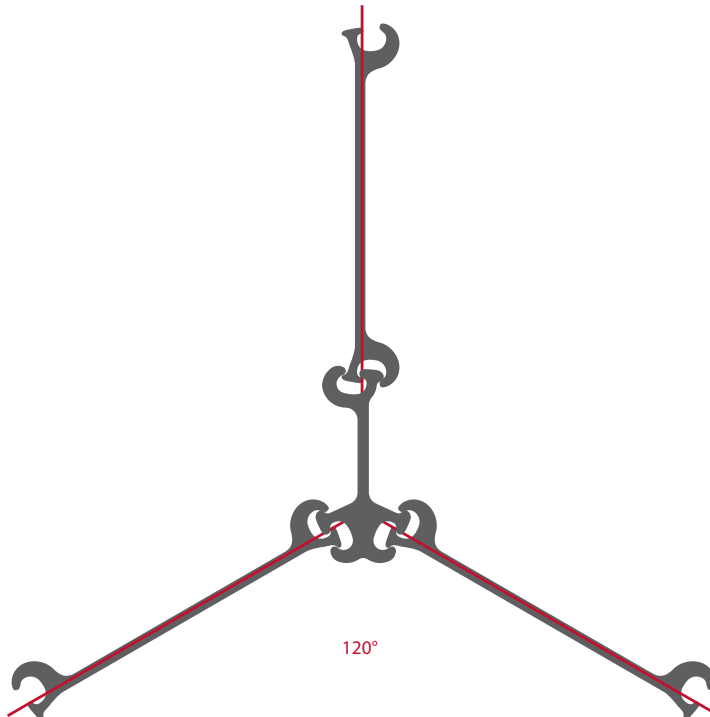

For additional details:
pilepro.com/120flat

WEIGHT:
~ 42.5 lb/ft
~ 63.3 kg/m

TYPICAL STEEL GRADES:
ASTM A572 Gr. 50/60
ASTM A690

Other steel grades available upon request.



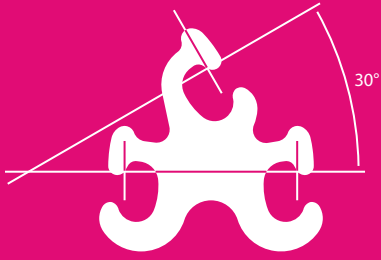

SWC 30 A

For 30° Y-corners in circular cells

Flexibility

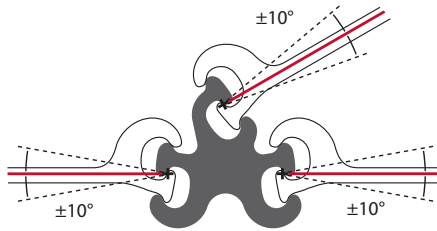

Dimensions

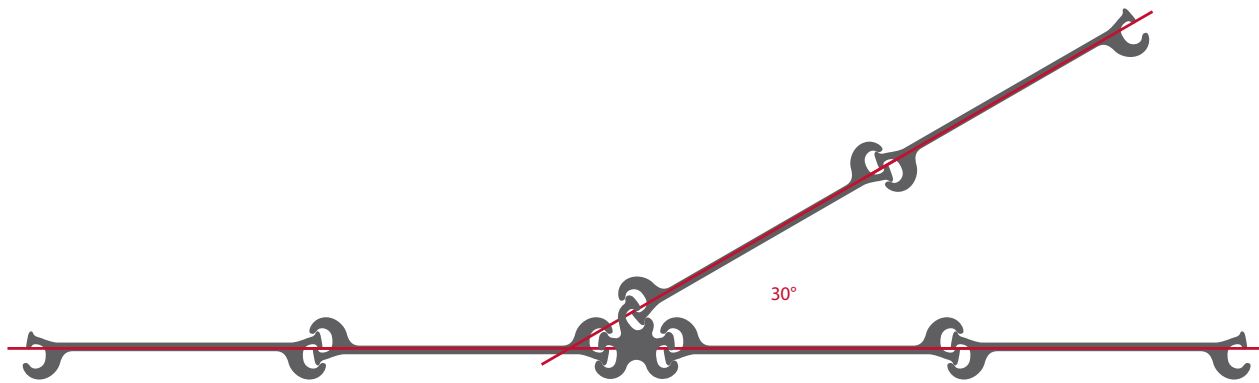
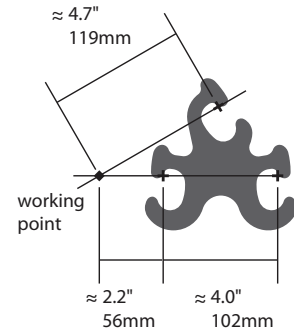

WEIGHT:

~ 38.0 lb/ft
~ 56.5 kg/m

TYPICAL STEEL GRADES:

ASTM A572 Gr. 50/60
ASTM A690
Other steel grades available upon request.



For additional details:
pilepro.com/swc30a

Flexibility

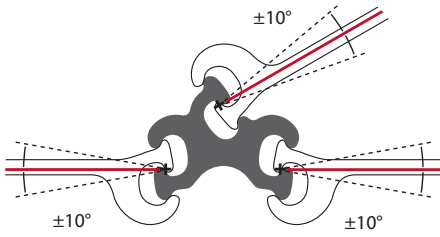

Dimensions

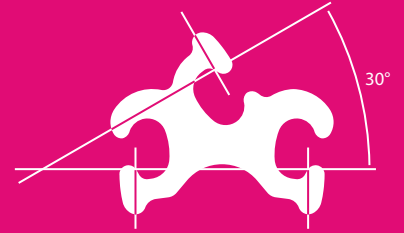
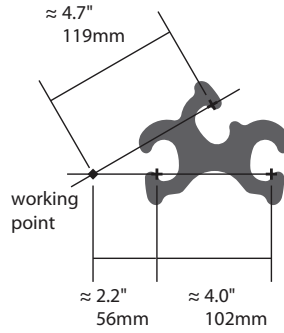

SWC 30 B

For 30° Y-corners in circular cells

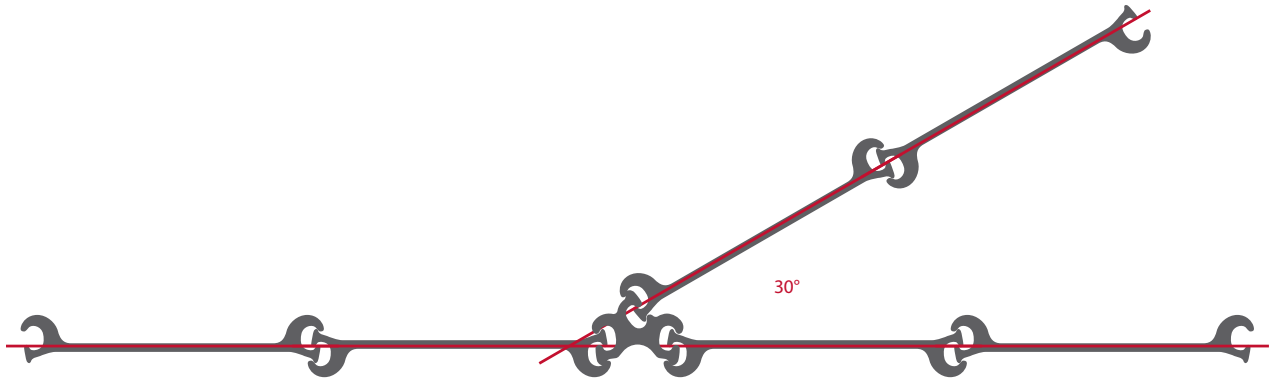

For additional details:
pilepro.com/swc30b

WEIGHT:
~ 28.9 lb/ft
~ 56.5 kg/m

TYPICAL STEEL GRADES:
ASTM A572 Gr. 50/60
ASTM A690

Other steel grades available upon request.



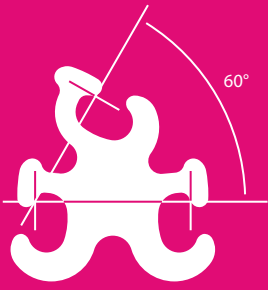

SWC 60 A

For 60° Y-corners in circular cells

Flexibility

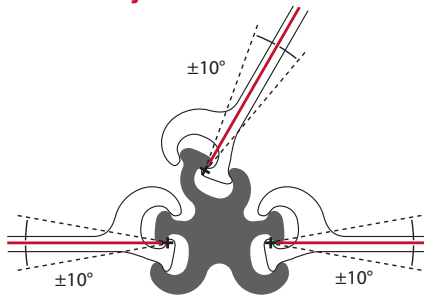

Dimensions

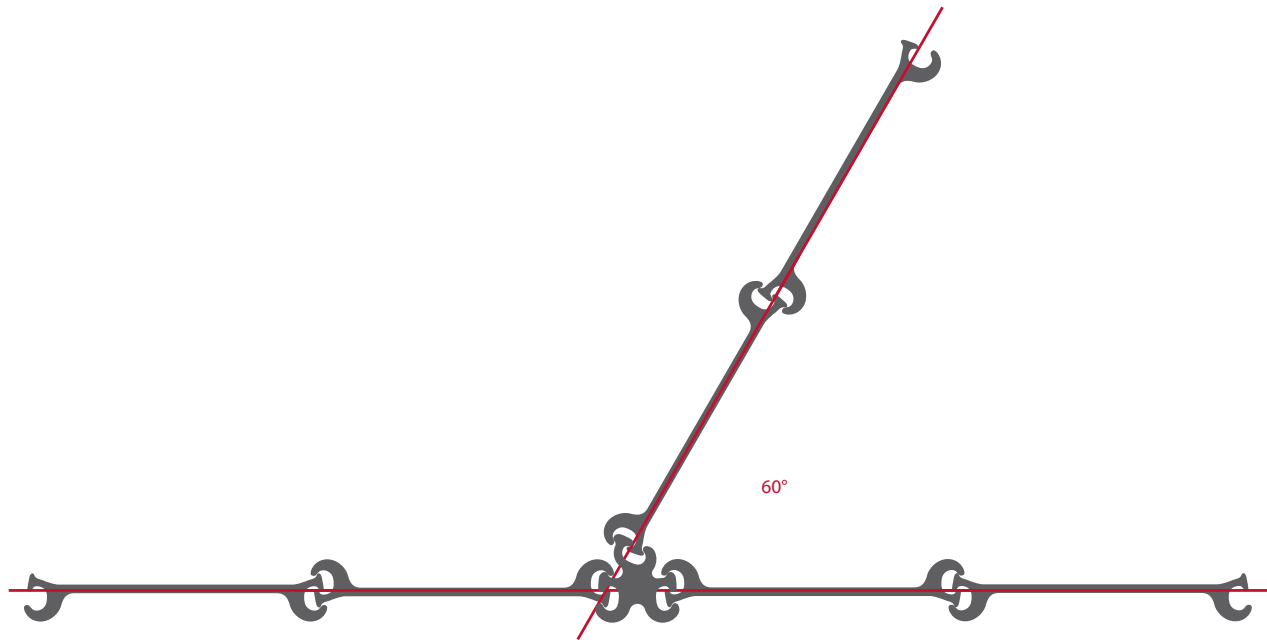
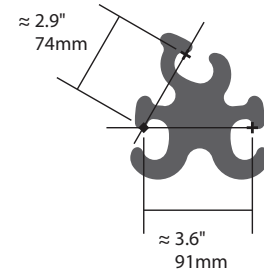

WEIGHT:

~ 41.2 lb/ft
~ 61.3 kg/m

TYPICAL STEEL GRADES:

ASTM A572 Gr. 50/60
ASTM A690
Other steel grades available upon request.



For additional details:
pilepro.com/swc60a

Flexibility

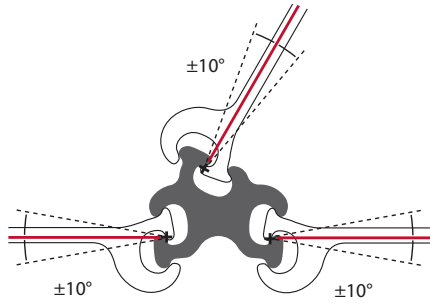

Dimensions

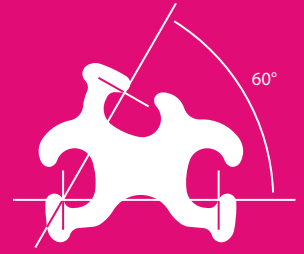
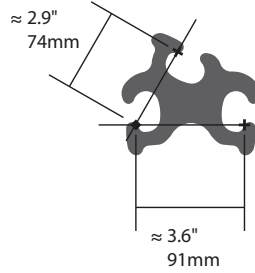

SWC 60 B

For 60° Y-corners in circular cells

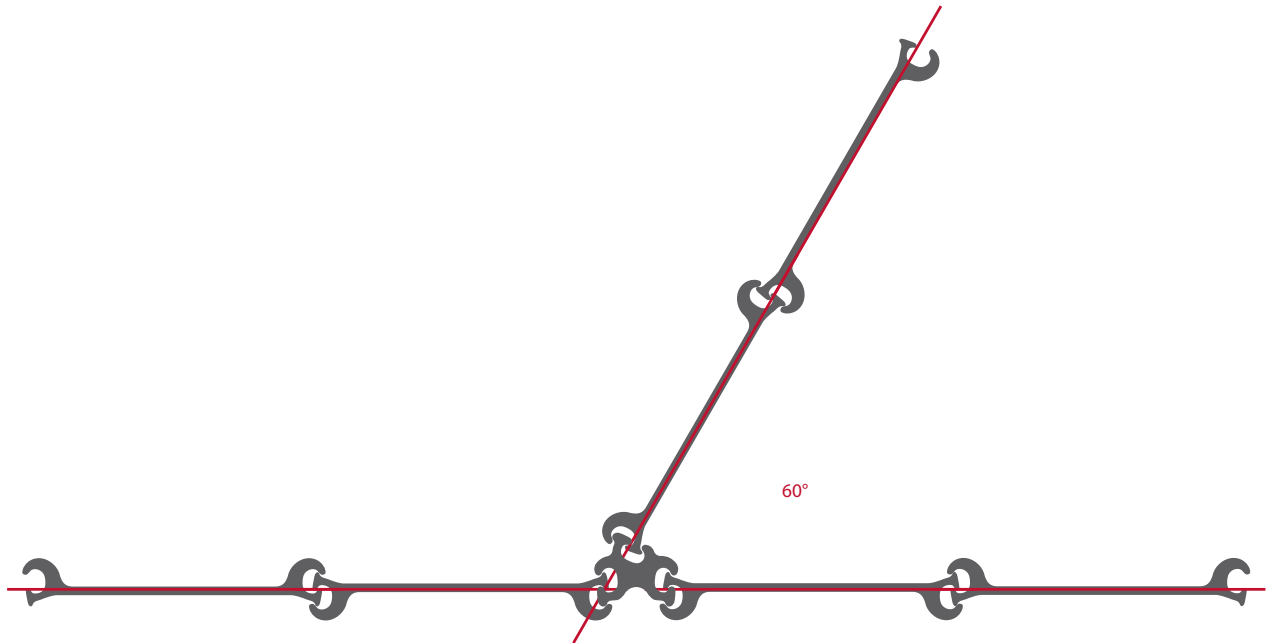

For additional details:
pilepro.com/swc60b

WEIGHT:
~ 33.5 lb/ft
~ 49.9 kg/m

TYPICAL STEEL GRADES:
ASTM A572 Gr. 50/60
ASTM A690

Other steel grades available upon request.



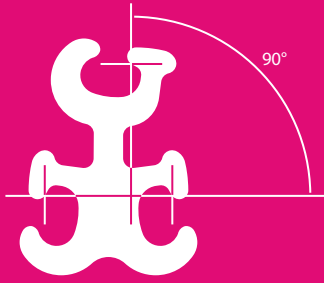

SWC 90 A

For 90° Y-corners in circular cells

Flexibility

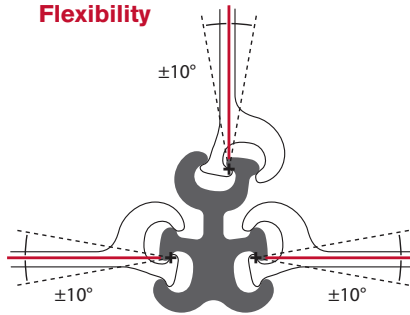

Dimensions

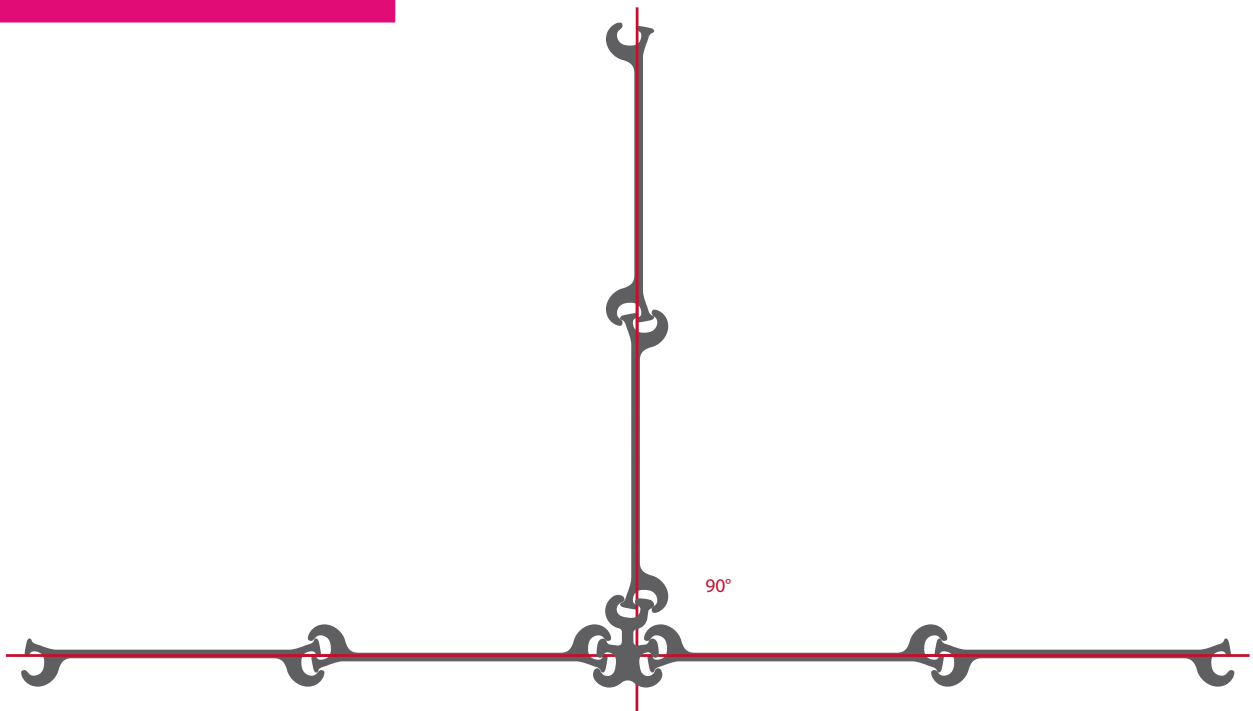
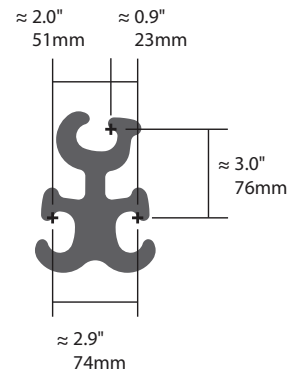

WEIGHT:

~ 35.8 lb/ft
~ 53.3 kg/m

TYPICAL STEEL GRADES:

ASTM A572 Gr. 50/60
ASTM A690
Other steel grades available upon request.



For additional details:
pilepro.com/swc90a

For Flat Sheet Pile

Flexibility

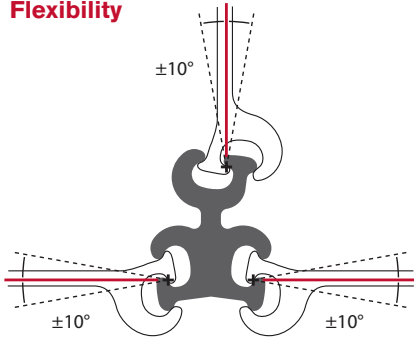

Dimensions

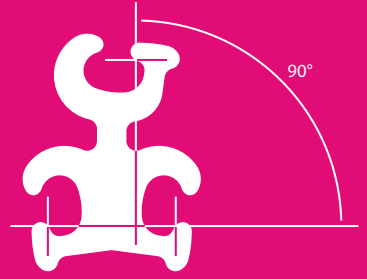
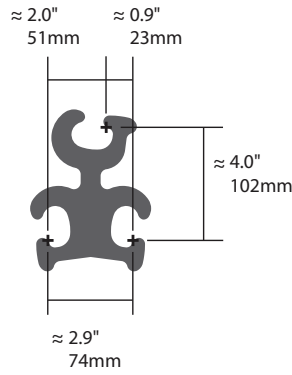

SWC 90 B

For 90° Y-corners in circular cells

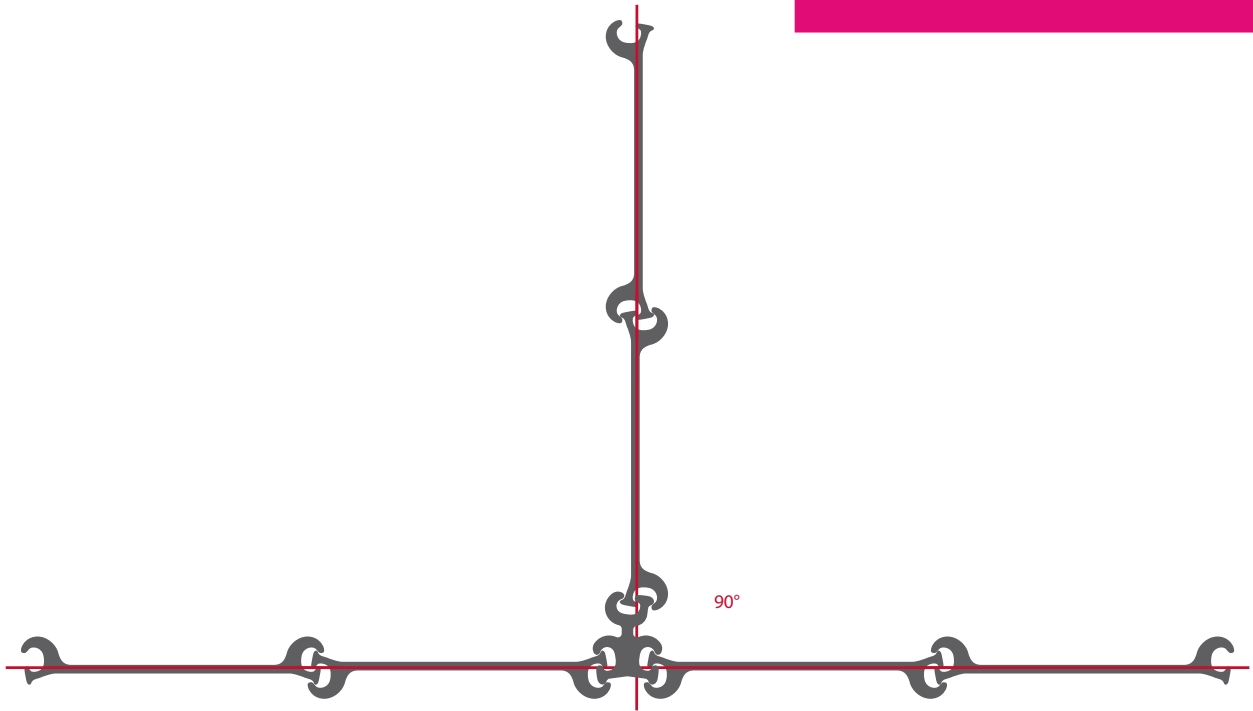

For additional details:
pilepro.com/swc90b

WEIGHT:
~ 35.8 lb/ft
~ 53.3 kg/m

TYPICAL STEEL GRADES:
ASTM A572 Gr. 50/60
ASTM A690

Other steel grades available upon request.



To place your order or for more information, call Evans Piling at (44) 114-243-1413.
Delivery of the most typical corner piles can be made to most UK destinations within 1 to 2 days.



SWC

For weld-on connections

Flexibility

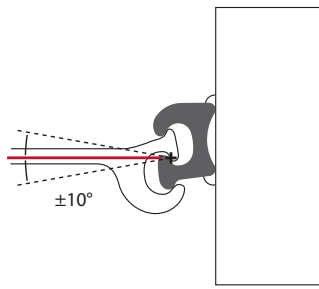

Dimensions

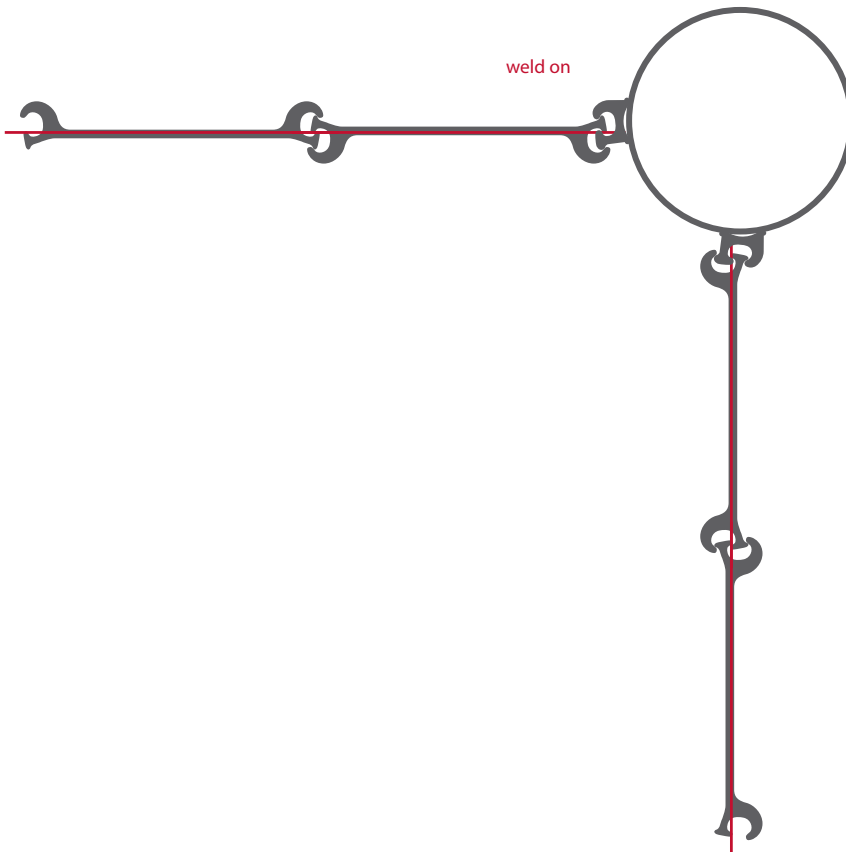

WEIGHT:
~ 12.4 lb/ft
~ 18.4 kg/m

TYPICAL STEEL GRADES:
ASTM A572 Gr. 50/60
ASTM A690
Other steel grades available upon request.



For additional details:
pilepro.com/swc





To place your order or for more information, call Evans Piling at (44) 114-243-1413.
Delivery of the most typical corner piles can be made to most UK destinations within 1 to 2 days.

Installation Guide

For all Flat Sheet PilePro connectors

1. Please review the proper interlocking examples that are listed.
2. Thread the connector into the interlock while the sheet pile is out of the ground.
3. Adjust the connector to the appropriate position.
4. Tack or spot-weld the connector in place. Typically, a ~250mm (~10") weld attaching the connector to the sheet pile to the top is sufficient.
5. Drive/extract the sheet pile (with the connector attached) as you would normally.

Interlocking Guide

Improper Use



For Cold Formed

PilePro produces cold formed connectors in three sizes (light, medium, and heavy) to cater to the broad range in gauge of cold form sheet piles available in the market place. The medium sizes are shown on the following pages. Information on the light and heavy sizes are available on request from PilePro.

Due to the wide range in thicknesses of cold formed sheet pile, it's not possible to display the interlock flexibility for all combinations. Please see pilepro.com for CAD downloads to get a precise flexibility estimate.

Angle rotation and interlock flexibility figures shown on following pages may vary subject to product rolling tolerances.

CFC 90	64
CF 90	65
CF Tee	66
Any-Z	67

BCF II/I	68
PCF II/I	70
CF Weld-on	72

System Overview

For Cold Formed Sheet Pile

Don't see the best solution?
Call us at
(866) 666-7453

CFC 90, p. 64
For 90° corners

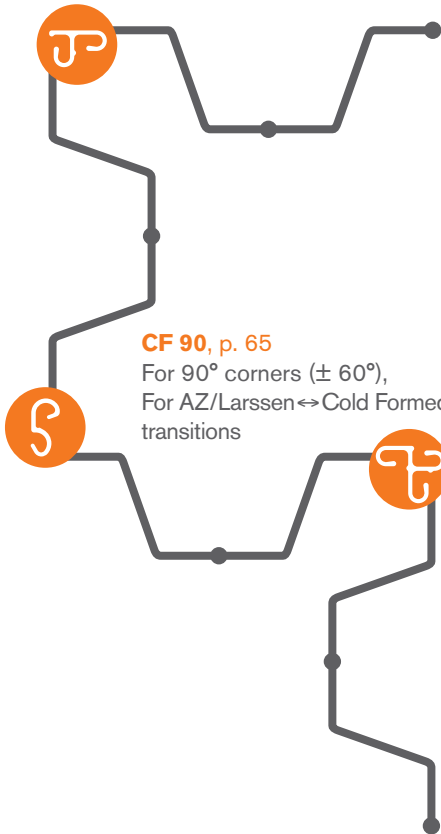

CF 90, p. 65
For 90° corners ($\pm 60^\circ$),
For AZ/Larssen \leftrightarrow Cold Formed
transitions

CF Tee, p. 66
For T-corners and 90° corners

Any-Z, p. 67
For 90° corners ($\pm 60^\circ$),
For CF/Cold formed \leftrightarrow PZ/PZC,
For CF/Cold formed \leftrightarrow AZ/Larssen
transitions

PilePro connectors are designed for compatibility with the great majority of cold formed piles available globally.

For sheets 1/2" thick and greater, we have large variations available by request.

We have the right connector for all of your cold formed sheet pile projects.

Having trouble finding the best solution? Call us at (866) 666-7453 or email sales@pilepro.com and we will find the solution with you.

Combined Sheet Piles

BCF II/I, p. 68

For combined sheet pile walls (wide flange beams)

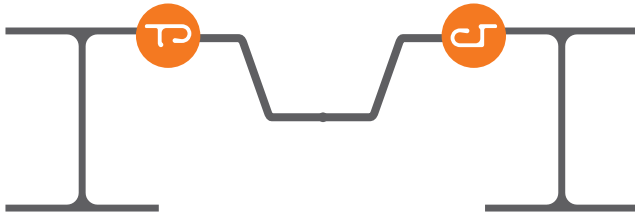

PCF II/I p. 70

For combined sheet pile walls (wide flange beams)

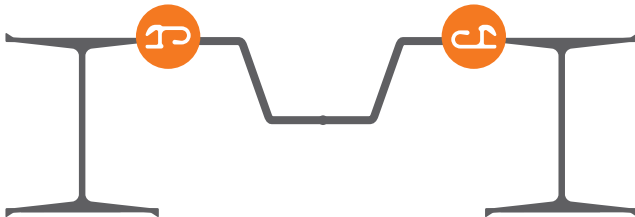

CF weld-on p. 72

For weld-on connections, combined sheet pile walls (pipes)



Transition Piles

CF 90, p. 65

For combined sheet pile walls (wide flange beams)



Any-Z, p. 67

For 90° corners ($\pm 60^\circ$), For CF/Cold formed \leftrightarrow PZ/PZC,
For CF/Cold-formed \leftrightarrow AZ/Larsen transitions

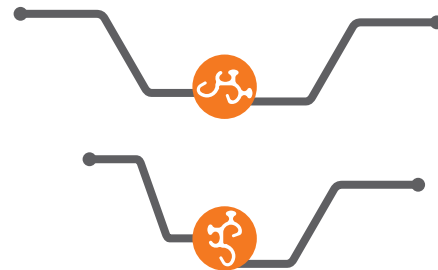

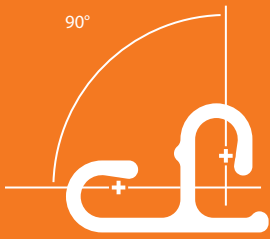

CFC 90

For 90° corners

Dimensions

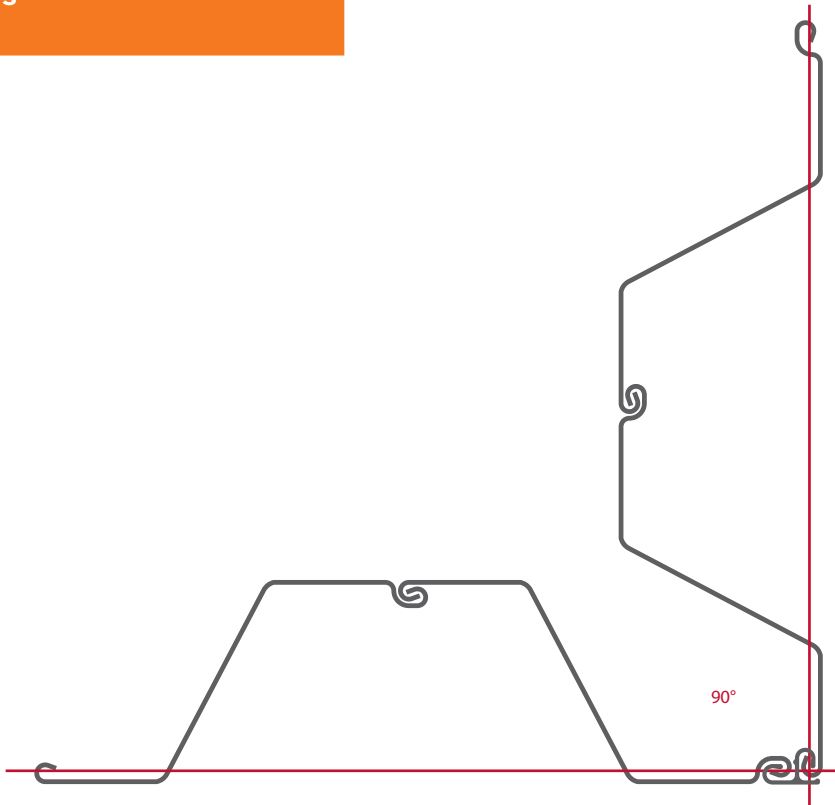
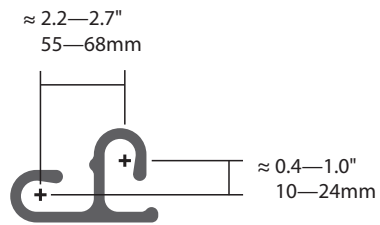

WEIGHT:
~ 12.0 lb/ft
~ 17.9 kg/m

TYPICAL STEEL GRADES:
ASTM A572 Gr. 50/60
ASTM A690
Other steel grades available upon request.



For additional details:
pilepro.com/cfc90

Dimensions

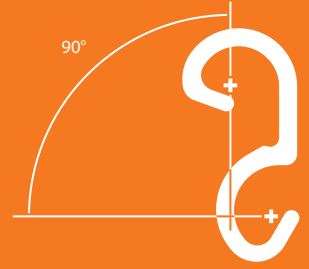
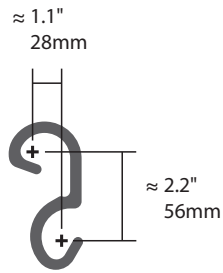

CF 90

For 90° corners ($\pm 60^\circ$),
For AZ/Larsen \leftrightarrow
Cold formed transitions

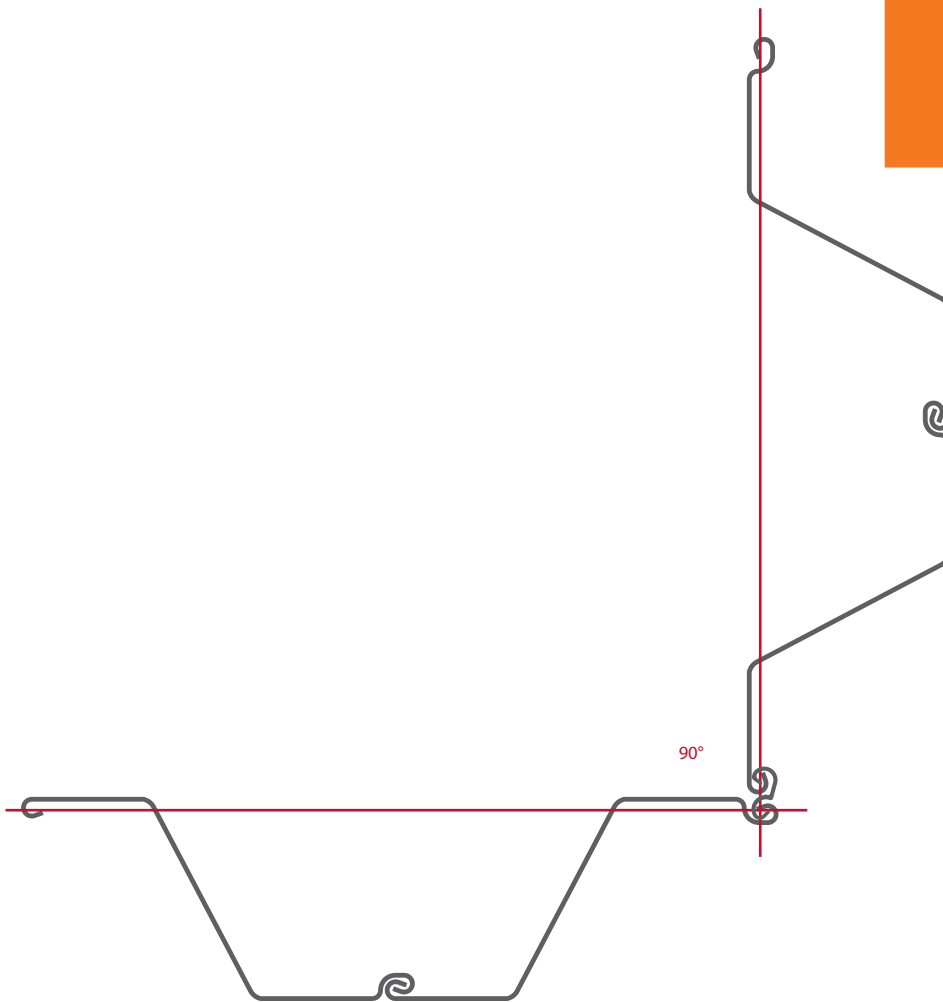

For additional details:
pilepro.com/cf90

WEIGHT:
~ 8.9 lb/ft
~ 13.2 kg/m

TYPICAL STEEL GRADES:
ASTM A572 Gr. 50/60
ASTM A690

Other steel grades available upon request.



Dimensions

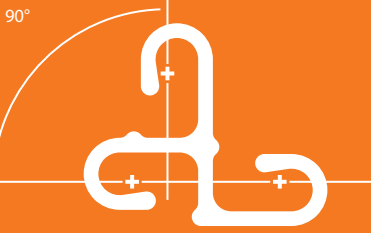
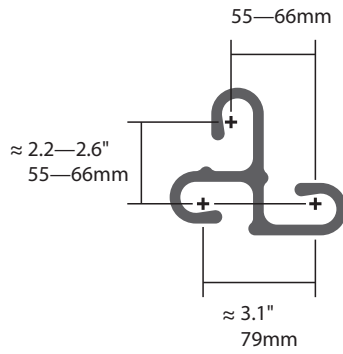

CF Tee

For T-corners and 90° corners

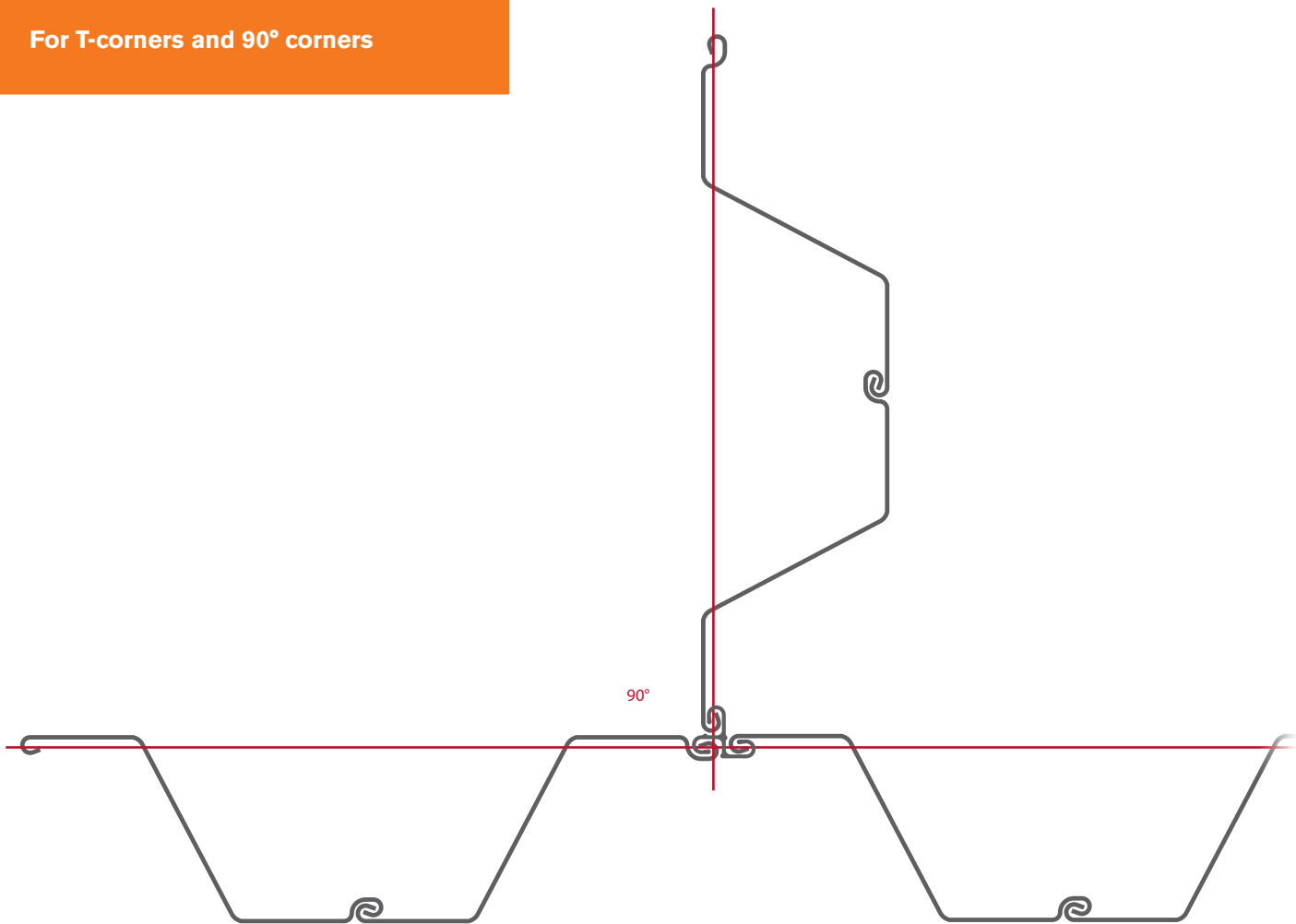

WEIGHT:
~14.6 lb/ft
~ 21.7 kg/m

TYPICAL STEEL GRADES:
ASTM A572 Gr. 50/60
ASTM A690
Other steel grades available upon request.



For additional details:
pilepro.com/cft



Dimensions

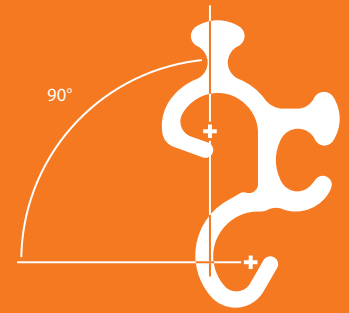
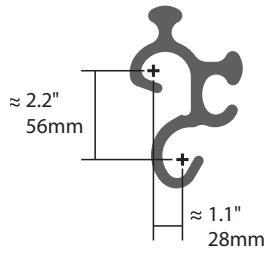

Any-Z

For 90° corners ($\pm 60^\circ$),
For CF/Cold formed \leftrightarrow PZ/PZC,
For CF/Cold formed \leftrightarrow AZ/Larsen
transitions

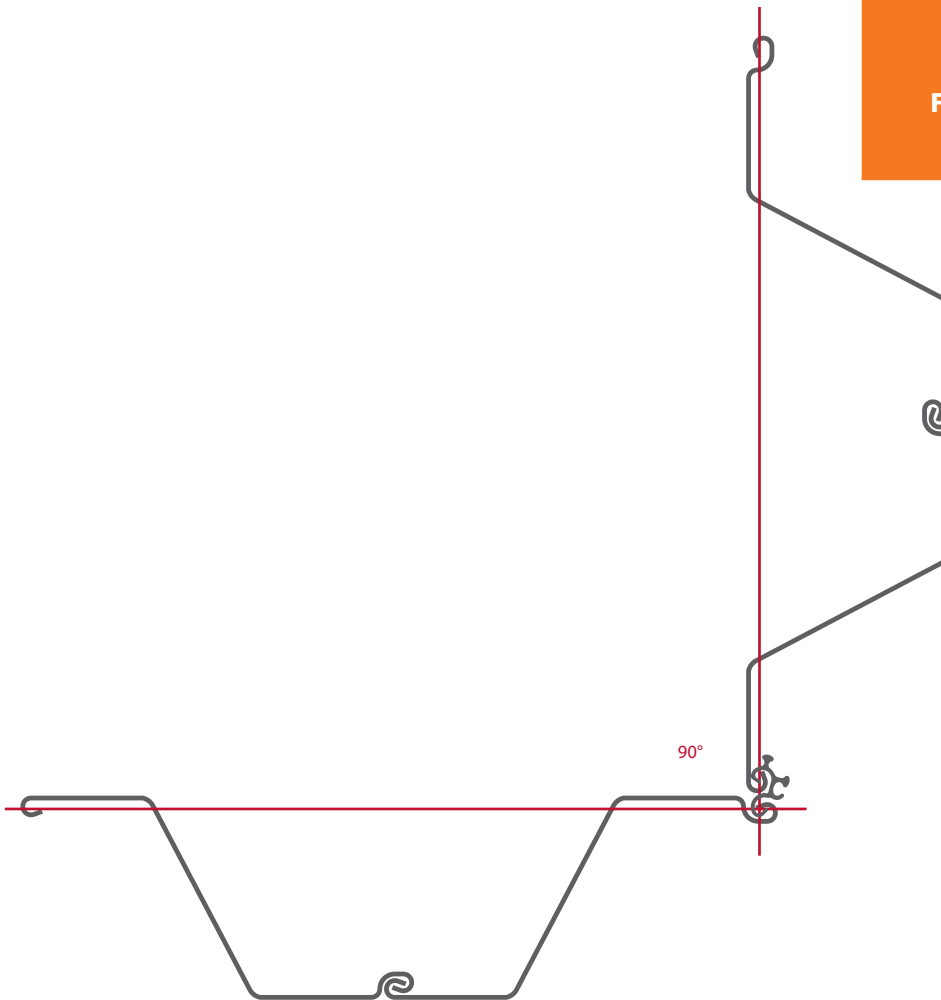

For additional details:
pilepro.com/anyz

WEIGHT:
~14.6 lb/ft
~ 21.7 kg/m

TYPICAL STEEL GRADES:
ASTM A572 Gr. 50/60
ASTM A690

Other steel grades available upon request.



Dimensions

≈ 1.7"
43mm

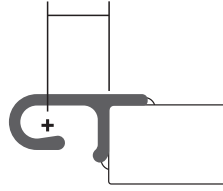

BCF II

For combined sheet pile walls
(wide flange beams)

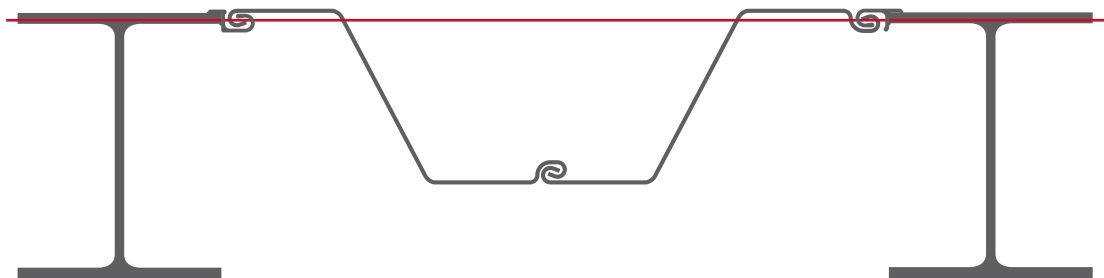

WEIGHT:
~10.3 lb/ft
~15.4 kg/m

TYPICAL STEEL GRADES:
ASTM A572 Gr. 50/60
ASTM A690
Other steel grades available upon request.



For additional details:
pilepro.com/bcf2

Dimensions

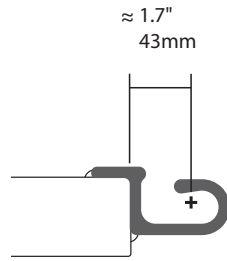

BCF I

For combined sheet pile walls
(wide flange beams)

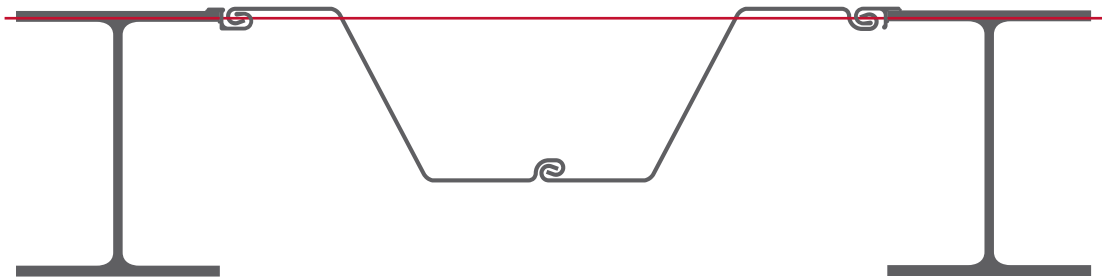

For additional details:
pilepro.com/bcf1

WEIGHT:
~10.3 lb/ft
~15.4 kg/m

TYPICAL STEEL GRADES:
ASTM A572 Gr. 50/60
ASTM A690
Other steel grades available upon request.



Dimensions

≈ 1.7"
44mm

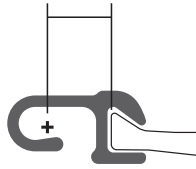

PCF II

For combined sheet pile walls
(wide flange beams)

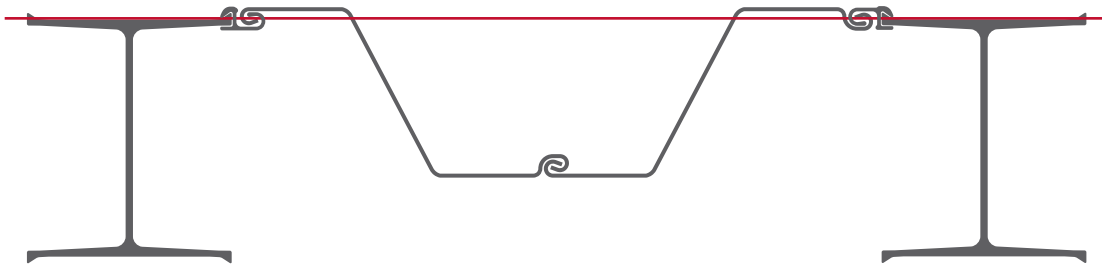

WEIGHT:

~ 10.1 lb/ft
~ 15.1 kg/m

TYPICAL STEEL GRADES:

ASTM A572 Gr. 50/60
ASTM A690
Other steel grades available upon request.



For additional details:
pilepro.com/pcf2

Dimensions

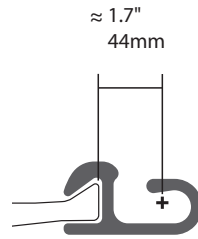

PCF I

For combined sheet pile walls
(wide flange beams)

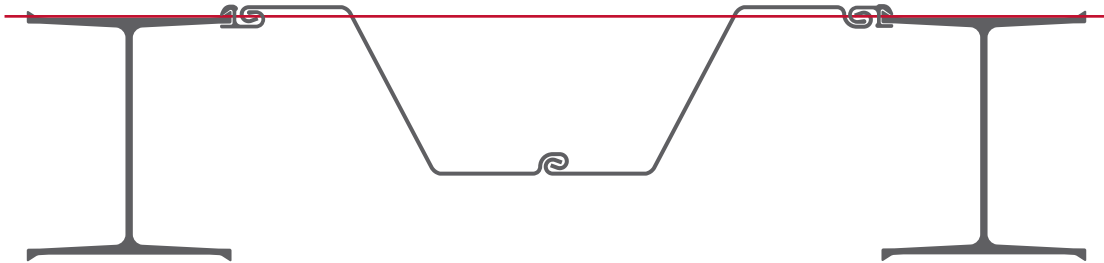

For additional details:
pilepro.com/pcf1

WEIGHT:
~ 10.1 lb/ft
~ 15.1 kg/m

TYPICAL STEEL GRADES:
ASTM A572 Gr. 50/60
ASTM A690

Other steel grades available upon request.



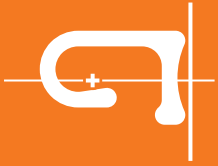

CF Weld-on

For weld-on connections,
combined sheet pile walls (pipes)

Flexibility



WEIGHT:

~ 7.5 lb/ft
~ 11.1 kg/m

TYPICAL STEEL GRADES:

ASTM A572 Gr. 50/60
ASTM A690
Other steel grades available upon request.



For additional details:
pilepro.com/cf

Installation Guide

CFC 90, CF 90, CF Tee, Any-Z

1. Please review the proper interlocking examples that are listed.
2. Thread the connector into the interlock while the sheet pile is out of the ground.
3. Adjust the connector to the appropriate position.
4. Tack or spot-weld the connector in place. Typically, a ~250mm (~10") weld attaching the connector to the sheet pile to the top is sufficient.
5. Drive/extract the sheet pile (with the connector attached) as you would normally.

BCF I/II

1. The beams are delivered with the connectors already attached.
2. First, install the king piles (beams) as you would in any combined sheet pile wall application.
3. Grasp the sheet piling and thread between the already installed beams.
4. All welding seams are a minimum ~6mm (~0.25").
5. Both sides have a continuous minimum tip and toe welding of ~500mm (~20").
6. Both sides are tack welded in the free length between tip and toe welding with ~200mm/m (~8"/yd). The distance from seam to seam is ~800mm (~31.5") or less.
7. In salt water, the water side is continuously welded on the whole pile length. Follow the instructions above for the reverse side of the pile, if it is not in contact with salt water.

PCF I/II

1. Install the Peiner beams first.
2. Lay the sheet piling horizontally and thread the connector into the interlock of the sheet piling, adjusting the connector to the appropriate position (please review the proper interlocking examples). This can be done at the mill, at a distributor's yard, or on the job site (go here: www.pilepro.com/thread).
3. Tack or spot-weld the connector in place. Typically, a ~250mm (~10") weld attaching the connector to the sheet pile to the top is sufficient.
4. Grasp the sheet pile (with connectors already attached) and thread between the already installed Peiner type beams.
5. Lower/drive the sheet piling to the level of the Peiner type beam.

CF

1. The pipes are delivered with the connectors already attached.
2. First, install the king piles (pipes) as you would in any combined sheet pile wall application.
3. Grasp the sheet piling and thread between the already installed pipe piles.
4. Increase flexibility in the middle interlocks of the sheet piles, combined with the swing of the connectors, to enable easier threading of the intermediate sheet piling.
5. All welding seams are a minimum ~6mm (~0.25").
6. Both sides have a continuous minimum tip and toe welding of ~500mm (~20").
7. Both sides are tack welded in the free length between tip and toe welding with 200mm/m (8"/yd). The distance from seam to seam is ~800mm (~31.5") or less.
8. In salt water, the water side is continuously welded on the whole pile length. Follow the instructions above for the reverse side of the pile, if it is not in contact with salt water.

Interlocking Guide

Proper Use



Improper Use





O-Pile is the brand name for the high capacity Pipe to Pipe wall concept using the WOM/WOF-XL or WOM/WOF-XXL connectors. O-Pile is a franchise opportunity from PilePro to interested pipe producers or sheet piling distributors interested in becoming a PilePro partner company and having exclusive regional representation for the Pipe to Pipe wall system.

PilePro has O-Pile partners in many parts of the world. If you are interested in the opportunity to have access to this highly competitive, efficient, and high capacity alternative to conventional retaining wall systems, then please contact us at info@o-pile.com

For Pipe Sheet Pile®

The WOM/WOF-XL and XXL connectors provide unique ability to connect pipe to pipe in a number of configurations that give varying levels of pipe spacing. The WOM/WOF-XL gives an optimum spacing for installation in the majority of pipe to pipe solutions. The WOM/WOF-XXL gives an extended spacing to target design loading requirement or reduce number of piles where driving conditions permit.

Angle rotation and interlock flexibility figures shown on following pages may vary subject to product rolling tolerances.

WOM-XL/WOF-XL80

WOM-XXL/WOF-XXL82

WOM-S/WOF-S84



Unmatched Efficiency

The Power of the Circle

Pipe Sheet Pile Systems have unmatched efficiency. King pile systems using products like HZM or PSp increase in weight linearly as strength is increased, mainly because there is little change in panel width across the product range. However, a pipe-to-pipe system of a given wall thickness has almost negligible weight increase as pipe diameter increases; but strength does increase, leading to a power-curve efficiency ratio as seen in this graph.

We have selected a few comparison systems, called out on the graph: each shows a typical combined-wall system with typical king piles and the much more efficient Pipe Sheet Pile system utilizing PilePro connectors.

Strength vs Weight

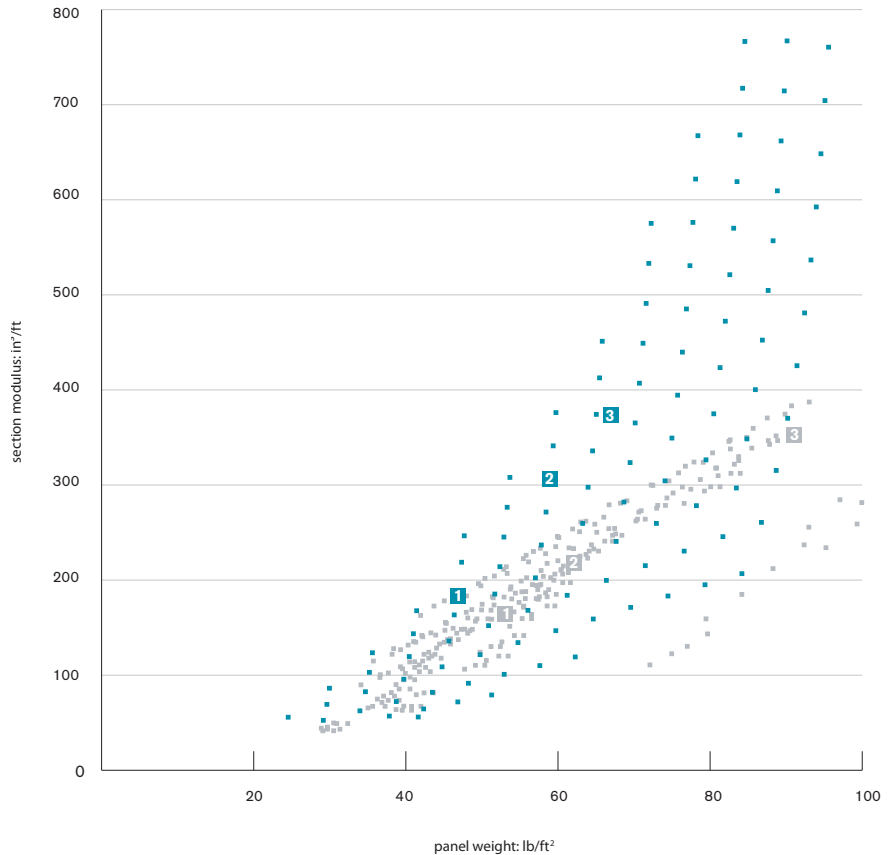

With the low cost and wide availability of steel pipes and PilePro WOM/F-XL connectors, we have a truly unmatched solution.

Comparison No. 1	
Pipe Sheet Pile	Typical system
O 103 48" x .5"	HZ 880M C-24 + AZ 14-770
191 in ³ /ft	167 in ³ /ft
47 lb/ft ²	54 lb/ft ²

Comparison No. 2	
Pipe Sheet Pile	Typical system
O 165 60" x .625"	PSp 1117 (1023) + PZ612
306 in ³ /ft	211 in ³ /ft
59 lb/ft ²	62 lb/ft ²

Comparison No. 3	
Pipe Sheet Pile	Typical system
O 201 66" x .6875"	HZ 1180M D-24 + AZ 26-700
374 in ³ /ft	356 in ³ /ft
65 lb/ft ²	91 lb/ft ²

Case Study: Hatem Bridge

WOM/WOF-XL connectors were used to form high capacity pipe to pipe cofferdams at the Hatem Memorial Bridge foundation strengthening project in North-East Maryland.

The high bending strength and stiffness of a continuous pipe-to-pipe wall was preferred over other options to resist over 90 feet of water pressure and form a safe excavation for the contractor.

WOM/WOF-XL connectors provided the highest degree of tension and bending strength available to secure the pipe-to-pipe connection and ensure pile integrity after hard driving.

The pipe-to-pipe solution is quickly gaining recognition as the most efficient high capacity solution for retaining structures in the marketplace today. The growing use of pipe-to-pipe solutions has been made feasible by the introduction of the WOM/WOF-XL connector. Previous methods of connecting pipes were complex, slow and difficult to get right. WOM/F-XL gives the contractor for the first time a high capacity connection that's easy to install.

Cofferdam completed with pipe to pipe piles using WOM/WOF-XL.



View of pier cofferdams at varying stages of construction.

This panel was assembled and moved into position under the bridge due to limited headroom.

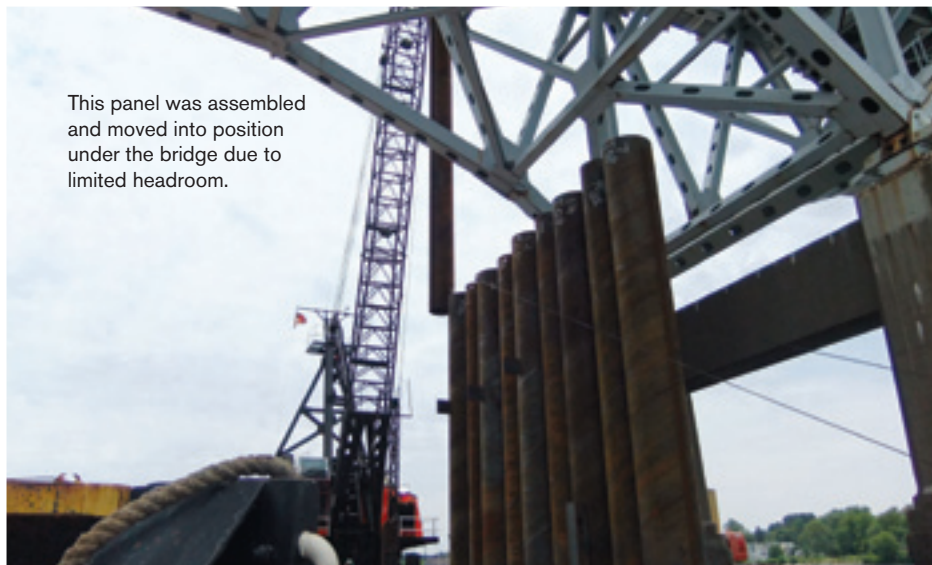

System Overview

For Pipe Sheet Pile

WOM-XL / WOF-XL, p. 80

High capacity Pipe Sheet Pile system

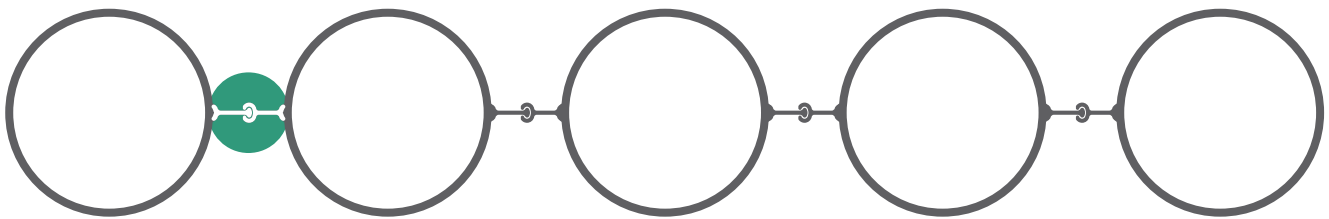

WOM-XXL / WOF-XXL, p. 82

Extended Pipe Sheet Pile system

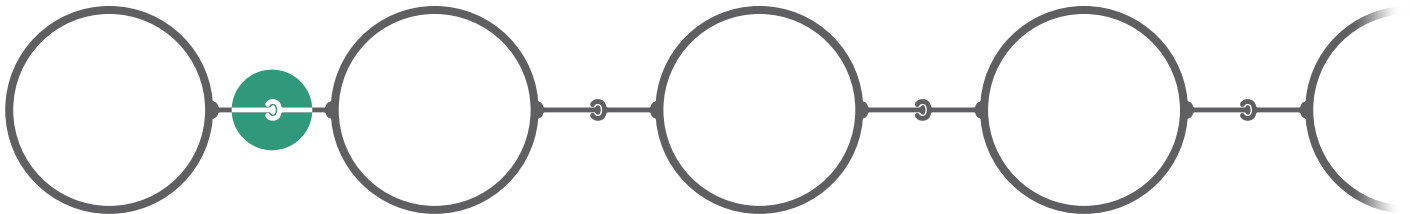

WOM-S / WOF-S, p. 84

High capacity Pipe Sheet Pile system for difficult driving conditions

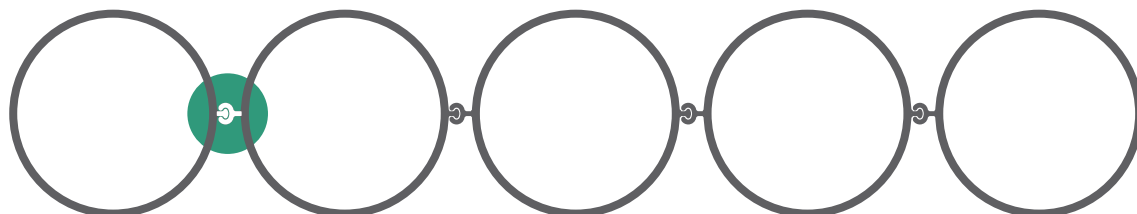

Having trouble finding the best solution? Call us at (866) 666-7453 or email sales@pilepro.com and we will find the solution with you.

Combined Wall Systems (see p.27)

WOM-XL / WOF-XL, p.42

Increased combined wall spacing, or to get more flexibility in design

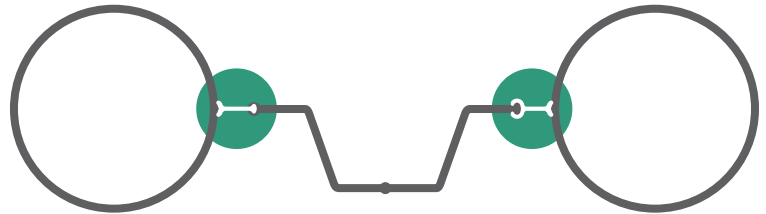

WOM-XXL / WOF-XXL 44

Extended combined wall system

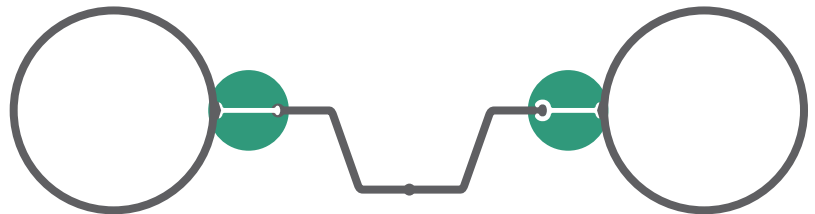

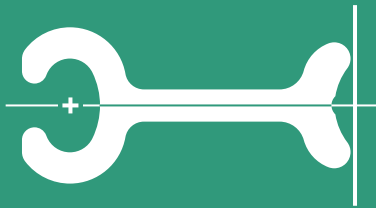

WOF-XL

For Pipe + Pipe,
For combined walls (pipes)

Flexibility

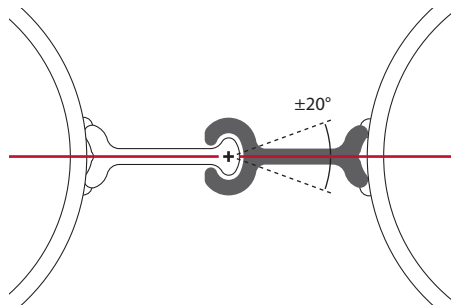

Dimensions

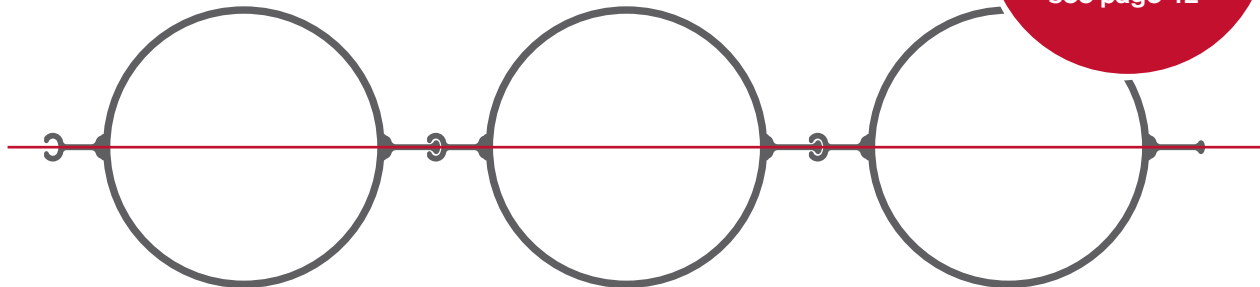
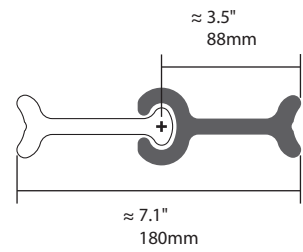

Pipe sheet pile walls

For Combined
Walls Systems
using WOM/F-XL,
see page 42

WEIGHT:
~ 12.0 lb/ft
~ 17.8 kg/m

TYPICAL STEEL GRADES:
ASTM A572 Gr. 50/60
ASTM A690
Other steel grades available upon request.



For additional details:
pilepro.com/wof-xl



For Pipe Sheet Pile

Flexibility

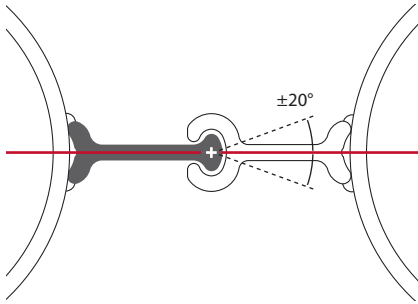

Dimensions

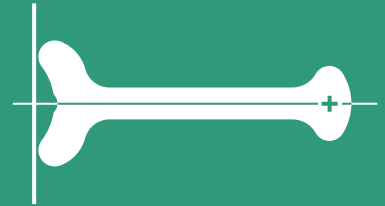
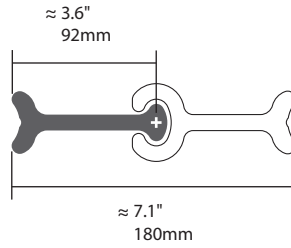

WOM-XL

For Pipe + Pipe,
For combined walls (pipes)

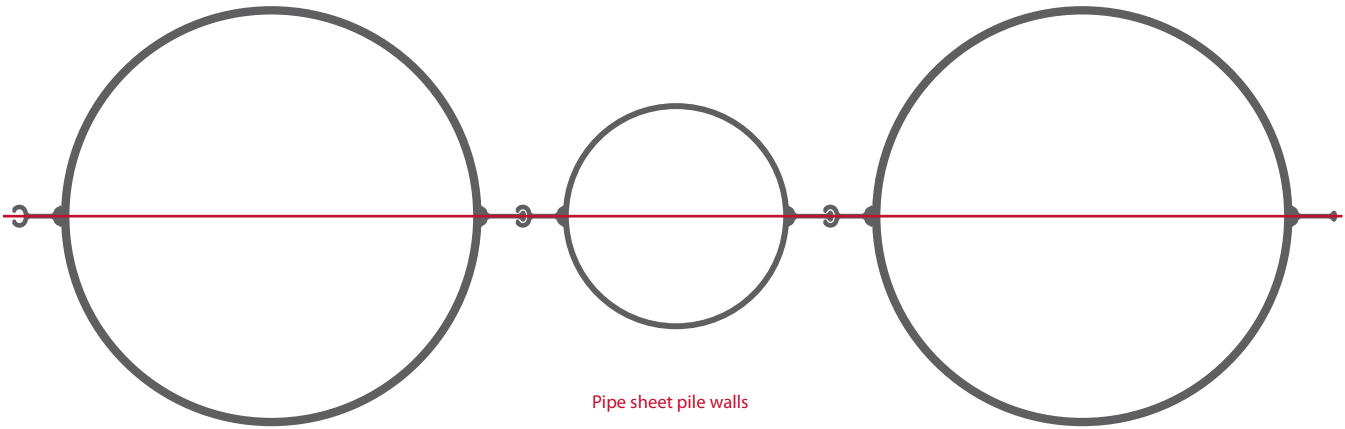

Pipe sheet pile walls



For additional details:
pilepro.com/wom-xl

WEIGHT:
~ 8.5 lb/ft
~ 12.7 kg/m

TYPICAL STEEL GRADES:
ASTM A572 Gr. 50/60
ASTM A690

Other steel grades available upon request.



To place your order or for more information, call Evans Piling at (44) 114-243-1413.
Delivery of the most typical corner piles can be made to most UK destinations within 1 to 2 days.

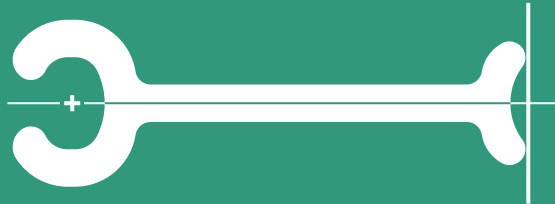

WOF-XXL

For Pipe + Pipe,
For combined walls (pipes)

Flexibility

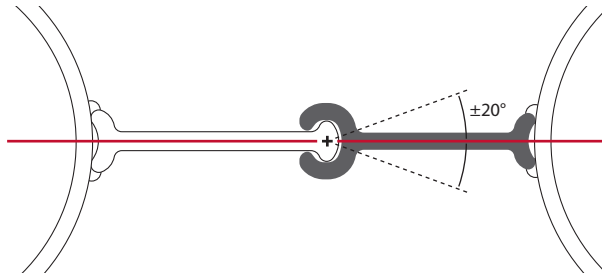

Dimensions

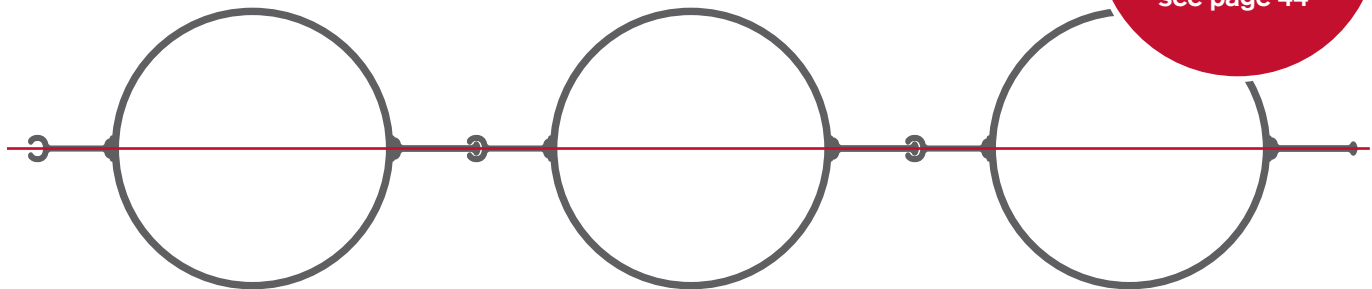
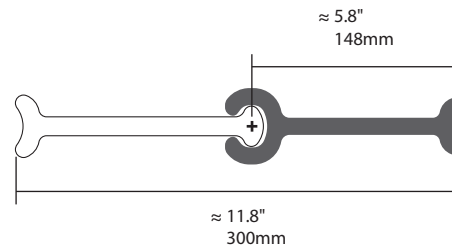

Pipe sheet pile walls

For Combined
Walls Systems
using WOM/F-XXL,
see page 44

WEIGHT:

~ 15.8 lb/ft
~ 23.5 kg/m

TYPICAL STEEL GRADES:

ASTM A572 Gr. 50/60
ASTM A690
Other steel grades available upon request.



For additional details:
pilepro.com/wof-xxl

Flexibility

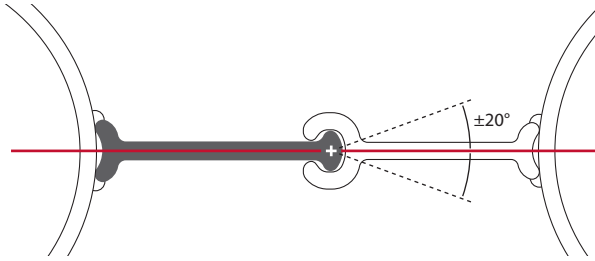

Dimensions

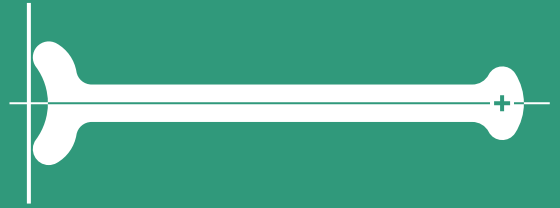
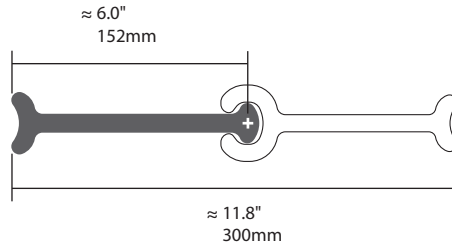

WOM-XXL

For Pipe + Pipe,
For combined walls (pipes)

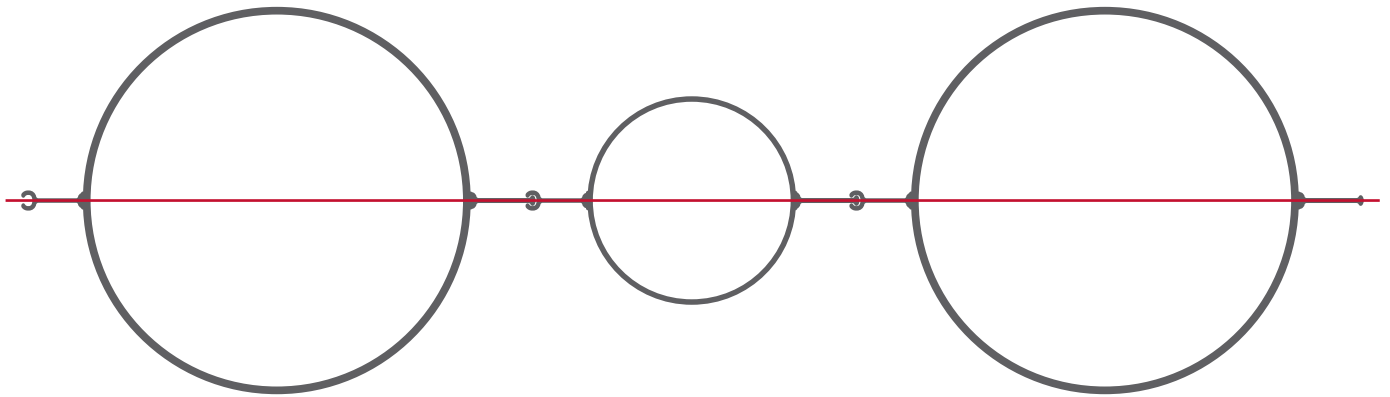

Pipe sheet pile walls



For additional details:
pilepro.com/wom-xxl

WEIGHT:
~ 12.4 lb/ft
~ 18.5 kg/m

TYPICAL STEEL GRADES:
ASTM A572 Gr. 50/60
ASTM A690

Other steel grades available upon request.



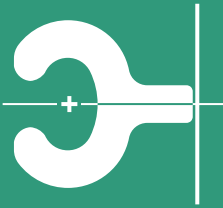

WOF-S

For Pipe + Pipe in difficult driving conditions

Flexibility

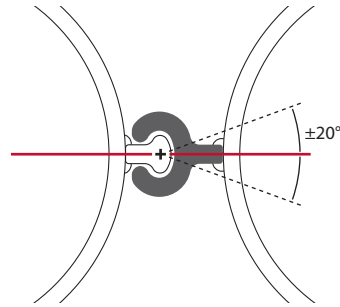

Dimensions

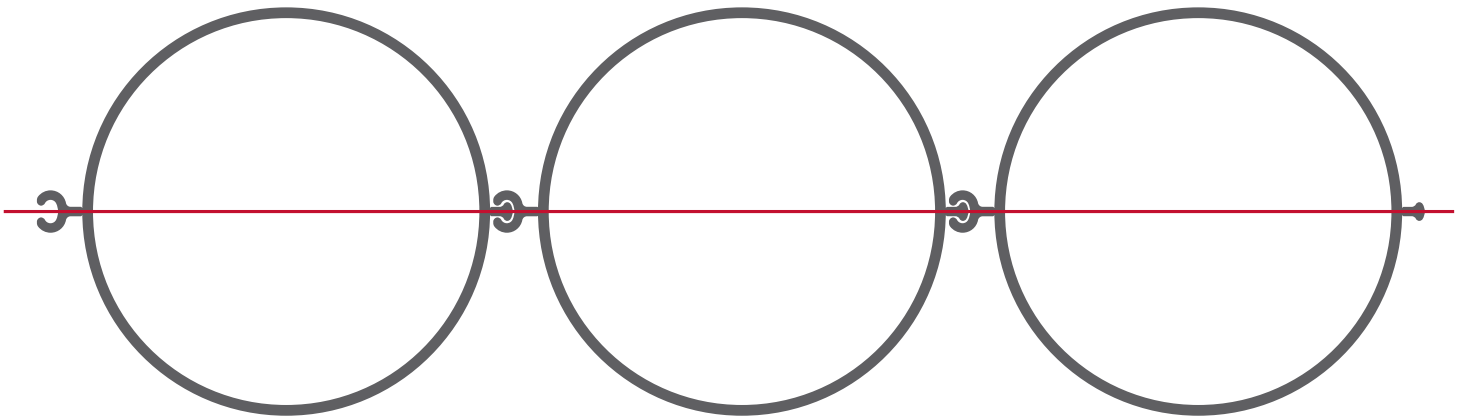
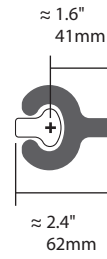

Pipe sheet pile walls

WEIGHT:

~ 7.5 lb/ft
~ 11.1 kg/m

TYPICAL STEEL GRADES:

ASTM A572 Gr. 50/60
ASTM A690
Other steel grades available upon request.



For additional details:
pilepro.com/wof-s

Flexibility

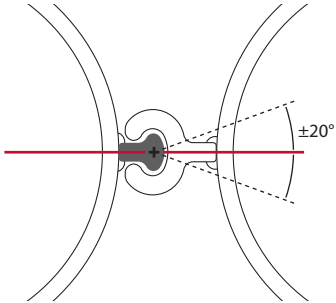

Dimensions

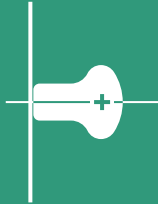
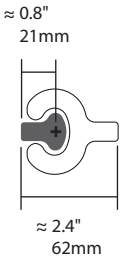

WOM-S

For Pipe + Pipe in difficult driving conditions

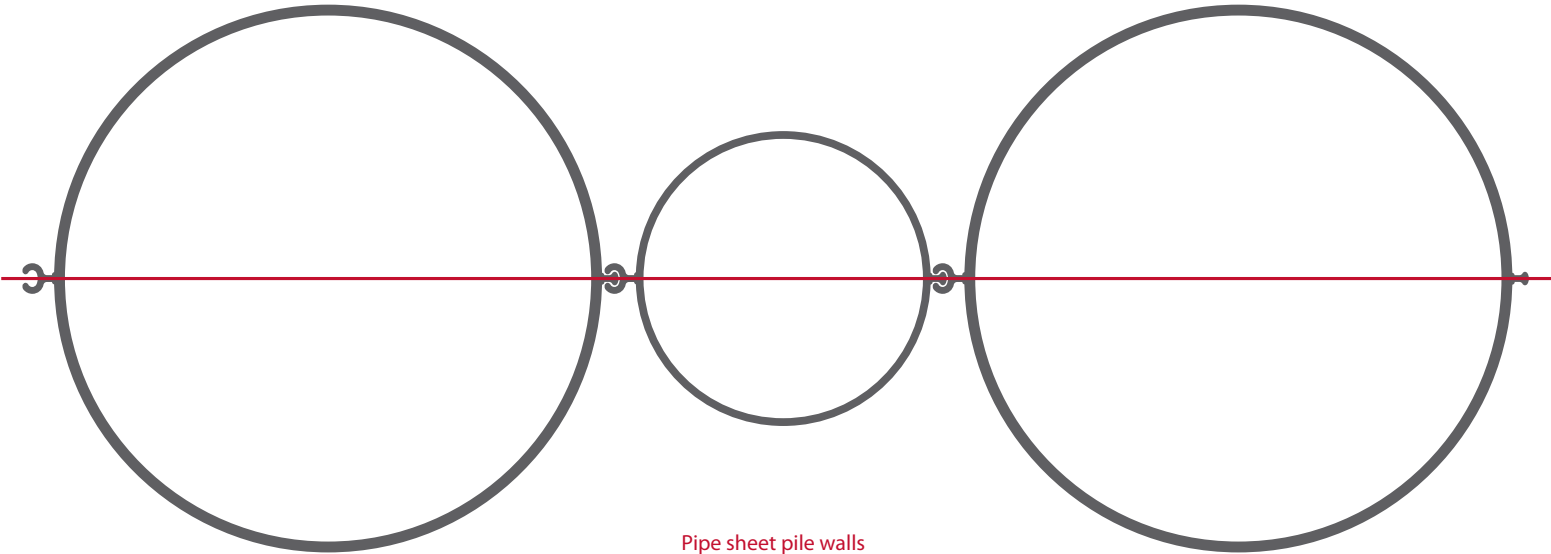

Pipe sheet pile walls



For additional details: pilepro.com/wom-s

WEIGHT:
~ 2.4 lb/ft
~ 3.6 kg/m

TYPICAL STEEL GRADES:
ASTM A572 Gr. 50/60
ASTM A690

Other steel grades available upon request.

Installation Guide

For all Pipe Sheet Pile connectors

1. Please review the proper interlocking examples that are listed.
2. Thread the connector into the interlock while the sheet pile is out of the ground.
3. Adjust the connector to the appropriate position.
4. Tack or spot-weld the connector in place. Typically, a ~250mm (~10") weld attaching the connector to the sheet pile to the top is sufficient.
5. Drive/extract the sheet pile (with the connector attached) as you would normally.

Interlocking Guide

Proper Use



Improper Use

